

**Hornos Mixtos
Fours Mixtes
Combi Ovens
HeiBluftdämpfer
Forno Misti**

Modelos:

HMM-20/11

HME-20/11

HMP-20/11

VECM-20/11

VECE-20/11

VECP-20/11

HMM-20/11 UL

THCV-20/11

THCV-20/11P



MFHMM-20/11

Noviembre 2003 November

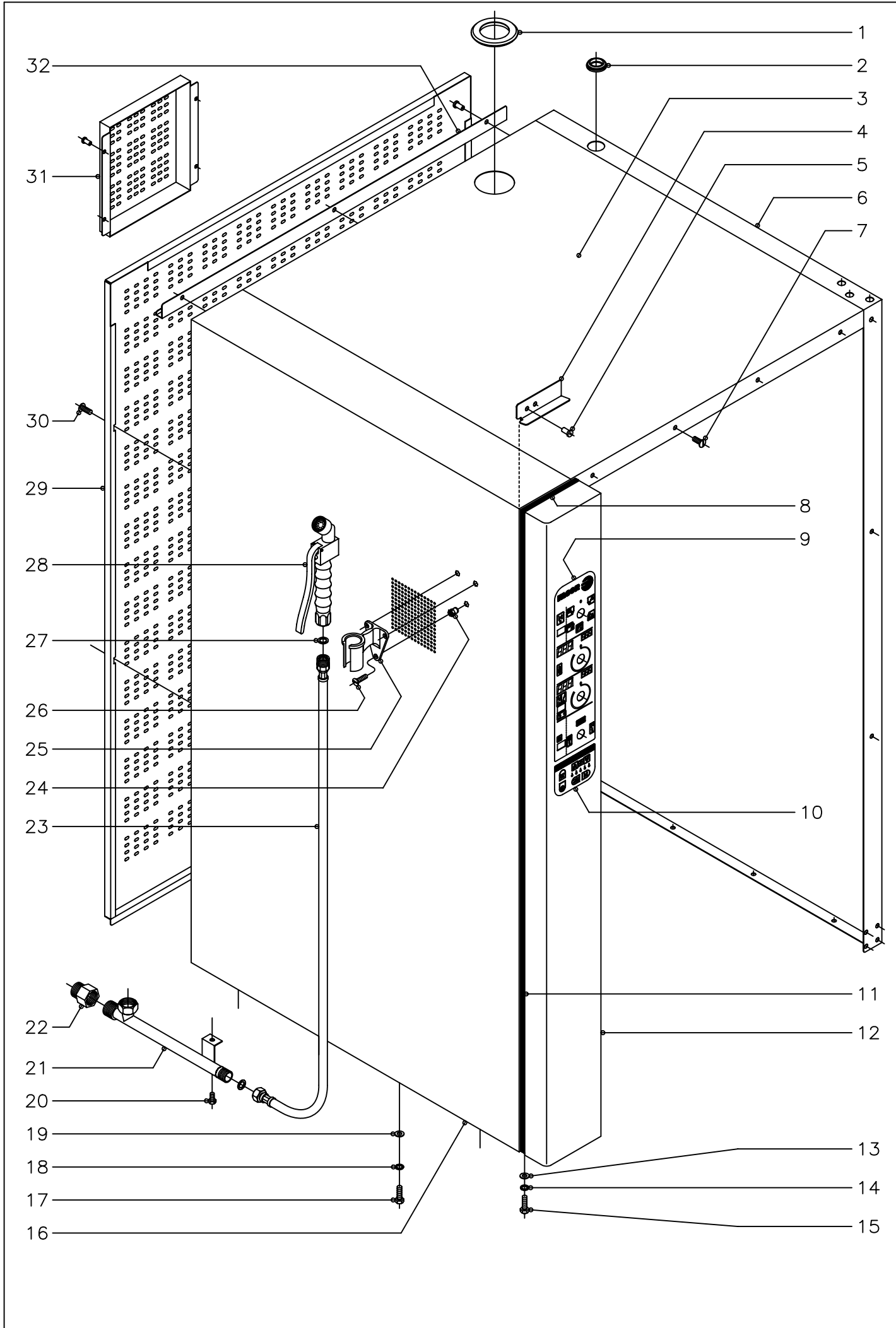

Fagor Industrial



N plano C-1459	Firma 	Fecha 11-2003	Aparato MUEBLE HORNOS HMM, HME, HMP-20/11	Lamina 1	Fagor Industrial S.Coop. FAGOR  Onate
-------------------	--	------------------	---	-------------	--

MOD.	HORNOS : HMM, HME, HMP-20/11	ZONA	MUEBLE	PLANO	C-1459
------	------------------------------	------	--------	-------	--------

ITEM	CODIGO	DENOMINACION	TEXTO	HMM-20/11	HME-20/11	HMP-20/11	HMM-20/11 UL	MFHMM-20/11					NOTAS
1	R662813	Pasamuros chimenea		1	1	1	1	1					
2	N503017	Soporte termostato		1	1	1	1	1					Pasamuros chimenea
3	R092832	Panel superior		1	1	1	1	1					
	Q221343	Remache exagonal M-6		4	4	4	4	4					Amarre panel superior a laterales
	Q232040	Arandela plana A-6		4	4	4	4	4					Amarre panel superior a laterales
	Q262040	Arandela muelle A-6		4	4	4	4	4					Amarre panel superior a laterales
	Q012042	Tornillo exagonal M-6x15		4	4	4	4	4					Amarre panel superior a laterales
4	R662811	Fijacion portamandos		1	1	1	1	1					
5	Q412002	Remache tubular Ø 4x7,5		2	2	2	2	2					
6	R092831	Panel lateral derecho		1	1	1	1	1					
7	Q152017	Tornillo amarre M-6x13		7	7	7	7	7					
8	3715400	Junta panel portamandos L=130		1	1	1	1	1					
9	R743012	Serigrafia superior (controlador)		1	-	-	-	-					
9	R673000	Serigrafia superior (controlador)		-	1	1	-	-					
9	R743070	Serigrafia superior (controlador)		-	-	-	1	-					
9	R743020	Serigrafia superior (controlador)		-	-	-	-	1					
10	R693000	Serigrafia inferior (conmutador)		1	-	-	1	-					
10	R663014	Serigrafia inferior (neutra)		-	1	-	-	-					
10	R663010	Serigrafia inferior (programador)		-	-	1	-	-					
10	R693031	Serigrafia inferior (conmutador)		-	-	-	-	1					
11	3715400	Junta panel portamandos L=1400		2	2	2	2	2					
12	R772805	Panel portamandos		1	-	-	1	1					
12	R092837	Panel portamandos		-	1	1	-	-					
13	Q232040	Arandela plana A-6		2	2	2	2	2					
14	Q262040	Arandela muelle A-6		2	2	2	2	2					
15	Q012042	Tornillo exagonal M-6x15		2	2	2	2	2					
16	R092809	Panel lateral izquierdo		1	1	1	1	1					
17	Q012042	Tornillo exagonal M-6x15		8	8	8	8	8					
18	Q262040	Arandela muelle A-6		8	8	8	8	8					

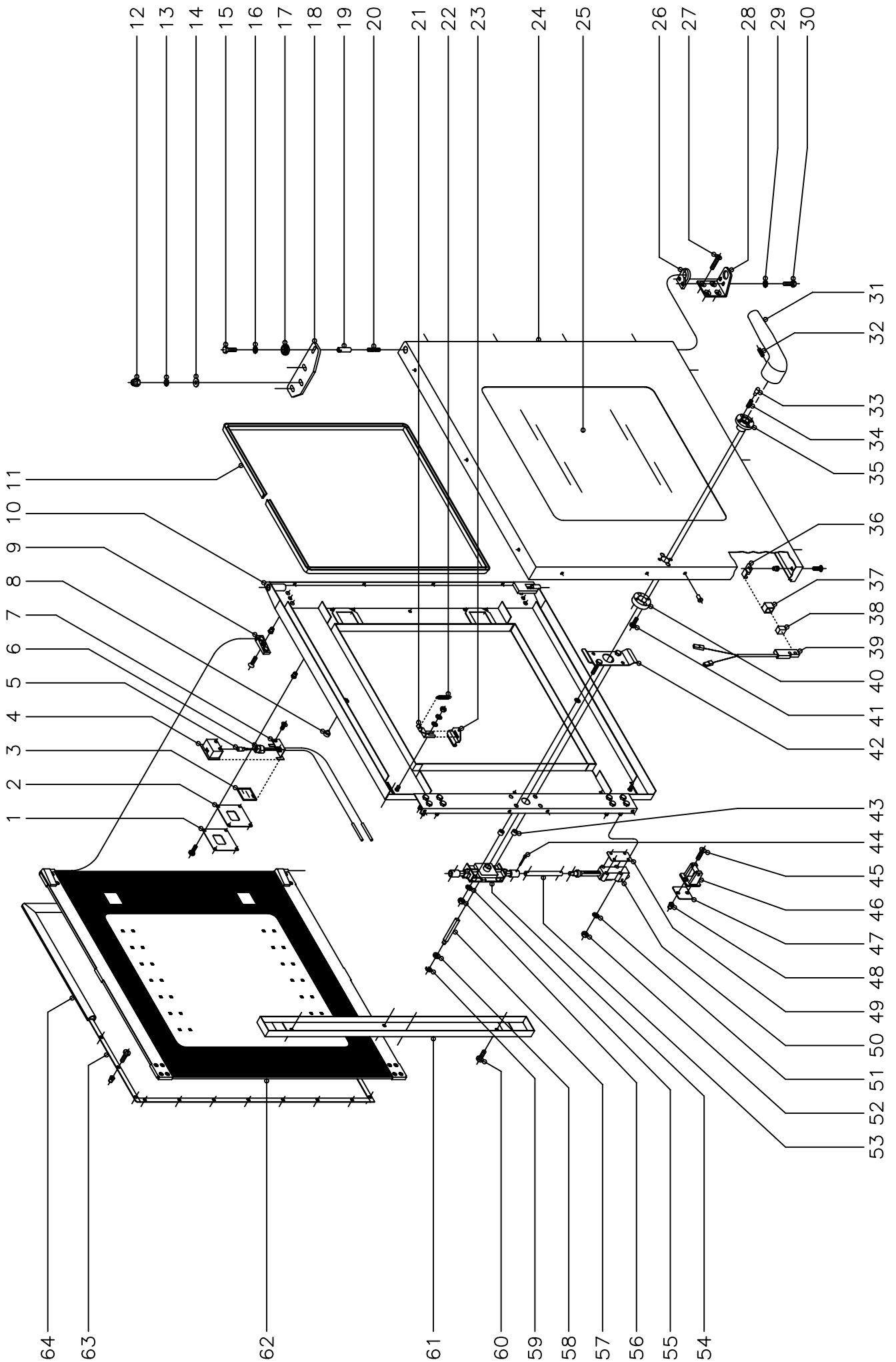

N plano
C-1460

Firma
[Signature]

Fecha
11-2003

Aparato
PUERTA
HORNOS HMM, HME, HMP-20/11

Lamina
2

Fagor Industrial S.Coop. **FAGOR**
Oñate

MOD.	HORNOS : HMM, HME, HMP-20/11	ZONA	PUERTA	PLANO	C-1460
------	------------------------------	------	--------	-------	--------

ITEM	CODIGO	DENOMINACION	TEXTO	HMM-20/11	HME-20/11	HMP-20/11	HMM-20/11 UL	MFHMM-20/11					NOTAS
	1100002597	KIT Puerta completa 20/11		1	1	1	1	1					
1	R670608	Tapa cierre lampara		2	2	2	2	2					
	Q152004	Tornillo alomado M-5x13		8	8	8	8	8					
	Q222011	Remache exagonal M-5		8	8	8	8	8					
2	R670609	Junta cierre lampara		2	2	2	2	2					
3	R670618	Cristal de lampara		2	2	2	2	2					
4	R670610	Deflector de lampara		2	2	2	2	2					
5	R663013	Lampara 10 W. 12 V.		2	2	2	2	2					
6	R663058	Portalamparas		2	2	2	2	2					
7	R670611	Suplemento deflector		2	2	2	2	2					
	Q042031	Tornillo avellanado M-5x10		4	4	4	4	4					
8	R670617	Tope cristal interior		8	8	8	8	8					
9	R670615	Base de bisagra		2	2	2	2	2					
	Q042032	Tornillo avellanado M-5x15		2	2	2	2	2					
	Q222011	Remache exagonal M-5		2	2	2	2	2					
10	T100500	Contrapuerta completa 20/11		1	1	1	1	1					
11	3715200	Junta cristal L=3200		1	1	1	1	1					
12	Q212051	Tuerca sombrerete M-8		3	3	3	3	3					
13	Q242050	Arandela abanico A-8		3	3	3	3	3					
14	Q302025	Arandela plana Ø8,4xØ20x1,5		3	3	3	3	3					
15	Q012042	Tornillo exagonal M-6x15		1	1	1	1	1					
16	Q242040	Arandela abanico A-6		1	1	1	1	1					
17	R662807	Arandela amarre puerta		1	1	1	1	1					
18	T130500	Bisagra superior		1	1	1	1	1					
19	R660534	Eje superior		1	1	1	1	1					
20	Z850519	Resorte		1	1	1	1	1					
21	R670612	Base de pestillo		2	2	2	2	2					
	Q302022	Arandela plana Ø16xØ6x1,2		2	2	2	2	2					

MOD.	HORNOS : HMM, HME, HMP-20/11	ZONA	PUERTA	PLANO	C-1460
------	------------------------------	------	--------	-------	--------

ITEM	CODIGO	DENOMINACION	TEXTO	HMM-20/11	HME-20/11	HMP-20/11	HMM-20/11 UL	MFHMM-20/11						NOTAS
	Q242040	Arandela abanico A-6		2	2	2	2	2						
	Q162040	Tuerca exagonal M-6		2	2	2	2	2						
22	R660605	Muelle tensor pestillo		2	2	2	2	2						
23	R670613	Pestillo sujecion cristal interior		2	2	2	2	2						
24	R090600	Panel puerta 20/11		1	1	1	1	1						
	Q412002	Remache tubular Ø4x7,5		16	16	16	16	16						
25	R090605	Cristal exterior 20/11		1	1	1	1	1						
26	R660549	Guia eje inferior		1	1	1	1	1						
27	Q062040	Tornillo avellanado M-6x16		4	4	4	4	4						
28	R660551	Bisagra inferior		1	1	1	1	1						
29	Q242040	Arandela abanico A-6		2	2	2	2	2						
30	Q012041	Tornillo exagonal M-6x10		2	2	2	2	2						
31	T130502	Manilla		1	1	1	1	1						
32	Q132042	Varilla roscada M-6x15		1	1	1	1	1						
33	T130507	Piton enganche		2	2	2	2	2						
34	T130506	Resorte		2	2	2	2	2						
35	T130515	Guia manilla		1	1	1	1	1						
36	T130513	Soporte iman		1	1	1	1	1						
37	Z200507	Protector iman		1	1	1	1	1						
38	Z200506	Iman		1	1	1	1	1						
39	Z100522	Interruptor magnetico		1	1	1	1	1						
40	T130514	Soporte resortes		1	1	1	1	1						
41	Q032032	Tornillo alomado M-5x15		2	2	2	2	2						
42	T130511	Suplemento fijacion cerradura		1	1	1	1	1						
43	Z608410	Casquillo		2	2	2	2	2						
44	Q352001	Pasador de aletas Ø2x15		4	4	4	4	4						
45	Q042043	Tornillo avellanado M-6x20		4	4	4	4	4						
46	R260545	Enganche		2	2	2	2	2						
47	R660538	Calzo de enganche		6	6	6	6	6						

MOD.		HORNOS : HMM, HME, HMP-20/11		ZONA	PUERTA					PLANO	C-1460		
ITEM	CODIGO	DENOMINACION	TEXTO	HMM-20/11	HME-20/11	HMP-20/11	HMM-20/11 UL	MFHMM-20/11					NOTAS
48	Q221343	Remache exagonal M-6		4	4	4	4	4					
49	T080503	Suplemento elemento cierre		6	6	6	6	6					
50	T080504	Elemento de cierre		2	2	2	2	2					
51	Q262040	Arandela muelle A-6		8	8	8	8	8					
52	Q162040	Tuerca exagonal M-6		8	8	8	8	8					
53	R090514	Tabo alargadera		2	2	2	2	2					
54	T130509	Mecanismo de cierre		1	1	1	1	1					
55	Q262040	Arandela muelle A-6		2	2	2	2	2					
56	Q162040	Tuerca exagonal M-6		2	2	2	2	2					
57	T130508	Eje de manilla		1	1	1	1	1					
58	T130505	Casquillo		1	1	1	1	1					
59	Q271033	Arandela de seguridad Ø6		1	1	1	1	1					
60	Q032031	Tornillo alomado M-5x10		2	2	2	2	2					
60	Q032021	Tornillo alomado M-4x10		2	2	2	2	2					
61	T140502	Tapa cierre puerta		1	1	1	1	1					
62	1100002809	KIT Cristal interior completo 20/11		1	1	1	1	1					
63	R090512	Fijacion junta completa 20/11		1	1	1	1	1					
	Q033021	Tornillo alomado M-4x10 (laton)		40	40	40	40	40					
	Q222041	Remache exagonal M-4 inox.		40	40	40	40	40					
64	R090510	Junta de puerta 20/11		1	1	1	1	1					

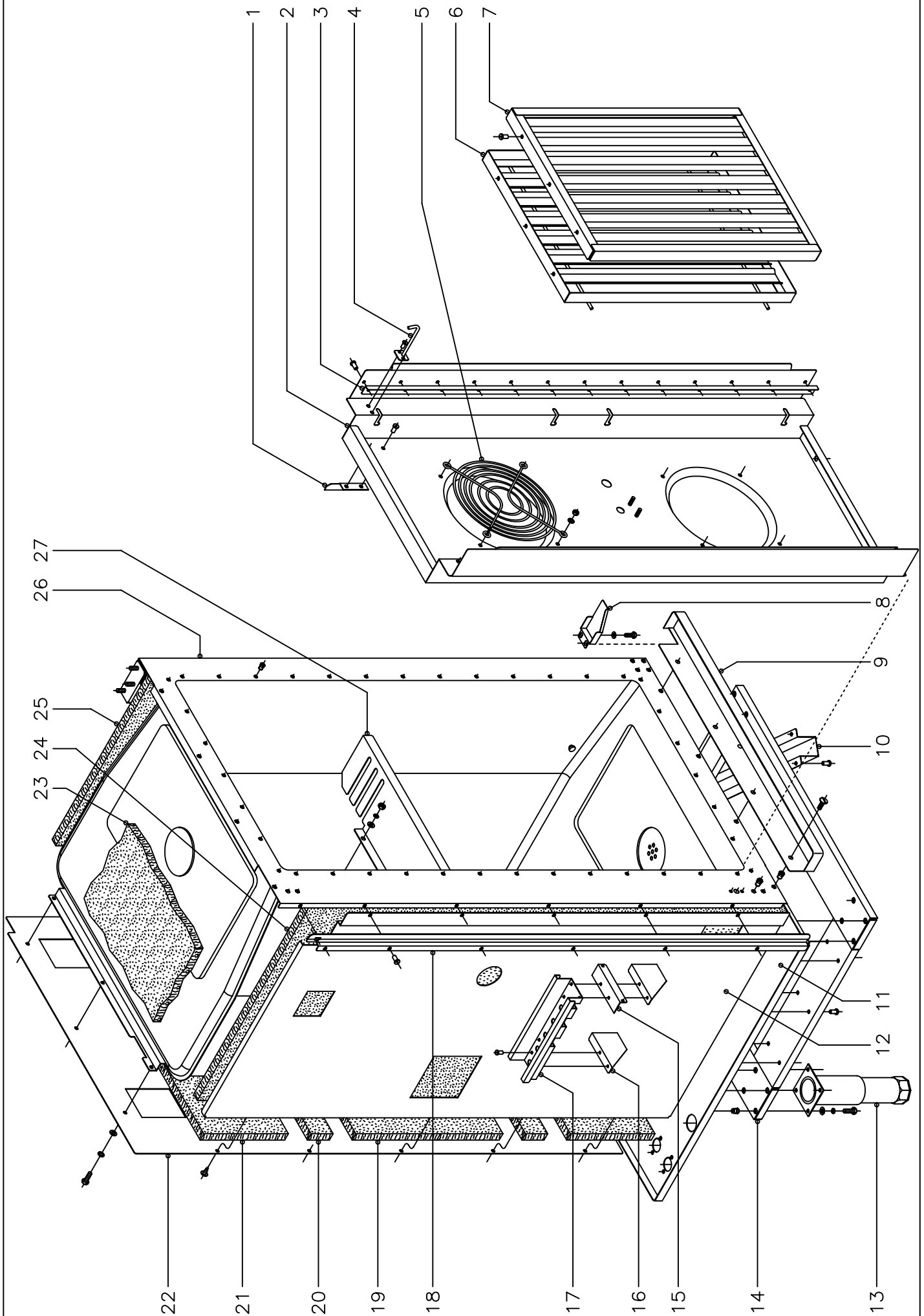

N plano
C-1461

Firma
[Signature]

Fecha
11-2003

Aparato
MUEBLE INTERIOR
HORNOS HMM, HME, HMP-20/11

Lamina
3

Fagor Industrial S.Coop. **FAGOR**
Onate



MOD.	HORNOS : HMM, HME, HMP-20/11	ZONA	MUEBLE INTERIOR	PLANO	C-1461
------	------------------------------	------	-----------------	-------	--------

ITEM	CODIGO	DENOMINACION	TEXTO	HMM-20/11	HME-20/11	HMP-20/11	HMM-20/11 UL	MFHMM-20/11						NOTAS
1	R292647	Escuadra sujecion cubreventilador		2	2	2	2	2						
	Q412002	Remache tubular Ø 4x7,5		4	4	4	4	4						
2	R092636	Cubre ventilador		1	1	1	1	1						
3	R092616	Tope cubreventilador		2	2	2	2	2						
	Q412002	Remache tubular Ø 4x7,5		26	26	26	26	26						
4	R142615	Fijacion portabandejas		2	2	2	2	2						
	Q412002	Remache tubular Ø 4x7,5		4	4	4	4	4						
5	R662661	Proteccion de turbina		-	-	-	1	1						
	Q032021	Tornillo alomado M-4x10		-	-	-	4	4						
	Q242020	Arandela abanico A-4		-	-	-	4	4						
	Q162020	Tuerca exagonal M-4		-	-	-	4	4						
6	R092621	Posterior de filtro		2	2	2	2	2						
7	R092618	Anterior de filtro		2	2	2	2	2						
	Q412002	Remache tubular Ø 4x7,5		12	12	12	12	12						
8	R662800	Cubrecables		1	1	1	1	1						
	Q221342	Remache exagonal M-5		2	2	2	2	2						
	Q232030	Arandela plana A-5		2	2	2	2	2						
	Q012031	Tornillo exagonal M-5x10		2	2	2	2	2						
9	T112813	Recogeaguas		1	1	1	1	1						
	Q221343	Remache exagonal M-6		4	4	4	4	4						
	Q152017	Tornillo amarre M-6x13		4	4	4	4	4						
10	R092819	Cubredesagüe		1	1	1	1	1						
	Q412002	Remache tubular Ø 4x7,5		8	8	8	8	8						
11	R092827	Base exterior de horno		1	1	1	1	1						
12	T132610	Soporte lateral aislante		1	1	1	1	1						
13	R092830	Pata regulable		4	4	4	4	4						
	Q012043	Tornillo exagonal M-6x20		16	16	16	16	16						
	Q262040	Arandela muelle A-6		16	16	16	16	16						
	Q232040	Arandela plana A-6		16	16	16	16	16						

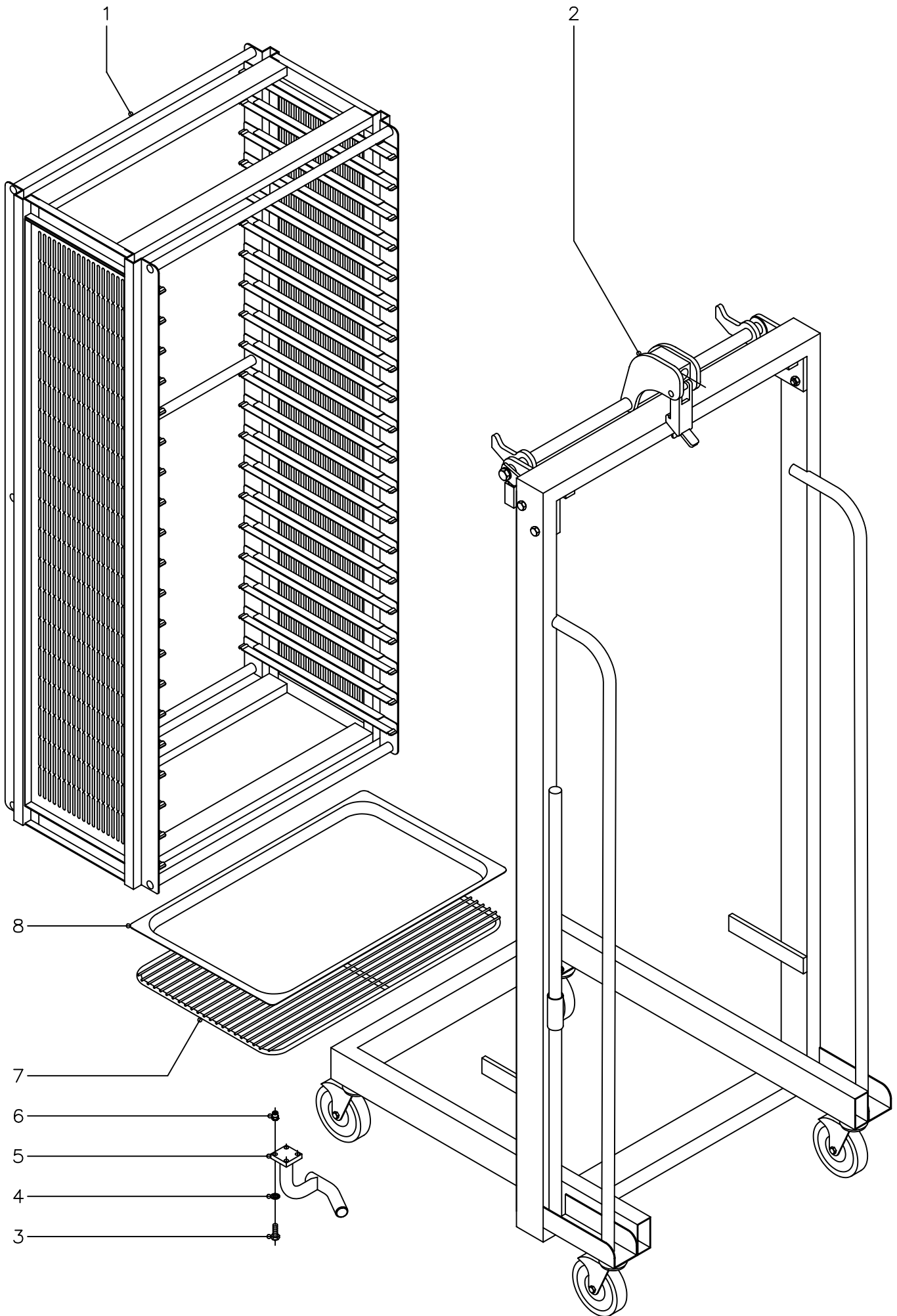

MOD.	HORNOS : HMM, HME, HMP-20/11	ZONA	MUEBLE INTERIOR	PLANO	C-1461
------	-------------------------------------	------	------------------------	-------	---------------

ITEM	CODIGO	DENOMINACION	TEXTO	HMM-20/11	HME-20/11	HMP-20/11	HMM-20/11 UL	MFHMM-20/11					NOTAS
	Q221343	Remache exagonal M-6		16	16	16	16	16					
14	T132816	Refuerzo de apoyos		1	1	1	1	1					
	Q412002	Remache tubular Ø 4x7,5		24	24	24	24	24					
15	R092611	Fijacion a panel lateral		1	1	1	1	1					
16	R092610	Refuerzo base de cuadro		2	2	2	2	2					
17	R342821	Guia cuadro electrico		1	1	1	1	1					
	Q411304	Remache avibulb Ø 4,8		10	10	10	10	10					
18	R092662	Protector de portamandos		1	1	1	1	1					
	Q412002	Remache tubular Ø 4x7,5		6	6	6	6	6					
19	R092624	Aislante central 670x400x20		1	1	1	1	1					
20	R662616	Aislante entre refuerzos 560x60x20		6	6	6	6	6					
21	R672631	Aislante supe. e inferior 670x230x20		2	2	2	2	2					
22	R092652	Soporte aislante posterior		1	1	1	1	1					
	Q151301	Tornillo alomado		5	5	5	5	5					
	Q012042	Tornillo exagonal M-6x15		15	15	15	15	15					
	Q262040	Arandela muelle A-6		15	15	15	15	15					
	Q232040	Arandela plana A-6		15	15	15	15	15					
23	R662614	Aislante base y techo 650x650x20		5	5	5	5	5					
24	R092622	Aislante lateral 1370x650x20		3	3	3	3	3					
25	R092622	Aislante lateral 1370x650x20		2	2	2	2	2					
26	R092660	Cuerpo interior horno		1	1	1	1	1					
27	R092628	Separador central		1	1	1	1	1					
	Q232040	Arandela plana A-6		2	2	2	2	2					
	Q262040	Arandela muelle A-6		2	2	2	2	2					
	Q162040	Tuerca exagonal M-6		2	2	2	2	2					

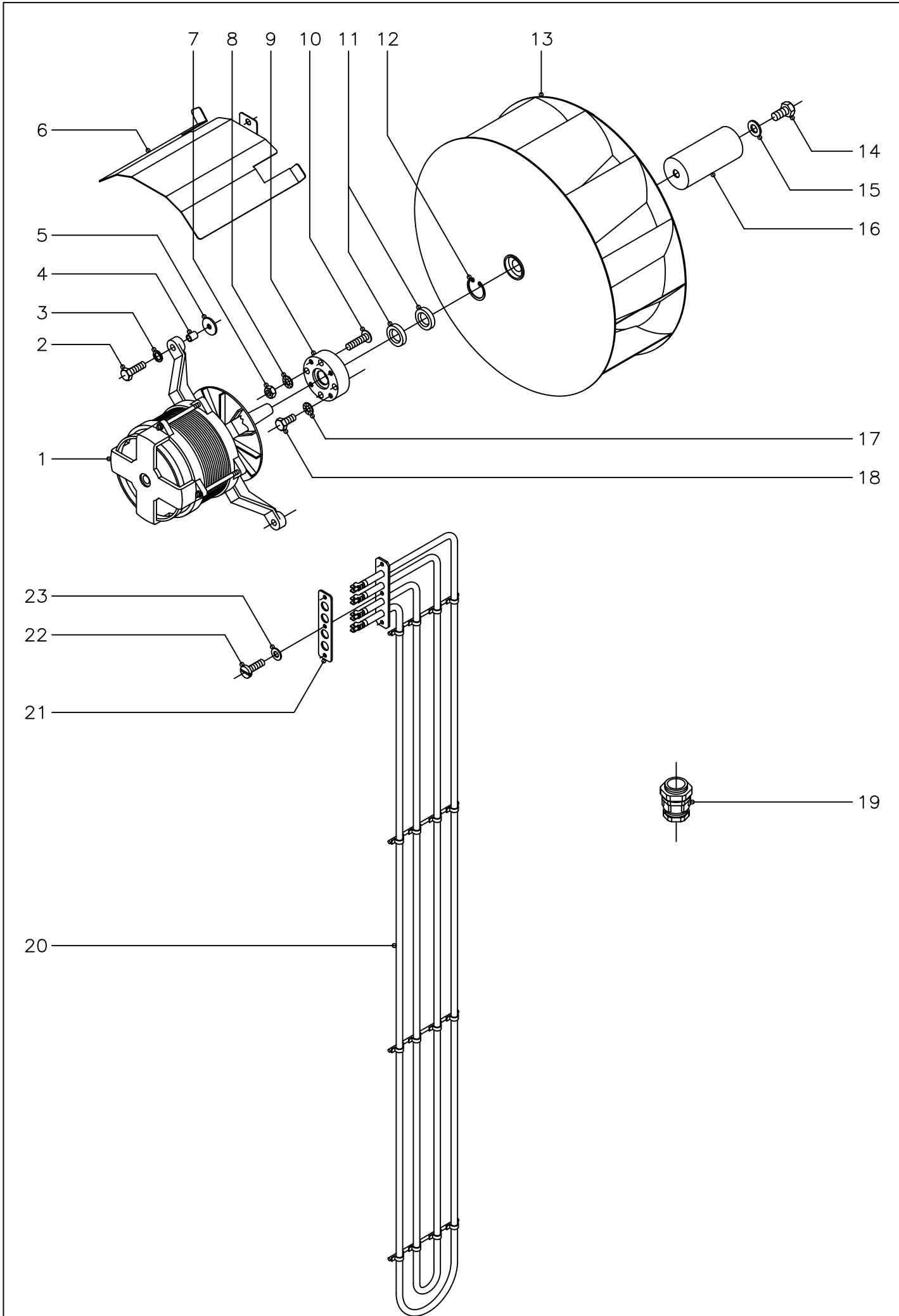

N plano C-1462	Firma 	Fecha 11-2003	Aparato CARRO Y EXTRACTURA PORTABANDEJAS HORNOS HMM, HME, HMP-20/11	Lamina 4	Fagor Industrial S.Coop. FAGOR  Oñate
-------------------	--	------------------	---	-------------	--



N plano C-1463	Firma 	Fecha 11-2003	Aparato TURBINA HORNOS HMM, HME, HMP-20/11	Lamina 5	Fagor Industrial S.Coop. FAGOR  Ofite
-------------------	--	------------------	--	-------------	--

MOD.	HORNOS : HMM, HME, HMP-20/11	ZONA	TURBINA	PLANO	C-1463
------	------------------------------	------	---------	-------	--------

ITEM	CODIGO	DENOMINACION	TEXTO	HMM-20/11	HME-20/11	HMP-20/11	HMM-20/11 UL	MFHMM-20/11						NOTAS
1	R253049	Motor (220/240,380/415 V.,50/60 Hz.)		2	-	-	2	2						Trifasico
1	R663033	Motor (380/400 V., 50/60 Hz.)		-	2	2	-	-						Trifasico
1	R663034	Motor (220/230 V., 50/60 Hz.)		-	2	2	-	-						Trifasico
2	Q012044	Tornillo exagonal M-6x25		8	8	8	8	8						
3	Q262040	Arandela muelle A-6		8	8	8	8	8						
4	R663057	Casquillo amarre motor		-	8	8	-	-						
5	Q301304	Arandela calzo Ø 23xØ 6,5x2		8	8	8	8	8						
6	R142628	Tejadillo motor		2	2	2	2	2						
	Q012042	Tornillo exagonal M-6x15		2	2	2	2	2						
7	Q162040	Tuerca exagonal M-6		8	8	8	8	8						
8	Q262040	Arandela muelle A-6		8	8	8	8	8						
9	R662623	Casquillo reten		2	2	2	2	2						
10	-	Perno M-6 (Caldeado a cuerpo)		8	8	8	8	8						
11	R662627	Reten Ø 28xØ 17x7		4	4	4	4	4						
12	Q302023	Anillo de seguridad Ø 28x1,2		2	2	2	2	2						
13	R253042	Turbina		2	2	2	2	2						
14	Q012063	Tornillo exagonal M-10x20		2	2	2	2	2						
15	R763010	Arandela seguridad Hanning		2	2	2	2	2						
16	R665025	Distribuidor inyeccion		-	1	1	-	-						
17	Q232030	Arandela muelle A-5		8	8	8	8	8						
18	Q012031	Tornillo exagonal M-5x10		8	8	8	8	8						
19	R033002	Prensaestopas		1	1	1	1	1						
20	R093002	Resistencia 2000+2000W., 230V.		6	6	6	6	6						
21	R673063	Junta resistencia		6	6	6	6	6						
22	Q062031	Tornillo alomado M-5x10		18	18	18	18	18						
23	Q232030	Arandela plana A-5		18	18	18	18	18						

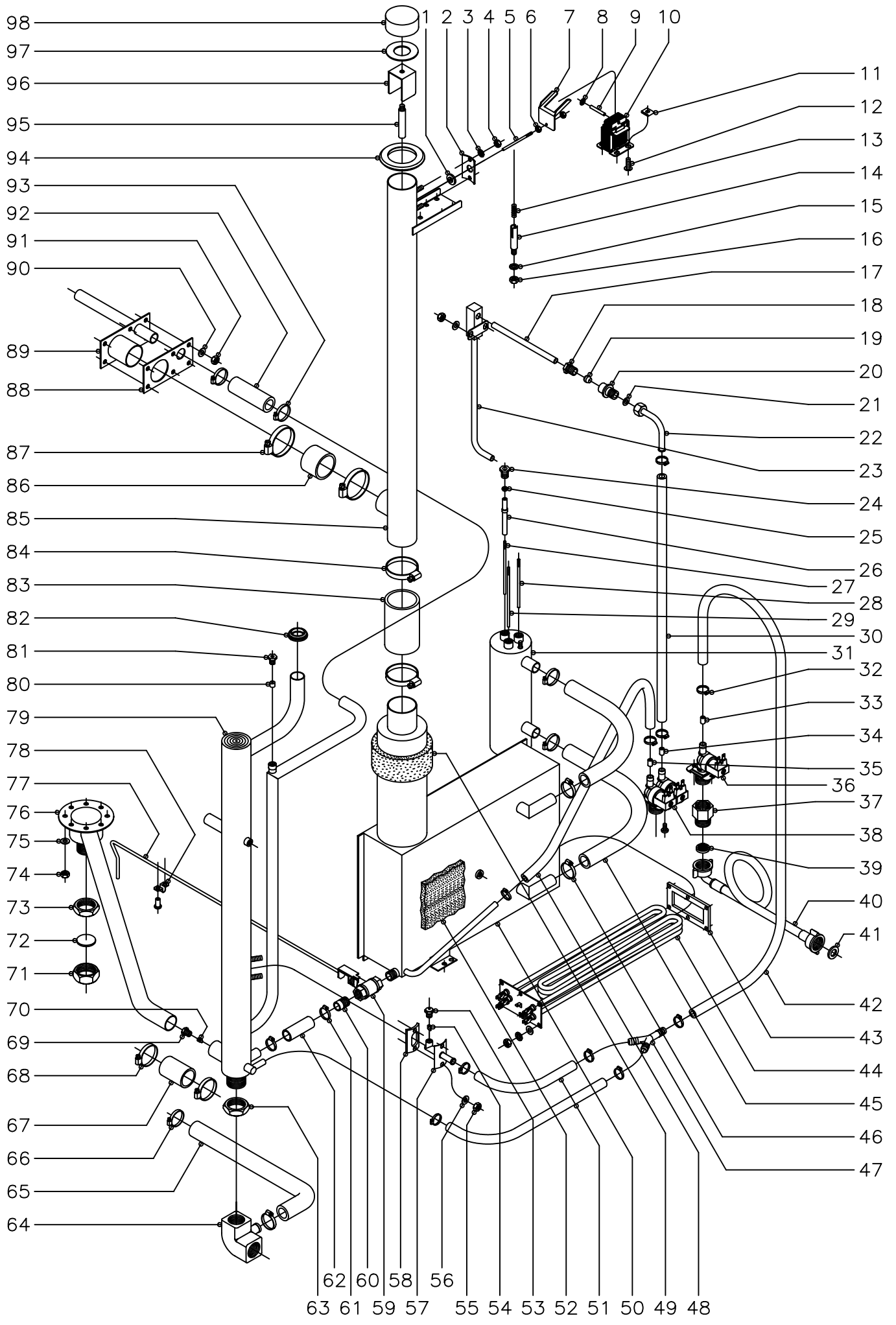

MOD.	HORNOS : HMM, HME, HMP-20/11	ZONA	CIRCUITO DE AGUA	PLANO	C-1464
------	------------------------------	------	------------------	-------	--------

ITEM	CODIGO	DENOMINACION	TEXTO	HMM-20/11	HME-20/11	HMP-20/11	HMM-20/11 UL	MFHMM-20/11						NOTAS
1	R675033	Junta palanca accionamiento		1	1	1	1	1						
2	T115105	Amarre junta a conduccion vahos		1	1	1	1	1						
3	Q242030	Arandela abanico A-5		2	2	2	2	2						
4	Q162030	Tuerca exagonal M-5		2	2	2	2	2						
5	R675014	Palanca accionamiento		1	1	1	1	1						
6	Q162020	Tuerca exagonal M-4		2	2	2	2	2						
7	R672640	Escuadra accionamiento		1	1	1	1	1						
8	Q301035	Sujecion rapida Ø4		2	2	2	2	2						
9	R675016	Pasador electroiman		1	1	1	1	1						
10	R663030	Electroiman		1	1	1	1	1						
11	Q221012	Tuerca rapida M-5		2	2	2	2	2						
12	Q152004	Tornillo aplastado M-5x13		2	2	2	2	2						
13	Z883001	Resorte		1	1	1	1	1						
14	R665027	Guia resorte		1	1	1	1	1						
15	Q242040	Arandela abanico A-6		1	1	1	1	1						
16	Q162040	Tuerca exagonal M-6		1	1	1	1	1						
17	R665024	Tubo conduccion a inyector		-	1	1	-	-						
18	R695003	Manguito cierre		-	1	1	-	-						
19	R695004	Bicono		-	1	1	-	-						
20	-	Soldado a cuerpo de horno		-	1	1	-	-						
21	Q306025	Arandela junta Ø14xØ8,5x1,5		-	1	1	-	-						
22	R695017	Tubo conduccion agua		-	1	1	-	-						
23	R675017	Tubo inyector		-	1	1	-	-						
	Q232030	Arandela plana A-5		-	2	2	-	-						
	Q162030	Tuerca exagonal M-5		-	2	2	-	-						
24	R345058	Racord amarre electrodos		3	3	3	3	3						
25	Q163020	Tuerca exagonal M-4		6	6	6	6	6						
26	R345059	Guia aislante de electrodos		3	3	3	3	3						
27	R345063	Electrodo nivel bajo L=116		1	1	1	1	1						

MOD.	HORNOS : HMM, HME, HMP-20/11	ZONA	CIRCUITO DE AGUA	PLANO	C-1464
------	------------------------------	------	------------------	-------	--------

ITEM	CODIGO	DENOMINACION	TEXTO	HMM-20/11	HME-20/11	HMP-20/11	HMM-20/11 UL	MFHMM-20/11						NOTAS
28	R345060	Electrodo nivel alto L=106		1	1	1	1	1						
29	R345064	Electrodo de masa L=131		1	1	1	1	1						
30	3676900	Tubo de goma Ø17xØ10x1000		-	1	1	-	-						
31	R025011	Cuerpo de niveles		1	1	1	1	1						
32	Q881302	Abrazadera 12 - 20		4	6	6	4	4						
33	P443042	Regulador caudal (3 l./m.) negro		1	1	1	1	1						
34	R665041	Regulador caudal (0,25 l./m.) verde		-	1	1	-	-						
35	Z601156	Regulador caudal (8 l./m.) rojo		1	1	1	1	1						
36	Z701135	Electrovalvula simple		1	1	1	1	1						
37	T125033	Adaptador a rosca UL		-	-	-	1	1						
38	P255001	Electrovalvula doble		-	1	1	-	-						
38	Z701135	Electrovalvula simple		1	-	-	1	1						
	Q032021	Tornillo alomado M-4x10		4	4	4	4	4						
39	Z701132	Filtro-junta entrada de agua		1	1	1	-	-						
40	Z601114	Manguera entrada de agua		2	2	2	-	-						
41	Q307031	Arandela junta Ø24xØ14x3		2	2	2	-	-						
42	3676900	Tubo de goma Ø17xØ10x900		1	1	1	1	1						
43	R145012	Junta cierre resistencias		2	2	2	2	2						
44	R143000	Resistencia (3000W.x3, 230 V.)		2	2	2	2	2						
	Q232030	Arandela plana A-5		12	12	12	12	12						
	Q242030	Arandela abanico A-5		12	12	12	12	12						
	Q162030	Tuerca exagonal M-5		12	12	12	12	12						
45	3715600	Tubo silicona forra. Ø26xØ18x400		2	2	2	2	2						
46	Q881305	Abrazadera 25 - 40		4	4	4	4	4						
47	Z201106	Racord en " Y "		1	1	1	1	1						
48	3676900	Tubo de goma Ø17xØ10x500		1	1	1	1	1						
49	R345013	Aislante salida generador		1	1	1	-	-						
49	R672630	Aislante salida generador		-	-	-	1/2.	1/2.						
50	R675024	Generador de vapor		1	1	1	1	1						

MOD.	HORNOS : HMM, HME, HMP-20/11	ZONA	CIRCUITO DE AGUA	PLANO	C-1464
------	------------------------------	------	------------------	-------	--------

ITEM	CODIGO	DENOMINACION	TEXTO	HMM-20/11	HME-20/11	HMP-20/11	HMM-20/11 UL	MFHMM-20/11						NOTAS
51	3676900	Tubo de goma Ø17xØ10x400		2	2	2	2	2						
52	R345011	Aislante cuerpo generador		1	1	1	-	-						
52	R672630	Aislante cuerpo generador		-	-	-	1/2.	1/2.						
53	Z651931	Tobera		1	1	1	1	1						
54	Z651932	Rodete		1	1	1	1	1						
55	Q162030	Tuerca exagonal M-5		2	2	2	2	2						
56	Q232030	Arandela plana A-5		2	2	2	2	2						
57	R015007	Conduccion vahos		1	1	1	1	1						
58	R345108	Junta conduccion vahos		1	1	1	1	1						
59	R015034	Cuerpo grifo vaciado		1	1	1	1	1						
60	R345014	Manguito grifo vaciado		1	1	1	1	1						
61	Q881304	Abrazadera 20 - 32		2	2	2	2	2						
62	3715600	Tubo silicona Ø26xØ18x120		1	1	1	1	1						
63	Q223014	Contratuerca 1"		1	1	1	1	1						
64	R665067	Codo desague		1	1	1	1	1						
65	3715600	Tubo silicona Ø26xØ18x1000		1	1	1	1	1						
66	Q881304	Abrazadera 20 - 32		2	2	2	2	2						
67	3714100	Tubo silicona Ø38xØ31x100		1	1	1	1	1						
68	Q881305	Abrazadera 25 - 40		2	2	2	2	2						
69	Z651931	Tobera		1	1	1	1	1						
70	Z651932	Rodete		1	1	1	1	1						
71	R665053	Tuerca tapon 1"		1	1	1	1	1						
72	R015011	Arandela junta tapon Ø34x3		1	1	1	1	1						
73	Q223014	Contratuerca 1"		1	1	1	1	1						
74	Q162040	Tuerca exagonal M-6		8	8	8	8	8						
75	Q232040	Arandela plana A-6		8	8	8	8	8						
76	R675022	Tubo de desague		1	1	1	1	1						
77	R342803	Palanca de grifo de vaciado		1	1	1	1	1						
78	Q901306	Grapa amarre palanca grifo		1	1	1	1	1						

MOD.	HORNOS : HMM, HME, HMP-20/11	ZONA	CIRCUITO DE AGUA	PLANO	C-1464
------	------------------------------	------	------------------	-------	--------

ITEM	CODIGO	DENOMINACION	TEXTO	HMM-20/11	HME-20/11	HMP-20/11	HMM-20/11 UL	MFHMM-20/11					NOTAS
	Q412002	Remache tubular Ø 4x7,5		2	2	2	2	2					
79	R095008	Tubo retorno y chimenea		1	1	1	1	1					
80	3712400	Tubo-junta de silicona Ø8xØ3x20		1	1	1	1	1					
81	R662629	Racord cierre sonda		1	1	1	1	1					
82	N503017	Soporte termostato		1	1	1	1	1					Pasamuros chimenea
83	R345020	Tubo empalme generador		1	1	1	1	1					
84	Q881307	Abrazadera 40 - 60		2	2	2	2	2					
85	R095004	Conjunto chimenea		1	1	1	1	1					
86	3710900	Tubo silicona Ø51xØ43x40		1	1	1	1	1					
87	Q881307	Abrazadera 40 - 60		2	2	2	2	2					
88	R675038	Junta entrada y retorno		1	1	1	1	1					
89	R022613	Tubo entrada y retorno vapor		1	1	1	1	1					
90	Q232040	Arandela plana A-6		6	6	6	6	6					
91	Q162040	Tuerca exagonal M-6		6	6	6	6	6					
92	3715600	Tubo silicona forra. Ø26xØ18x100		1	1	1	1	1					
93	Q881304	Abrazadera 20 - 32		2	2	2	2	2					
94	R662813	Pasamuros chimenea		1	1	1	1	1					
95	R675008	Union retencion de vapores		1	1	1	1	1					
96	R675005	Guia retencion de vapores		1	1	1	1	1					
97	R675007	Junta retencion de vapores		1	1	1	1	1					
98	R675006	Retencion de vapores		1	1	1	1	1					

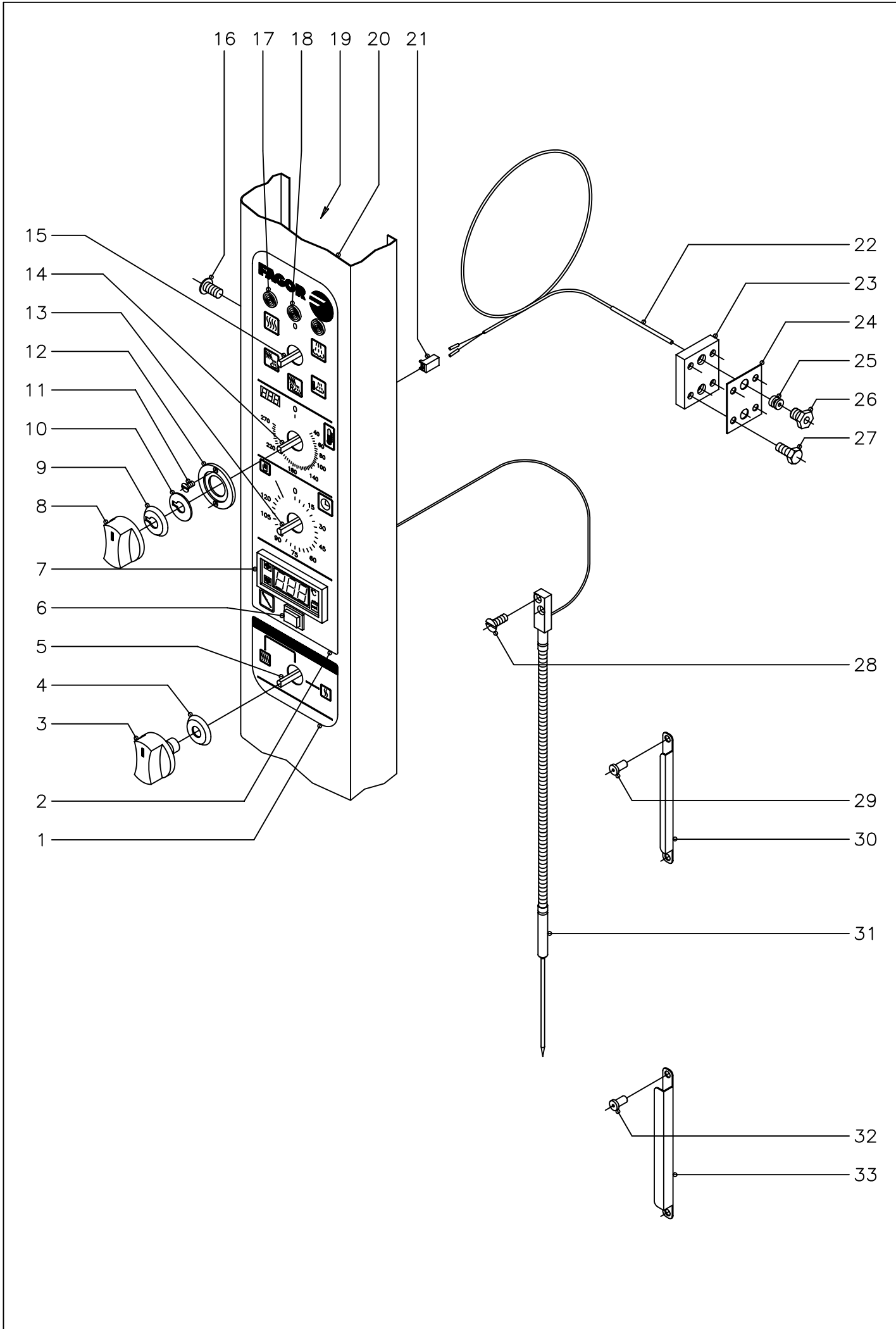

N plano C-1465	Firma 	Fecha 11-2003	Aparato SISTEMA ELECTRICO PORTAMANDOS HORNO HMM-20/11	Lamina 7	Fagor Industrial S.Coop. FAGOR Onate
-------------------	--	------------------	---	-------------	--

MOD.	HORNOS : HMM-20/11	ZONA	SISTEMA ELECTRICO PORTAMANDOS	PLANO	C-1465
------	--------------------	------	-------------------------------	-------	--------

ITEM	CODIGO	DENOMINACION	TEXTO	HMM-20/11	HMM-20/11 UL	MFHMM-20/11								NOTAS
1	R693000	Serigrafia inferior (conmutador)		1	1	-								
1	R693031	Serigrafia inferior (conmutador)		-	-	1								
2	R743012	Serigrafia superior (controlador)		1	-	-								
2	R743070	Serigrafia superior (controlador)		-	1	-								
2	R743020	Serigrafia superior (controlador)		-	-	1								
3	R663062	Boton de mando (conmutadores)		3	3	-								FAGOR
3	R663070	Boton de mando (conmutadores)		-	-	3								MARKET-FORGE
4	R663046	Junta (conmutadores)		3	3	3								
5	R753000	Conmutador de potencia		1	1	1								
6	R743008	Interruptor regulacion sonda		1	1	1								
7	R743091	Termostato digital ° C.		1	-	-								
7	R743035	Termostato digital ° F.		-	1	1								
8	R663063	Boton de mando (circuito impreso)		1	1	-								FAGOR
8	R663071	Boton de mando (circuito impreso)		-	-	1								MARKET-FORGE
9	R663045	Junta (circuito impreso)		1	1	1								
10	R662810	Arandela guia		1	1	1								
11	Q151346	Tornillo avellanado M-3x5		2	2	2								
12	R662809	Guia boton de mando		1	1	1								
13	R723000	Temporizador manual		1	1	1								
14	R743013	Termostato electronico 270°C.		1	-	-								
14	R693058	Termostato electronico 500°F.		-	1	1								
15	R743002	Conmutador de funciones		1	1	1								
16	Q152004	Tornillo aplastado M-5x13		3	3	3								
17	R693056	Piloto ambar		2	2	2								
18	R693055	Piloto verde		1	1	1								
19	R742803	Soporte componentes		1	1	1								
20	R772805	Panel portamandos		1	1	1								
21	R663092	Conector 2 vias		1	1	1								
22	R663090	Conjunto termopar L=1500		1	1	1								

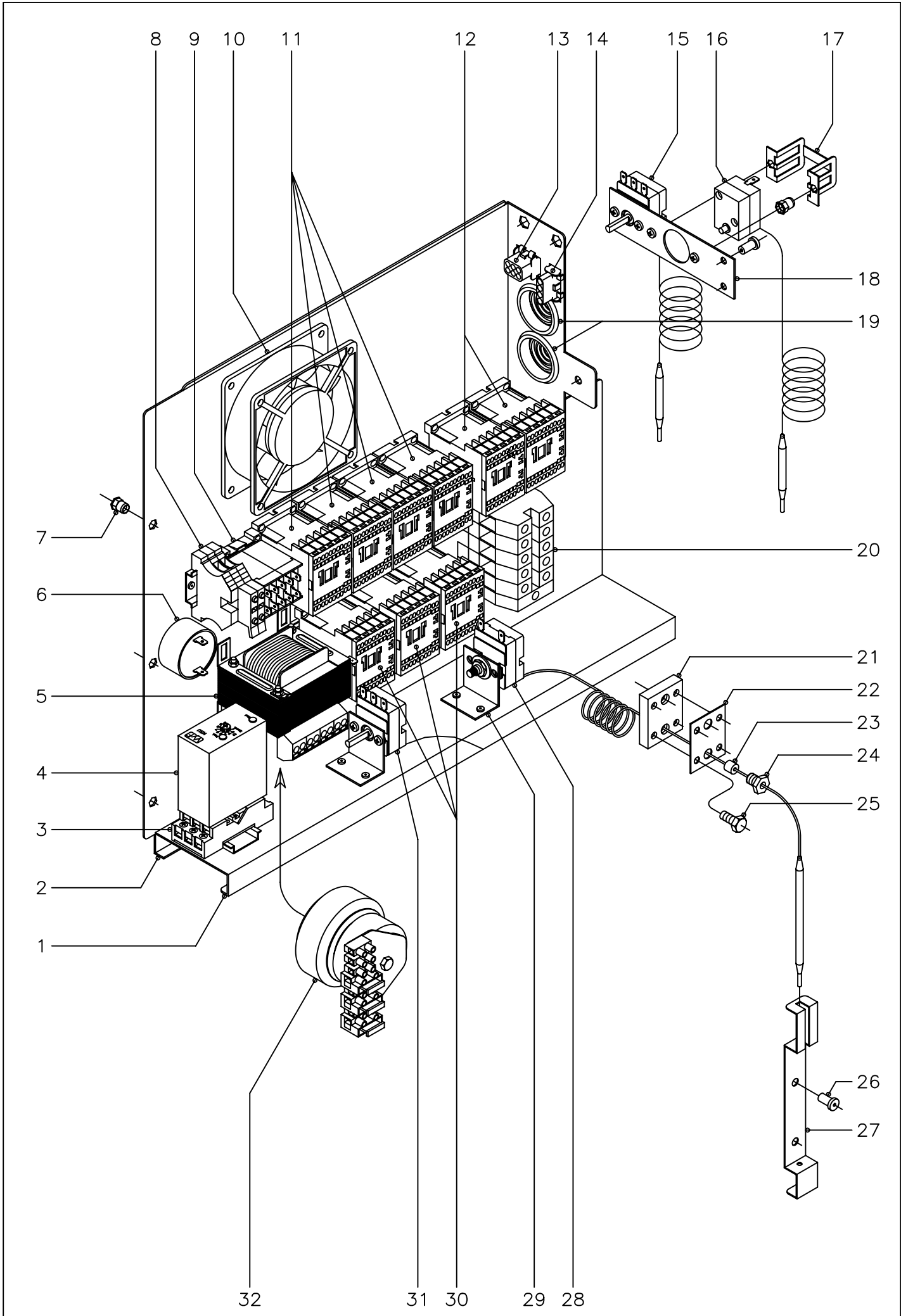

MOD.	HORNOS : HMM-20/11	ZONA	CUADRO ELECTRICO	PLANO	C-1466
------	--------------------	------	------------------	-------	--------

ITEM	CODIGO	DENOMINACION	TEXTO	HMM-20/11	HMM-20/11 UL	MFHMM-20/11								NOTAS
1	R663081	Panel cuadro electrico		1	1	1								
2	R663018	Contra guia panel cuadro		1	1	1								
	Q412002	Remache tubular Ø4x7,5		7	7	7								
3	R743009	Base enchufable		1	1	1								
	Z123018	Guia contactor L=55		1	1	1								
4	R343072	Detector de niveles		1	-	-								
4	R743031	Detector de niveles		-	1	1								
5	R503005	Transformador		1	1	1								
6	R693067	Zumbador		1	1	1								
7	Q221342	Remache exagonal M-5		3	3	3								
8	R073005	Bornas portafusibles		2	2	2								
	P184011	Cartucho fusible 4 A.		2	2	2								
	Z263303	Tope final		1	1	1								
9	Z683087	Contacto 3TF20 01 - 3AL2 (230 V.)		1	1	1								
	Z263303	Tope final		1	1	1								
10	Z103066	Ventilador		1	1	1								
11	Z203050	Contacto sirius 3RT-1016-2AP01		4	4	4								
	R693009	Guia contactor L=250		1	1	1								
12	Z203050	Contacto sirius 3RT-1016-2AP01		2	2	2								
	Z403016	Guia contactor L=100		1	1	1								
13	-	Conector hembra 6 vias		1	1	1								
14	-	Conector hembra 4 vias		1	1	1								
15	R343100	Termostato de condensacion		1	1	1								
	Q153111	Tornillo alomado M-4x8		2	2	2								
16	Z213014	Termostato Tecasa de seguridad		1	1	1								
17	Z203060	Amarre limitador Tecasa		1	1	1								
	Q221341	Remache exagonal M-4		2	2	2								
	Q153111	Tornillo alomado M-4x8		2	2	2								
18	R673061	Soporte amarre termostatos		1	1	1								

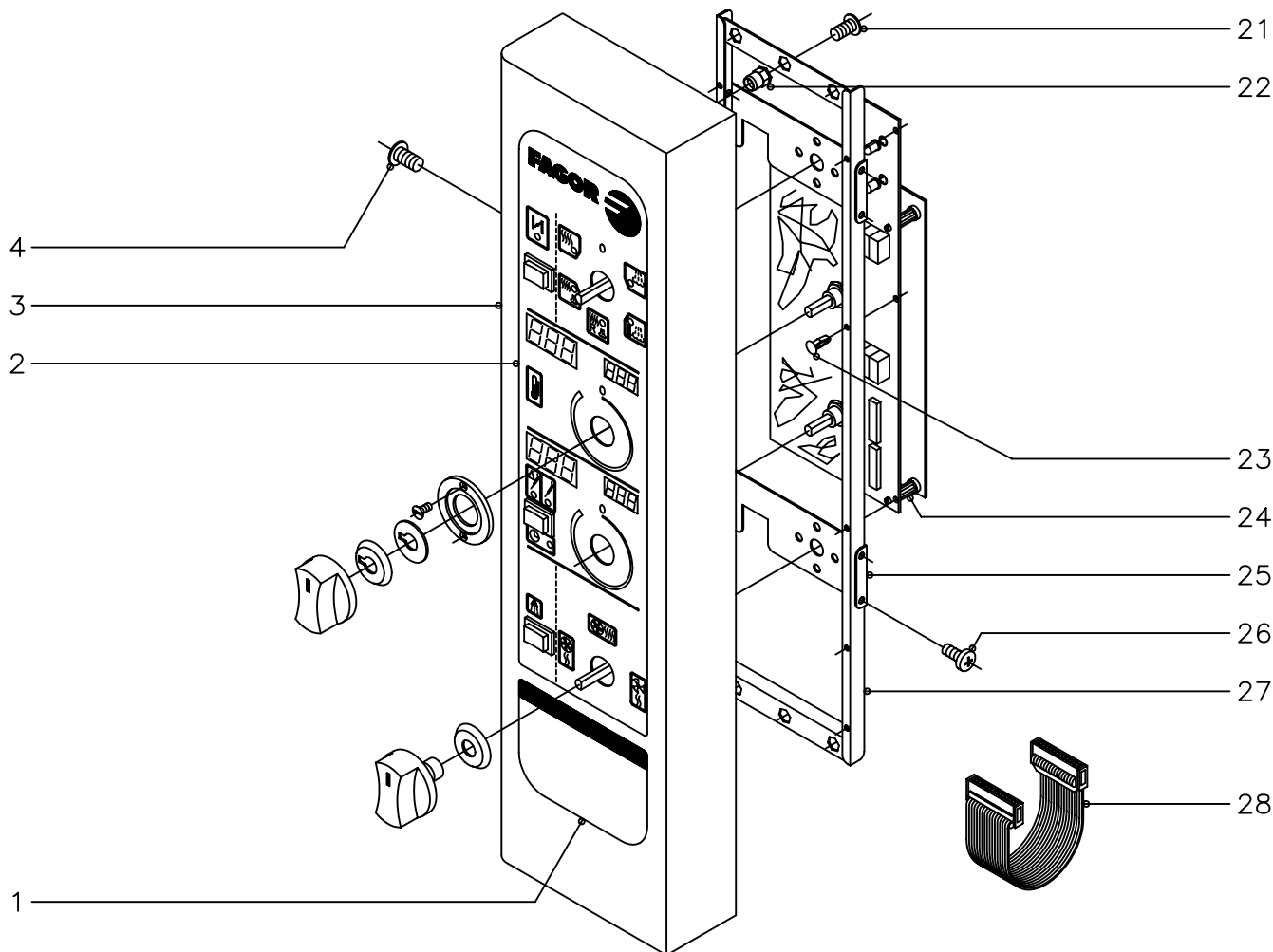
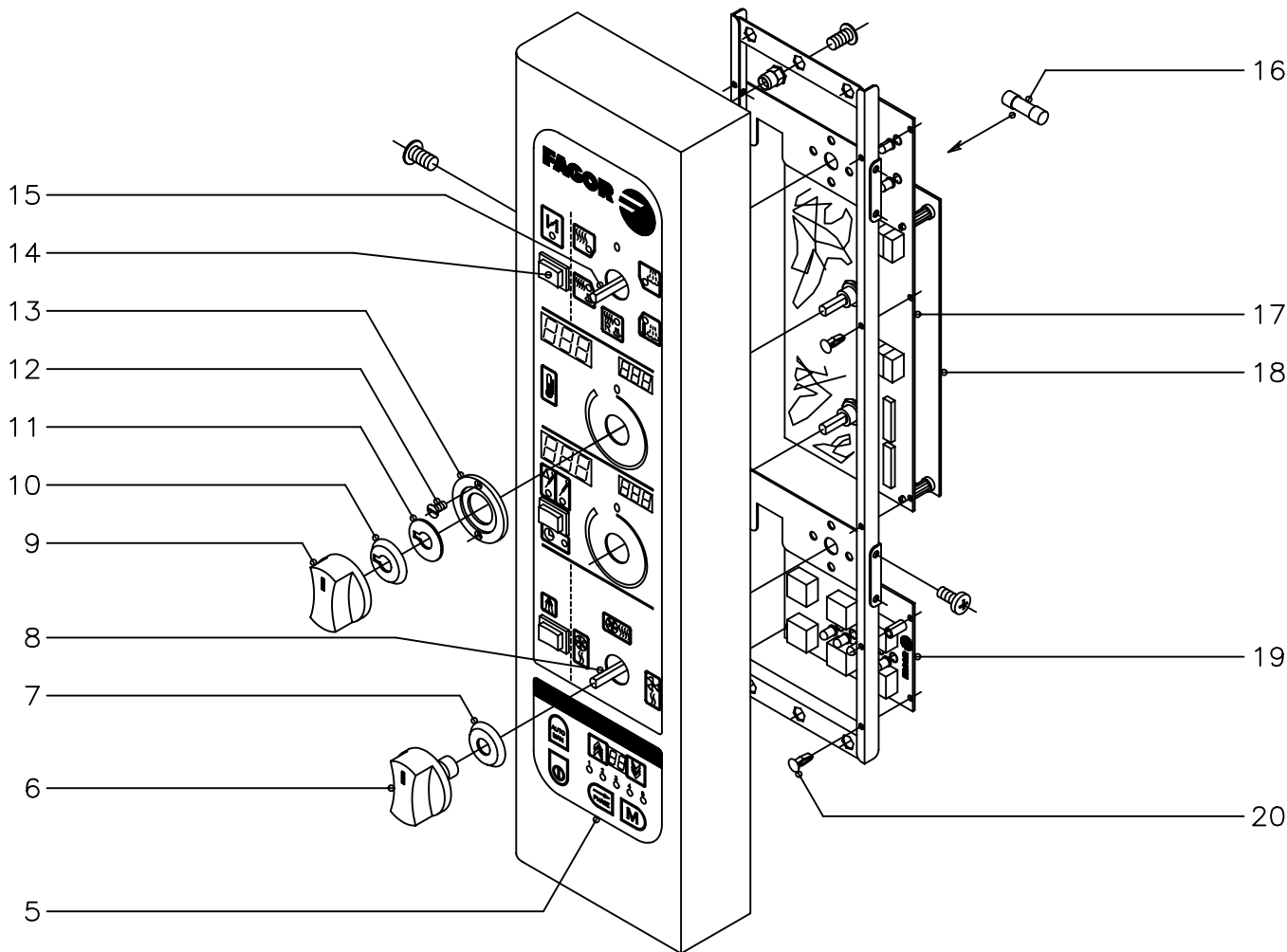

MOD.	HORNOS : HME, HMP-20/11	ZONA	SISTEMA ELECTRICO PORTAMANDOS	PLANO	C-1467
------	--------------------------------	------	--------------------------------------	-------	---------------

ITEM	CODIGO	DENOMINACION	TEXTO	HME-20/11	HMP-20/11									NOTAS
1	R663014	Serigrafia inferior (neutra)		1	-									
2	R673000	Serigrafia superior (controlador)		1	1									
3	R092837	Panel portamandos		1	1									
4	Q152004	Tornillo aplastado M-5x13		3	3									
5	R663010	Serigrafia inferior (programador)		-	1									
6	R663062	Boton de mando (conmutadores)		2	2									
7	R663046	Junta (conmutadores)		2	2									
8	R663026	Conmutador de funciones		1	1									
9	R663063	Boton de mando (electronica)		2	2									
10	R663045	Junta (circuito impreso)		2	2									
11	R662810	Arandela guia		2	2									
12	Q151346	Tornillo avellanado M-3x5		4	4									
13	R662809	Guia boton de mando		2	2									
14	R663032	Pulsador		3	3									
15	R663025	Conmutador de funciones		1	1									
16	R663101	Fusible 1 A.		1	1									
17	R663050	Circuito impreso mando		1	1									
18	R663085	Circuito impreso control		1	1									
19	R663004	Circuito impreso programador		-	1									
20	R663036	Remache fijacion circuito		-	4									
21	Q152004	Tornillo aplastado M-5x13		2	2									
22	Q221342	Remache exagonal M-5		2	2									
23	R663036	Remache fijacion circuito		6	6									
24	R663035	Separador		4	4									
25	R663008	Soporte conmutadores		2	2									
26	Q151320	Tornillo alomado M-4x6		8	8									
27	R663005	Soporte circuitos impresos		1	1									
28	R663102	Conector de circuitos		1	1									

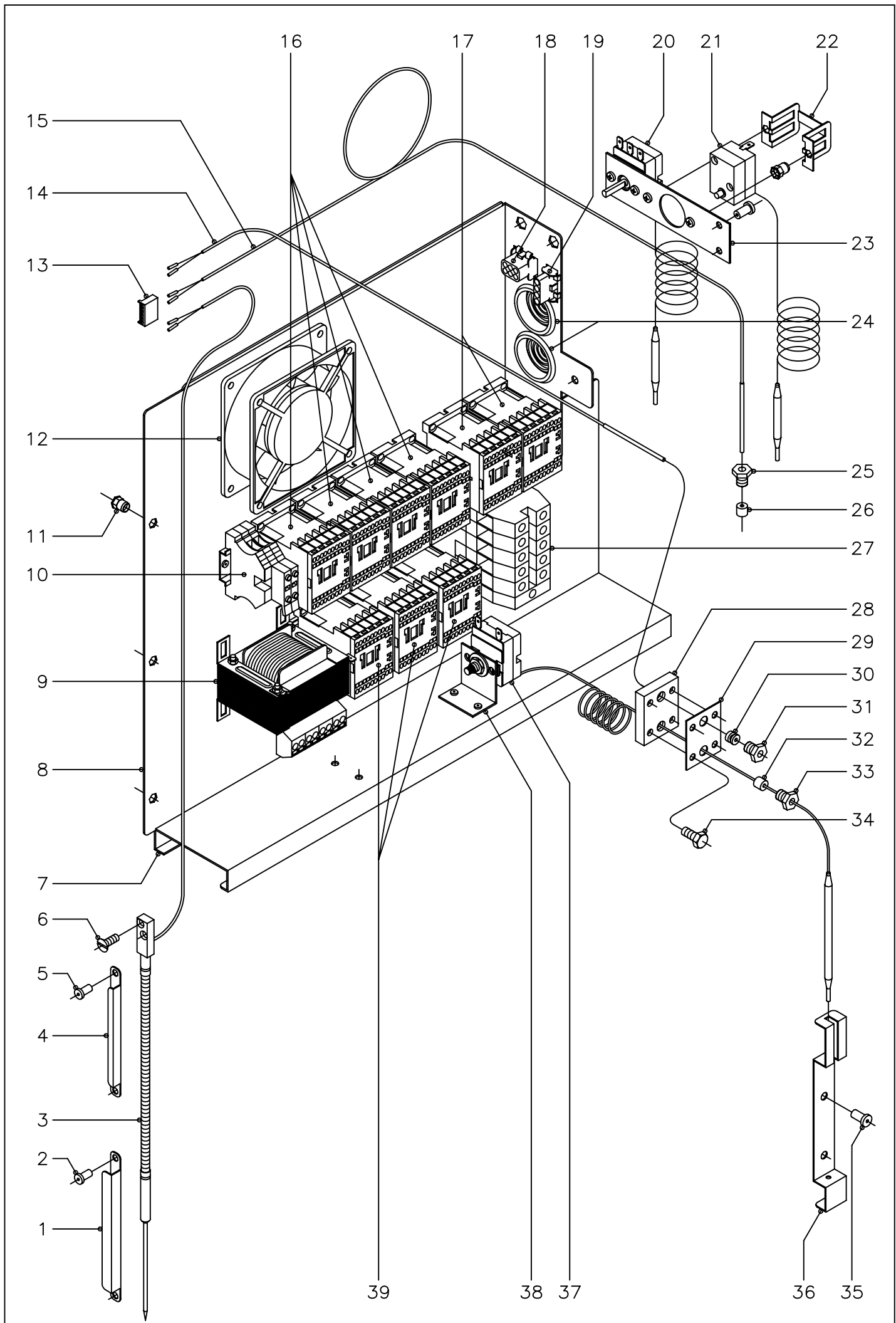

N plano C-1468	Firma 	Fecha 11-2003	Aparato CUADRO ELECTRICO HORNOS HME, HMP-20/11	Lamina 10	Fagor Industrial S.Coop. FAGOR Onate
-------------------	--	------------------	--	--------------	--

MOD.	HORNOS : HME, HMP-20/11	ZONA	CUADRO ELECTRICO	PLANO	C-1468
------	-------------------------	------	------------------	-------	--------

ITEM	CODIGO	DENOMINACION	TEXTO	HME-20/11	HMP-20/11									NOTAS
1	R672643	Soporte de sonda		1	1									
2	Q412002	Remache tubular Ø4x7,5		2	2									
3	R093019	Conjunto sonda nucleo		1	1									
4	R092633	Retenedor de sonda		2	2									
5	Q412002	Remache tubular Ø4x7,5		2	2									
6	Q042022	Tornillo avellanado M-4x15		2	2									
7	R663018	Contra guia panel cuadro		1	1									
	Q412002	Remache tubular Ø4x7,5		7	7									
8	R663081	Panel cuadro electrico		1	1									
9	R503005	Transformador		1	1									
10	R073005	Bornas portafusibles		2	2									
	P184011	Cartucho fusible 4 A.		2	2									
	Z263303	Tope final		1	1									
11	Q221342	Remache exagonal M-5		3	3									
12	Z103066	Ventilador		1	1									
13	R663093	Conector 6 vias		1	1									
14	R663090	Conjunto termopar L=1500		1	1									
15	R663089	Conjunto termopar L=2500		1	1									
16	Z203050	Contactador sirius 3RT-1016-2AP01		4	4									
	R693009	Guia contactor L=250		1	1									
17	Z203050	Contactador sirius 3RT-1016-2AP01		2	2									
	Z403016	Guia contactor L=100		1	1									
18	-	Conector hembra 6vias		1	1									
19	-	Conector hembra 4vias		1	1									
20	R343100	Termostato de condensacion		1	1									
	Q153111	Tornillo alomado M-4x8		2	2									
21	Z213014	Termostato Tecasa de seguridad		1	1									
22	Z203060	Amarre limitador Tecasa		1	1									
	Q221341	Remache exagonal M-4		2	2									

MOD.	HORNOS : HME, HMP-20/11	ZONA	CUADRO ELECTRICO	PLANO	C-1468
------	-------------------------	------	------------------	-------	--------

ITEM	CODIGO	DENOMINACION	TEXTO	HME-20/11	HMP-20/11									NOTAS
	Q153111	Tornillo alomado M-4x8		2	2									
23	R673061	Soporte amarre termostatos		1	1									
	Q412002	Remache tubular Ø4x7,5		2	2									
24	N103013	Pasacables		2	2									
25	R662629	Racord cierre sonda		1	1									
26	3712400	Tube-junta de silicona Ø8xØ3x20		1	1									
27	R263003	Borne gris fases 35		3	3									
	R673010	Borne azul neutro 35		1	1									
	Z103035	Borne verde-amarillo tierra 35		1	1									
	Z683096	Tope final 35		1	1									
	R663055	Guia contactor 120		1	1									
28	R662659	Pasamuros doble para sonda		1	1									
29	R692811	Junta pasamuros doble		1	1									
30	R662652	Bicono cierre sonda		1	1									
31	R662629	Racord cierre sonda		1	1									
32	R662662	Junta cierre bulbo limitador		1	1									
33	R662629	Racord cierre sonda		1	1									
34	Q012021	Tornillo exagonal M-4x10		4	4									
35	Q412002	Remache tubular Ø4x7,5		2	2									
36	R662630	Soporte de bulbo		1	1									
37	R243016	Termostato limitador temperatura		1	1									
38	R343039	Soporte de termostatos		2	2									
39	Z203050	Contactador sirius 3RT-1016-2AP01		3	3									
	Z103084	Guia contactor 138		1	1									

MOD.		HORNOS : HMM, HME, HMP-20/11		ZONA		VARIOS					PLANO	
ITEM	CODIGO	DENOMINACION	TEXTO	HMM-20/11	HME-20/11	HMP-20/11	HMM-20/11 UL	MFHMM-20/11				NOTAS
	R746501	Folleto de instrucciones		1	-	-	-	-				
	R666501	Folleto de instrucciones		-	1	1	-	-				
	R696516	Folleto de instrucciones		-	-	-	1	-				
	R746503	Folleto de instrucciones		-	-	-	-	1				
	R503003	Esquema electrico adhesivo		1	-	-	-	-				Plano HC-72273
	R143019	Esquema electrico adhesivo		-	1	1	-	-				Plano HC-74199
	R753025	Esquema electrico adhesivo		-	-	-	1	-				Plano HC-74750
	R753023	Esquema electrico adhesivo		-	-	-	-	1				Plano HC-74740
	R503004	Esquema electrico de montaje		1	-	-	1	1				Plano HD-12493
	R143018	Esquema electrico de montaje		-	1	1	-	-				Plano HD-12681
	R503009	Instalacion electrica HMM		1	-	-	-	-				
	R143017	Instalacion electrica HME, HMP		-	1	1	-	-				
	R503008	Instalacion electrica HMM, (UL)		-	-	-	1	1				
	R143005	Cableado fuerza conveccion		1	1	1	-	-				
	R143015	Cableado fuerza conveccion		-	-	-	1	1				
	R673013	Instalacion fuerza cuadro electrico		1	1	1	-	-				
	R753020	Instalacion fuerza cuadro electrico		-	-	-	1	1				
	R663095	Cableado luz interior		1	1	1	1	1				
	R093021	Cableado luz puerta		1	1	1	-	-				
	R093011	Cableado luz puerta		-	-	-	1	1				
	R093004	Cable auxiliar prolongador		2	2	2	-	-				
	R093012	Cable auxiliar prolongador		-	-	-	2	2				
	3713900	Funda roja-negra Ø6,4x500		1	1	1	1	1				
	R143004	Cableado fuerza vapor		1	1	1	-	-				
	R143014	Cableado fuerza vapor		-	-	-	1	1				
	R143009	Instalacion doble potencia		1	1	1	-	-				

3N~50/60Hz 380/415V

MODELO HMM-20/11 HMM-20/21

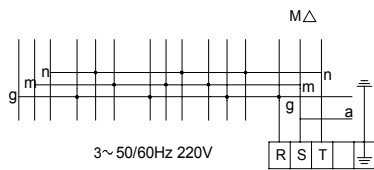
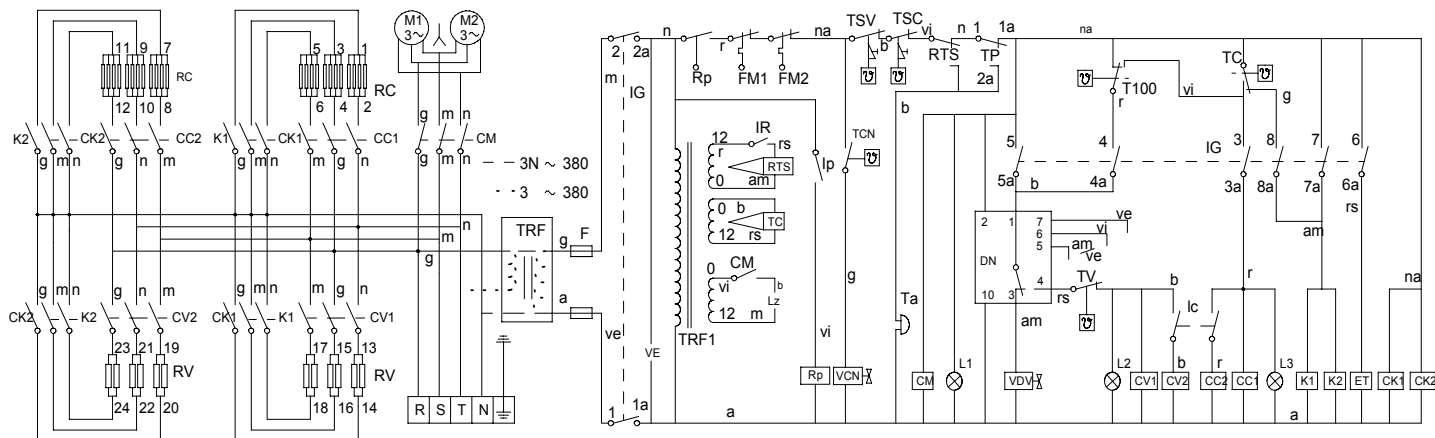

am/ve = amarillo/verde-yellow/green-jaune/vert
 am = amarillo-yellow-jaune
 a = azul-blue-bleu
 b = blanco-white-blanc
 g = gris-grey-gris
 ve = verde-green-vert

na = naranja-orange-orange
 r = rojo-red-rouge
 m = marron-brown-marron
 n = negro-black-noir
 rs = rosa-pink-rose
 vi = violeta-violet-violette

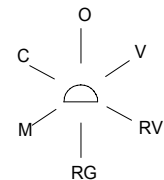

Mode	1 1a	2 2a	3 3a	4 4a-5a	5-6-7 6a-7a-8a	8
OFF						
VAPOR	X	X		X		X
Reg. Vapor	X	X		X		X
REGENERAC.	X	X	X	X		X
MIXTO	X	X	X	X		X
CONVECCION	X	X	X		X	X

R-503003 HC-72273

IP = Interruptor puerta
 IG = Interruptor general
 F = Fusible
 CM = Contactor motor
 VDV = Electroválvula calderín
 DN = Detector de nivel
 FM1, FM2 = Térmico motor
 TSV = Termostato seguridad vapor
 TSC = Termostato seguridad cámara
 LZ = Luz interior
 IR = Selector regulador sonda nucleo
 RTS = Regulador temperatura sonda nucleo
 RV = Resistencias vapor
 VE = Ventilador cuadro eléctrico
 Ta = Timbre avisador
 RP = Relé puerta

ET = Electroimán de apertura de tiro
 Ic = Selector de potencia
 VCN = Electroválvula de condensación de vapor
 TC = Termostato cámara
 T100 = Termostato fijo 100°C
 TV = Termostato vapor
 M1, M2 = Motor
 CC1, CC2 = Contactor resistencia cámara
 CV1, CV2 = Contactor resistencia vapor
 CK1, CK2, K1, K2 = Relé resistencias
 TCN = Termostato de condensación vapor
 RC = Resistencias cámara
 TRF, TRF1 = Transformador
 L1 = Lámpara de funcionamiento
 L2 = Lámpara de calentamiento vapor
 L3 = Lámpara de calentamiento cámara

ESQUEMA TEORICO ADHESIVO		R-503003			
Nº	Pieza	Cant.	Material	Nº Clasificación	Acabado
Nº	Modificación		Propuesta de	Fecha	Tolerancias generales
1	Modificar TSV, TSC y TCN		Maillo	2/10/96	<5± : 50-100± : 5-25± : > 100± 25-50± : <X±
2	Modif. general (pasar a fabric. interior)		Plazaola	29/4/97	
3	Eliminar filtro interferencias		Maillo	25/4/98	
4	Introducir Rp		Maillo	25/2/02	
Dibujado		Firma	Fecha	Mecanizado superficial	
Proyectado		KONTXI	11/3/98	FAGOR	
Comprobado				Fagor Industrial, Koop, Elk, Mugatua	
Escala		Horno Mixto HMM			Plano numero
					HC-72273 -4
					Sustituye al Nº
					Sustituido por

Plano hau ez dateke erabili ez berrizta gure baimenitz gabe

3N~50/60Hz 380/415V

MODELO HME-20/11 HMP-20/11

HME-20/21 HMP-20/21

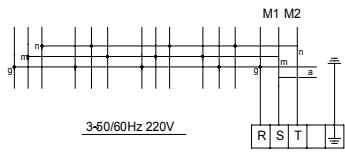
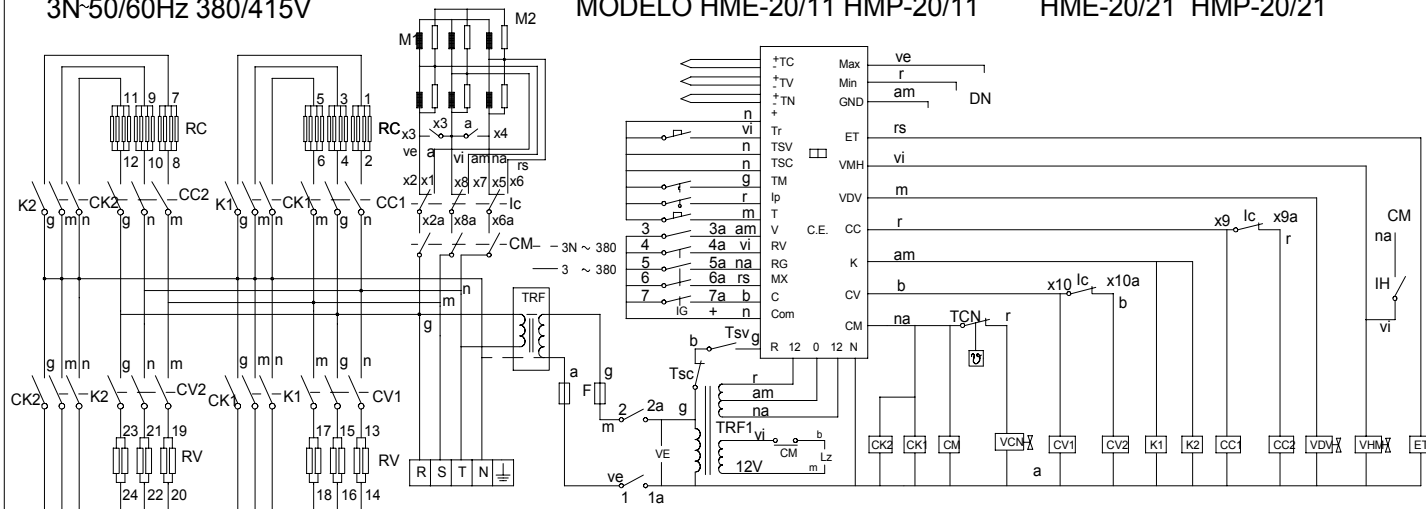

- IP = Door's switch
- IG = General switch
- F = Fuse
- CM = Motor's relay
- VDV = Steamer's solenoid
- DN = Water level control
- TM = Motor's thermal protection
- TSV = Steamer's security thermostat
- TSC = Convection's security thermostat
- LZ = Indoor light
- VHM = Humidity water solenoid
- CE = Electronic main control
- RV = Steamer elements
- VE = Control panel's fan
- Tr = Chimney selector
- TRF, TRF1 = Transformer
- ET = Chimney solenoid
- Ic = Power reduction switch
- VCN = Steamer condenser solenoid
- TC = Convection probe
- TN = Food probe
- M1, M2 = Motor
- CC1, CC2 = Heating air relays
- CV1, CV2 = Heating water relays
- CK1, CK2, K1, K2 = Elements relays
- TCN = Steam condenser thermostat
- IH = Humidity switch
- T = Timer or Food probe selector
- RC = Heating element

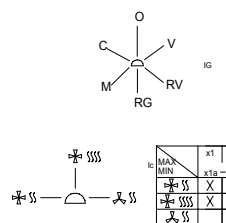

Mode	1	2	3	4	5	6	7
	1a	2a	3a	4a	5a	6a	7a
OFF							
VAPOR	X	X	X				
REG. VAPOR	X	X	X				
REGENERAC.	X	X			X		
MIXTO	X	X				X	
CONVECCION	X	X					X

IC	MIN	x1	x2 - x3	x4 - x5	x6	x7	x8	x9	x10
		x1a - x2a	x3a - x4a	x5a - x6a	x7a - x8a	x9a	x10a		
MIN	X	X	X	X	X	X	X	X	X
MAX	X	X	X	X	X	X	X	X	X
VE	X	X	X	X	X	X	X	X	X

- am/ve = amarillo-verde-yellow-green-jaune-vert
- am = amarillo-yellow-jaune
- a = azul-blue-bleu
- b = blanco-white-blanc
- g = gris-grey -gris
- ve = verde-green-vert
- na = naranja-orange-orange
- r = rojo-red-rouge
- m = marron-brown-marron
- n = negro-black-noir
- rs = rosa-pink-rose
- vi = violeta-violet-violette

R-143019

HC-74199

		3~50/60Hz 220V			
ESQUEMA TEORICO ADHESIVO		3N~50/60Hz 380/415V		R-143019	
Nº	Pieza	Cant.	Material	Nº Clasificacion	Acabado
Nº	Modificacion	Propuesta de		Fecha	Tolerancias generales
				<5± : 50-100± : 5-25± : > 100± : 25-50± : <± :	
Dibujado	Firma	Fecha	FAGOR		
Proyectado	Iraxte	17/3/99			
Comprobado					
Escala	Fagor Industrial, Koop, Elk, Mugatua			Mecanizado superficial	
Horno MIXTO HME HMP				Plano numero	
				HC-74199	
Plano hau ez dateke erabili ez berrizta gure baimenitz gabe				Sustituye al Nº hc-72270	
				Sustituido por	

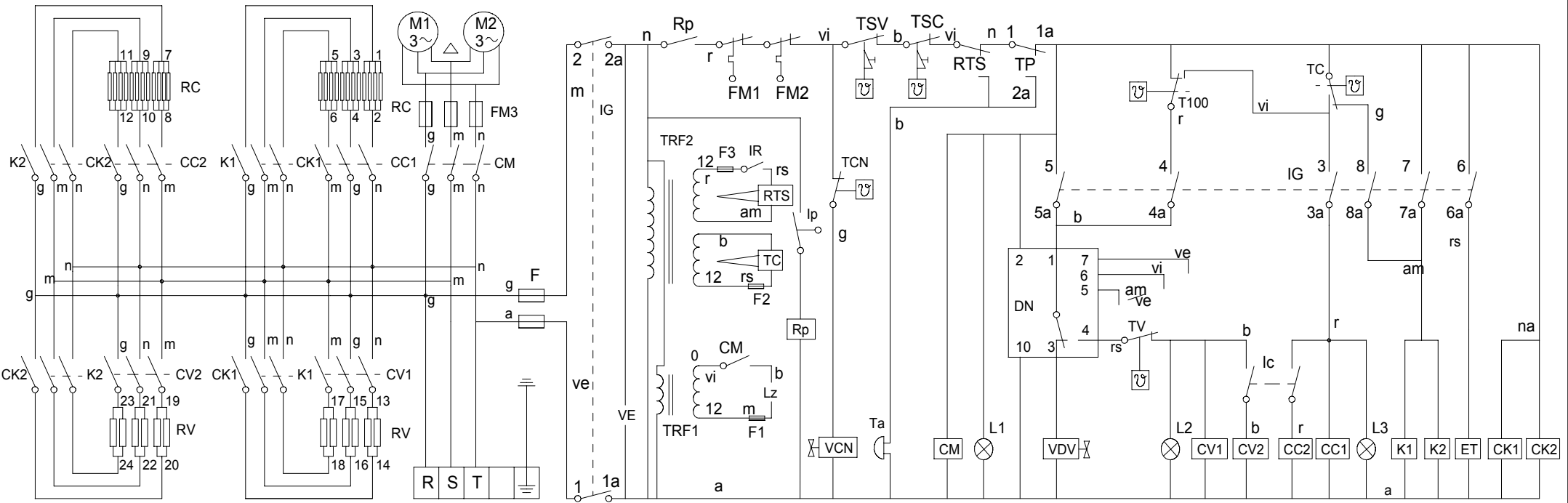

- FM3 = Motor fuse
- IP = Door's switch
- IG = General switch
- F = Fuse
- CM = Motor's relay
- VDV = Steamer's solenoid
- DN = Water level control
- FM1, FM2 = Motor's thermal protection
- TSV = Steamer's security thermostat
- TSC = Convection's security thermostat
- LZ = Indoor light
- IR = Probe selector
- RTS = Probe controller
- RV = Steamer elements

- ET = Chimney solenoid
- Ic = Power reduction switch
- VCN = Steamer condenser solenoid
- TC = Convection thermostat
- T100 = 100 °C thermostat
- TV = Steamer's thermostat
- M1, M2 = Motor
- CC1, CC2 = Heating air relays
- CV1, CV2 = Heating water relays
- CK1, CK2, K1, K2 = Elements relays
- TCN = Steam condenser thermostat
- RC = Heating element
- TRF2= Transformer (Electronic thermostat)

- VE = Control panel's fan
- Ta = Alarm
- TP = Manual Timer
- F1, F2, F3 = Transformer fuse
- TRF1 = Transformer (Indoor light)
- L1 = Pilot lamp (on/off)
- L2 = Pilot lamp (Heating water)
- L3 = Pilot lamp (Heating air)
- Rp = Door's Relay

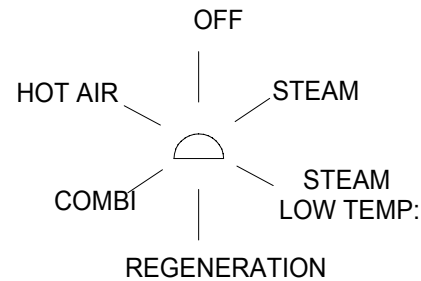

Mode \	1 1a	2 2a	3 3a	4 4a	5 5a	6 6a	7 7a	8 8a
OFF								
STEAM	X	X			X		X	
STEAM LOW TEMP	X	X		X			X	
REGENERATION	X	X	X	X				X
COMBI	X	X	X	X				
HOT AIR	X	X	X			X	X	

- am/ve = amarillo/verde-yellow/green-jaune/vert
- am = amarillo-yellow-jaune
- a = azul-blue-bleu
- b = blanco-white-blanc
- g = gris-grey -gris
- ve = verde-green-vert

- na = naranja-orange-orange
- r = rojo-red-rouge
- m = marron-brown-marron
- n = negro-black-noir
- rs = rosa-pink-rose
- vi = violeta-violet-violette

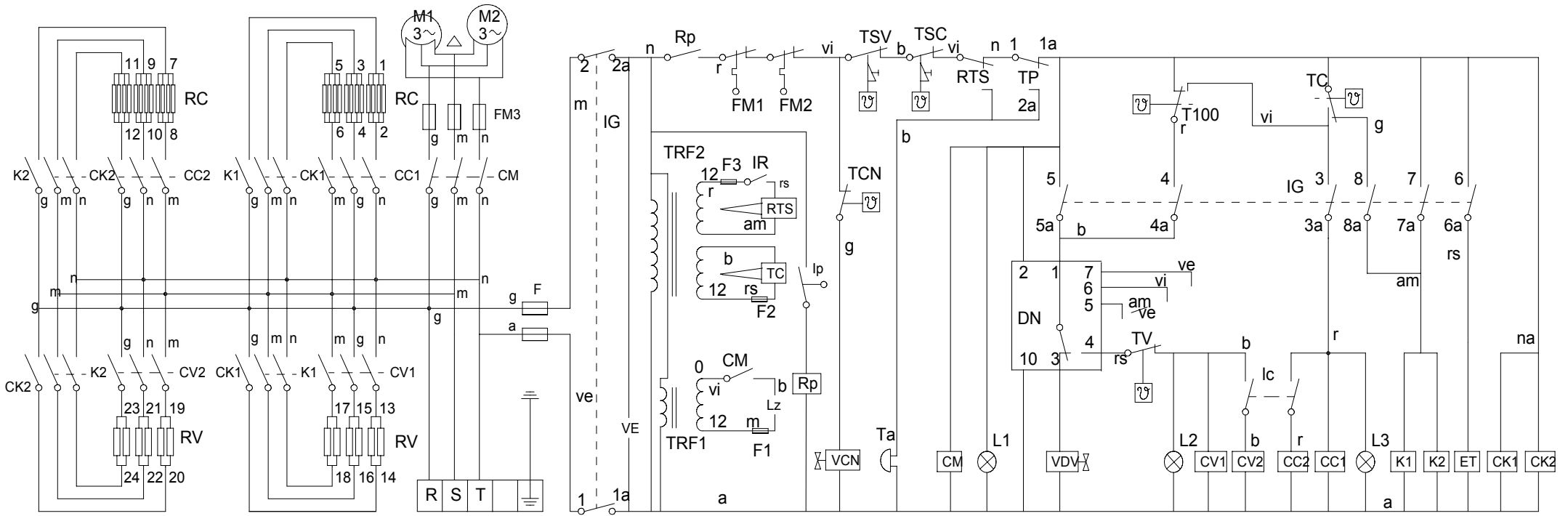

FM3 = Motor fuse

IP = Door's switch

IG = General switch

F = Fuse

CM = Motor's relay

VDV = Steamer's solenoid

DN = Water level control

FM1, FM2 = Motor's thermal protection

TSV = Steamer's security thermostat

TSC = Convection's security thermostat

LZ = Indoor light

IR = Probe selector

RTS = Probe controller

RV = Steamer elements

ET = Chimney solenoid

Ic = Power reduction switch

VCN = Steamer condenser solenoid

TC = Convection thermostat

T100 = 100 °C thermostat

TV = Steamer's thermostat

M1, M2 = Motor

CC1, CC2 = Heating air relays

CV1, CV2 = Heating water relays

CK1, CK2, K1, K2 = Elements relays

TCN = Steam condenser thermostat

RC = Heating element

TRF2= Transformer (Electronic thermostat)

VE = Control panel's fan

Ta = Alarm

Tp = Manual Timer

F1, F2, F3 = Transformer fuse

TRF1 = Transformer (Indoor light)

L1 = Pilot lamp (on/off)

L2 = Pilot lamp (Heating water)

L3 = Pilot lamp (Heating air)

Rp = Door's relay

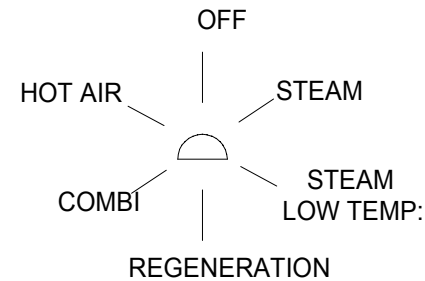

Mode \	1 1a	2 2a	3 3a	4 4a-5a	5-6 6a	7-8 7a-8a	8
OFF							
STEAM	X	X			X		X
STEAM LOW TEMP	X	X		X			X
REGENERATION	X	X	X	X			X
COMBI	X	X	X	X			
HOT AIR	X	X	X			X	X

am/ve = amarillo/verde-yellow/green-jaune/vert
 am = amarillo-yellow-jaune
 a = azul-blue-bleu
 b = blanco-white-blanc
 g = gris-grey -gris
 ve = verde-green-vert

na = naranja-orange-orange
 r = rojo-red-rouge
 m = marron-brown-marron
 n = negro-black-noir
 rs = rosa-pink-rose
 vi = violeta-violet-violette

