

**Hornos Mixtos
Fours Mixtes
Combi Ovens
HeiBluftdämpfer
Forno Misti**

Modelos:

HMM-20/21

HME-20/21

HMP-20/21

VECM-20/21

VECE-20/21

VECP-20/21

HMM-20/21 UL

Noviembre 2003 November



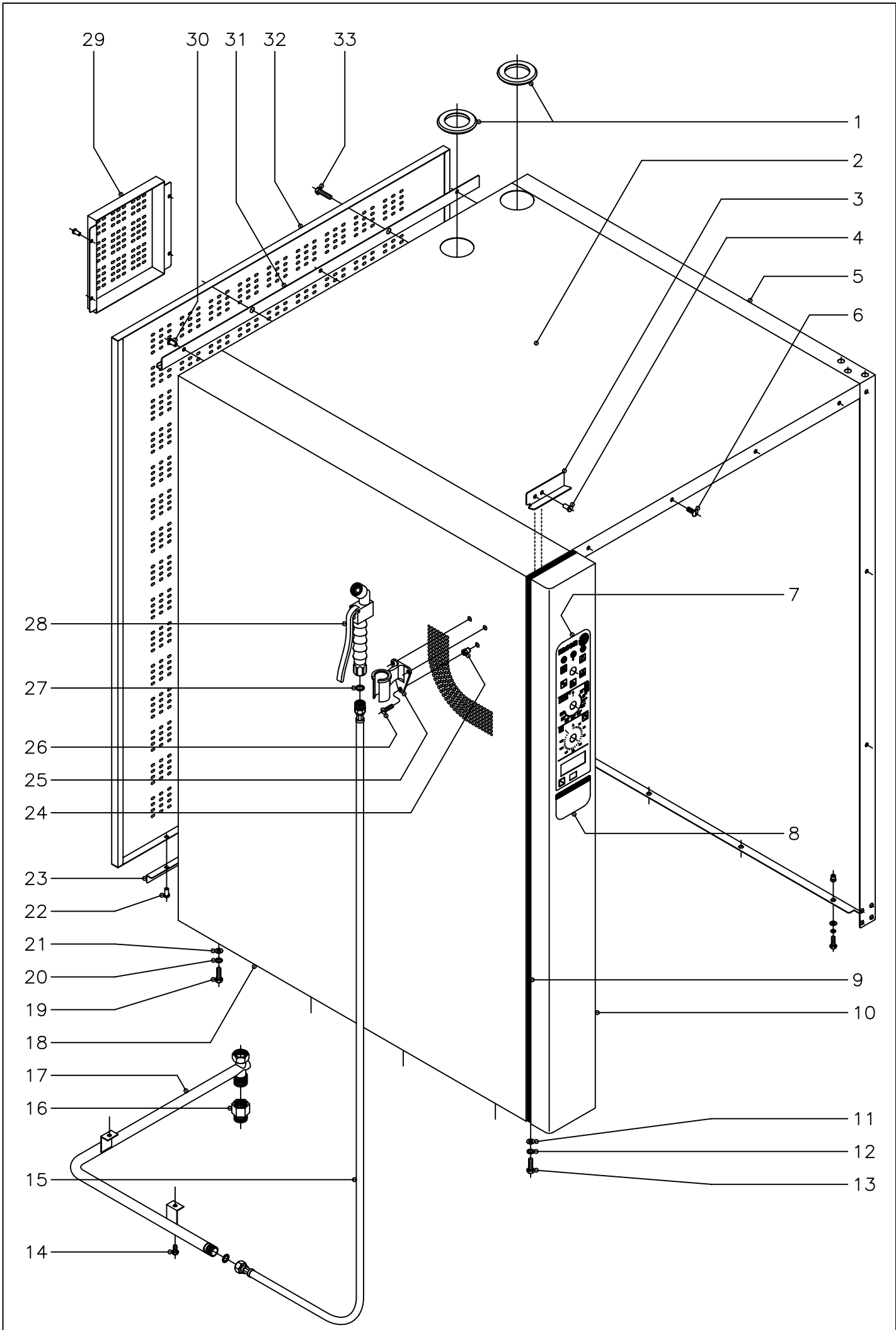

Fagor Industrial

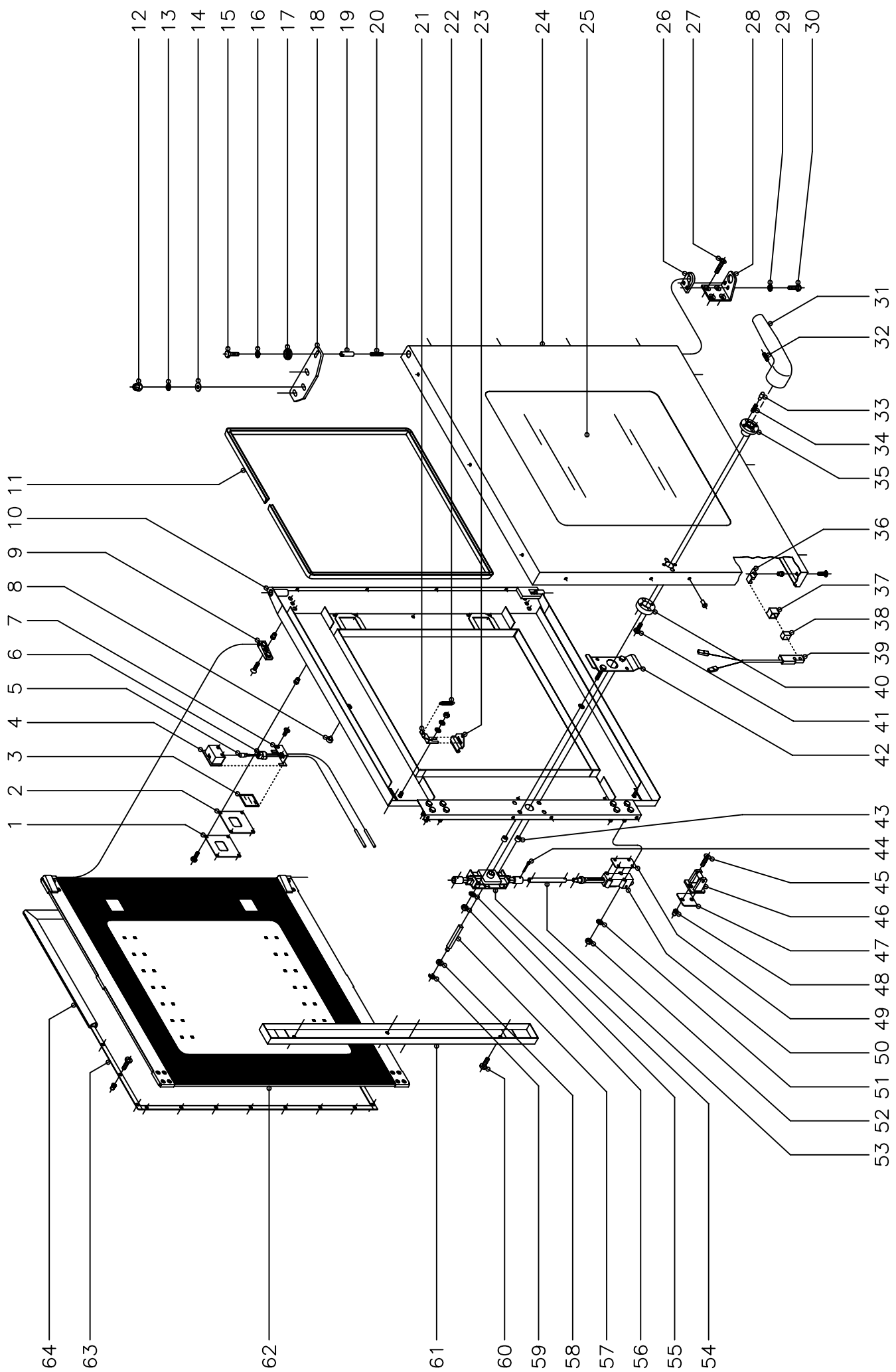

N plano	Firma	Fecha	Aparato	MUEBLE	Lamina	Fagor Industrial S.Coop. FAGOR
C-1469		11-2003	HORNOS HMM, HME, HMP-20/21		1	Oñate

MOD.		HORNOS : HMM, HME, HMP-20/21		ZONA	MUEBLE								PLANO	C-1469	
ITEM	CODIGO	DENOMINACION	TEXTO	HMM-20/21	HMM-2-20/11	HME-20/21	HME-2-20/11	HMP-20/21	HMP-2-20/11	HMM-20/21UL					NOTAS
1	R662813	Pasamuros chimenea		2		2		2		2					
2	R142832	Panel superior		1		1		1		1					
	Q221343	Remache exagonal M-6		4		4		4		4					Amarre panel superior a laterales
	Q232040	Arandela plana A-6		4		4		4		4					Amarre panel superior a laterales
	Q262040	Arandela muelle A-6		4		4		4		4					Amarre panel superior a laterales
	Q012042	Tornillo exagonal M-6x15		4		4		4		4					Amarre panel superior a laterales
3	R662811	Fijacion portamandos		1		1		1		1					
4	Q412002	Remache tubular Ø 4x7,5		2		2		2		2					
5	R142831	Panel lateral derecho		1		1		1		1					
6	Q152017	Tornillo amarre M-6x13		7		7		7		7					
7	R743012	Serigrafia superior (controlador)		1		-		-		-					
7	R673000	Serigrafia superior (controlador)		-		1		1		-					
7	R743070	Serigrafia superior (controlador)		-		-		-		1					
8	R693000	Serigrafia inferior (conmutador)		1		-		-		1					
8	R663014	Serigrafia inferior (neutra)		-		1		-		-					
8	R663010	Serigrafia inferior (programador)		-		-		1		-					
9	3715400	Junta panel portamandos L=130		1		1		1		1					
9	3715400	Junta panel portamandos L=1400		2		2		2		2					
10	R772805	Panel portamandos		1		-		-		1					
10	R092837	Panel portamandos		-		1		1		-					
11	Q232040	Arandela plana A-6		2		2		2		2					
12	Q262040	Arandela muelle A-6		2		2		2		2					
13	Q012042	Tornillo exagonal M-6x15		2		2		2		2					
14	Q012042	Tornillo exagonal M-6x15		*		1		1		1					* Opcional bajo pedido
15	R095006	Flexible de ducha		*		1		1		1					* Opcional bajo pedido
16	T125033	Adaptador a rosca UL		-		-		-		1					
17	R145041	Suplemento ducha		*		1		1		1					* Opcional bajo pedido
18	R142807	Panel lateral izquierdo		1		1		1		1					
19	Q012042	Tornillo exagonal M-6x15		8		8		8		8					



N plano C-1470	Firma 	Fecha 11-2003	Aparato HORNOS HMM, HME, HMP-20/21	PUERTA Lamina 2	Fagor Industrial S.Coop. FAGOR Onate
-------------------	--	------------------	---------------------------------------	-----------------------	--

MOD.	HORNOS : HMM, HME, HMP-20/21	ZONA	PUERTA						PLANO	C-1470
------	------------------------------	------	--------	--	--	--	--	--	-------	--------

ITEM	CODIGO	DENOMINACION	TEXTO	HMM-20/21	HMM-2-20/11	HME-20/21	HME-2-20/11	HMP-20/21	HMP-2-20/11	HMM-20/21UL							NOTAS
	1100002598	KIT Puerta completa 20/21		1		1		1		1							
1	R670608	Tapa cierre lampara		2		2		2		2							
	Q152004	Tornillo alomado M-5x13		8		8		8		8							
	Q222011	Remache exagonal M-5		8		8		8		8							
2	R670609	Junta cierre lampara		2		2		2		2							
3	R670618	Cristal de lampara		2		2		2		2							
4	R670610	Deflector de lampara		2		2		2		2							
5	R663013	Lampara 10 W. 12 V.		2		2		2		2							
6	R663058	Portalamparas		2		2		2		2							
7	R670611	Suplemento deflector		2		2		2		2							
	Q042031	Tornillo avellanado M-5x10		4		4		4		4							
8	R670617	Tope cristal interior		8		8		8		8							
9	R670615	Base de bisagra		2		2		2		2							
	Q042032	Tornillo avellanado M-5x15		2		2		2		2							
	Q222011	Remache exagonal M-5		2		2		2		2							
10	R140500	Contrapuerta completa 20/21		1		1		1		1							
11	3715200	Junta cristal L=3400		1		1		1		1							
12	Q212051	Tuerca sombrerete M-8		3		3		3		3							
13	Q242050	Arandela abanico A-8		3		3		3		3							
14	Q302025	Arandela plana Ø8,4xØ20x1,5		3		3		3		3							
15	Q012042	Tornillo exagonal M-6x15		1		1		1		1							
16	Q242040	Arandela abanico A-6		1		1		1		1							
17	R662807	Arandela amarre puerta		1		1		1		1							
18	T130500	Bisagra superior		1		1		1		1							
19	R660534	Eje superior		1		1		1		1							
20	Z850519	Resorte		1		1		1		1							
21	R670612	Base de pestillo		2		2		2		2							
	Q302022	Arandela plana Ø16xØ6x1,2		2		2		2		2							

MOD.	HORNOS : HMM, HME, HMP-20/21	ZONA	PUERTA						PLANO	C-1470
------	------------------------------	------	--------	--	--	--	--	--	-------	--------

ITEM	CODIGO	DENOMINACION	TEXTO	HMM-20/21	HMM-2-20/11	HME-20/21	HME-2-20/11	HMP-20/21	HMP-2-20/11	HMM-20/21UL							NOTAS
	Q242040	Arandela abanico A-6		2		2		2		2							
	Q162040	Tuerca exagonal M-6		2		2		2		2							
22	R660605	Muelle tensor pestillo		2		2		2		2							
23	R670613	Pestillo sujecion cristal interior		2		2		2		2							
24	R140600	Panel puerta 20/21		1		1		1		1							
	Q412002	Remache tubular Ø4x7,5		16		16		16		16							
25	R140604	Cristal exterior 20/21		1		1		1		1							
26	R660549	Guia eje inferior		1		1		1		1							
27	Q062040	Tornillo avellanado M-6x16		4		4		4		4							
28	R660551	Bisagra inferior		1		1		1		1							
29	Q242040	Arandela abanico A-6		2		2		2		2							
30	Q012041	Tornillo exagonal M-6x10		2		2		2		2							
31	T130502	Manilla		1		1		1		1							
32	Q132042	Varilla roscada M-6x15		1		1		1		1							
33	T130507	Piton enganche		2		2		2		2							
34	T130506	Resorte		2		2		2		2							
35	T130515	Guia manilla		1		1		1		1							
36	T130513	Soporte iman		1		1		1		1							
37	Z200507	Protector iman		1		1		1		1							
38	Z200506	Iman		1		1		1		1							
39	Z100522	Interruptor magnetico		1		1		1		1							
40	T130514	Soporte resortes		1		1		1		1							
41	Q032032	Tornillo alomado M-5x15		2		2		2		2							
42	T130511	Suplemento fijacion cerradura		1		1		1		1							
43	Z608410	Casquillo		2		2		2		2							
44	Q352001	Pasador de aletas Ø2x15		4		4		4		4							
45	Q042043	Tornillo avellanado M-6x20		4		4		4		4							
46	R260545	Enganche		2		2		2		2							
47	R660538	Calzo de enganche		6		6		6		6							

MOD.		HORNOS : HMM, HME, HMP-20/21		ZONA		PUERTA				PLANO		C-1470		
ITEM	CODIGO	DENOMINACION	TEXTO	HMM-20/21	HMM-2-20/11	HME-20/21	HME-2-20/11	HMP-20/21	HMP-2-20/11	HMM-20/21UL				NOTAS
48	Q221343	Remache exagonal M-6		4		4		4		4				
49	T080503	Suplemento elemento cierre		6		6		6		6				
50	T080504	Elemento de cierre		2		2		2		2				
51	Q262040	Arandela muelle A-6		8		8		8		8				
52	Q162040	Tuerca exagonal M-6		8		8		8		8				
53	R090514	tubo alargadera		2		2		2		2				
54	T130509	Mecanismo de cierre		1		1		1		1				
55	Q262040	Arandela muelle A-6		2		2		2		2				
56	Q162040	Tuerca exagonal M-6		2		2		2		2				
57	T130508	Eje de manilla		1		1		1		1				
58	T130505	Casquillo		1		1		1		1				
59	Q271033	Arandela de seguridad Ø6		1		1		1		1				
60	Q032031	Tornillo alomado M-5x10		2		2		2		2				
60	Q032021	Tornillo alomado M-4x10		2		2		2		2				
61	T140502	Tapa cierre puerta		1		1		1		1				
62	1100002810	KIT Cristal interior completo 20/21		1		1		1		1				
63	R140507	Fijacion junta completa 20/21		1		1		1		1				
	Q033021	Tornillo alomado M-4x10 (laton)		40		40		40		40				
	Q222041	Remache exagonal M-4 inox.		40		40		40		40				
64	R140506	Junta de puerta 20/21		1		1		1		1				

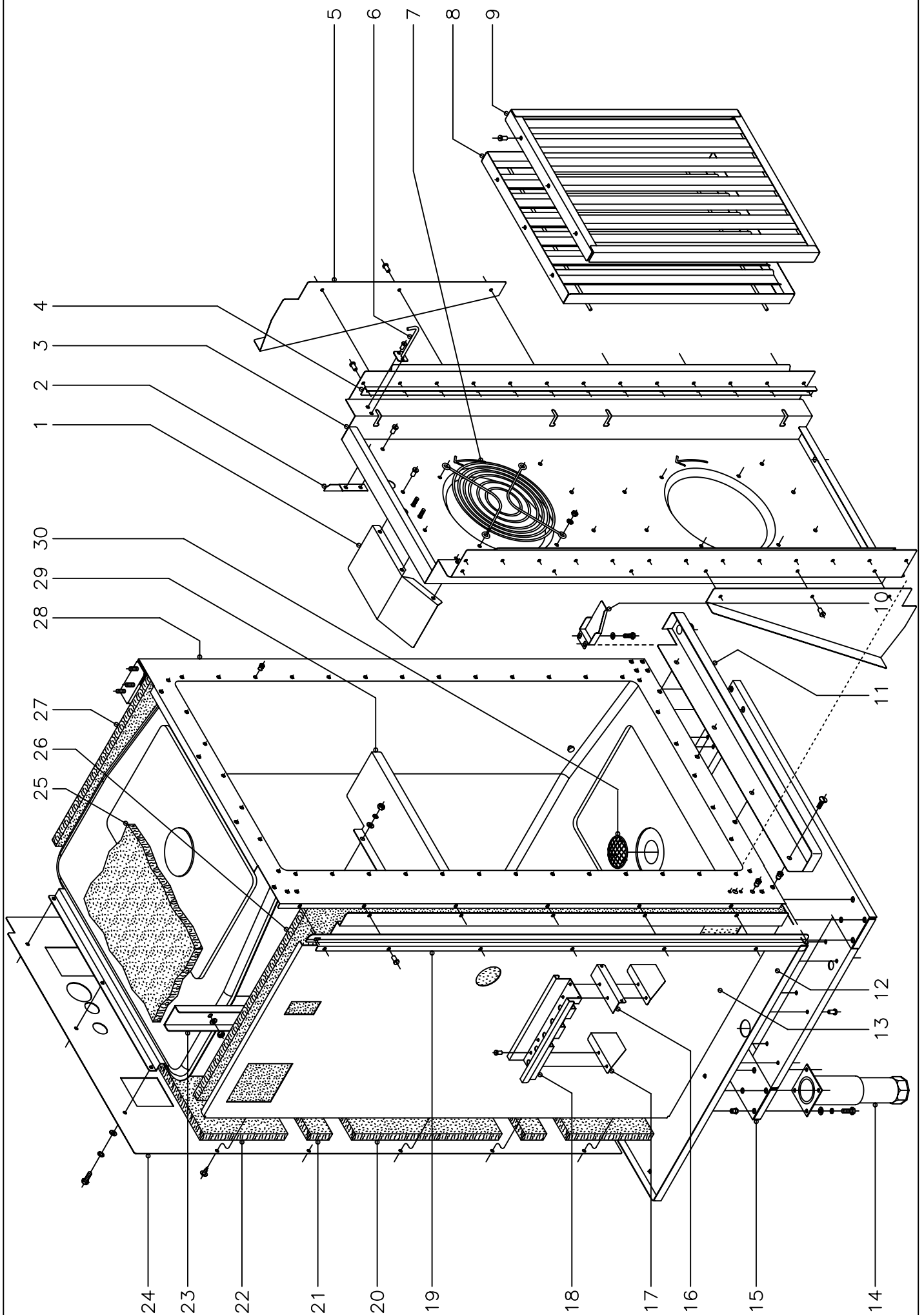

N plano C-1471	Firma 	Fecha 11-2003	Aparato MUEBLE INTERIOR HORNOS HMM, HME, HMP-20/21	Lamina 3	Fagor Industrial S.Coop. FAGOR  Ofate
-------------------	--	------------------	--	-------------	--



MOD.	HORNOS : HMM, HME, HMP-20/21	ZONA	MUEBLE INTERIOR	PLANO	C-1471
------	------------------------------	------	-----------------	-------	--------

ITEM	CODIGO	DENOMINACION	TEXTO	HMM-20/21	HMM-2-20/11	HME-20/21	HME-2-20/11	HMP-20/21	HMP-2-20/11	HMM-20/21UL							NOTAS
1	R682632	Deflector turbina		4		4		4		4							
	Q412002	Remache tubular Ø 4x7,5		12		12		12		12							
2	R292647	Escuadra sujecion cubreventilador		2		2		2		2							
	Q412002	Remache tubular Ø 4x7,5		4		4		4		4							
3	R142603	Cubre ventilador		1		1		1		1							
4	R092616	Tope cubreventilador		2		2		2		2							
	Q412002	Remache tubular Ø 4x7,5		26		26		26		26							
5	R732619	Aleron lateral		4		4		4		4							
	Q412002	Remache tubular Ø 4x7,5		12		12		12		12							
6	R142615	Fijacion portabandejas		2		2		2		2							
	Q412002	Remache tubular Ø 4x7,5		4		4		4		4							
7	R662661	Proteccion de turbina		-		-		-		1							
	Q032021	Tornillo alomado M-4x10		-		-		-		4							
	Q242020	Arandela abanico A-4		-		-		-		4							
	Q162020	Tuerca exagonal M-4		-		-		-		4							
8	R092621	Posterior de filtro		2		2		2		2							
9	R092618	Anterior de filtro		2		2		2		2							
	Q412002	Remache tubular Ø 4x7,5		12		12		12		12							
10	R662800	Cubrecables		1		1		1		1							
	Q221342	Remache exagonal M-5		2		2		2		2							
	Q232030	Arandela plana A-5		2		2		2		2							
	Q012031	Tornillo exagonal M-5x10		2		2		2		2							
11	T142820	Recogeaguas		1		1		1		1							
	Q221343	Remache exagonal M-6		4		4		4		4							
	Q152017	Tornillo amarre M-6x13		4		4		4		4							
12	R142830	Base exterior de horno		1		1		1		1							
13	T152604	Soporte lateral aislante		1		1		1		1							
14	R092830	Pata regulable		4		4		4		4							
	Q012043	Tornillo exagonal M-6x20		16		16		16		16							

MOD.	HORNOS : HMM, HME, HMP-20/21	ZONA	MUEBLE INTERIOR	PLANO	C-1471
------	------------------------------	------	-----------------	-------	--------

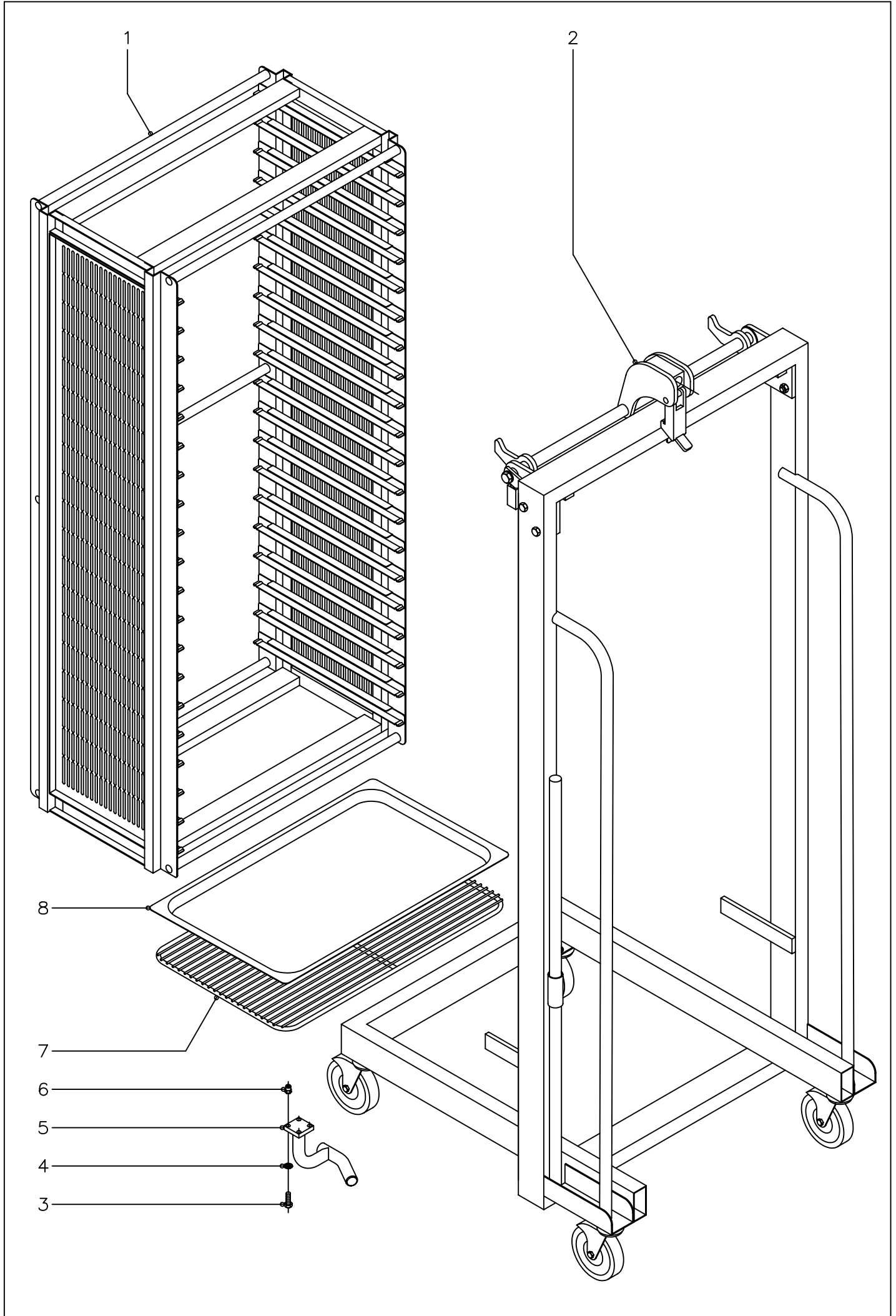
ITEM	CODIGO	DENOMINACION	TEXTO	HMM-20/21	HMM-2-20/11	HME-20/21	HME-2-20/11	HMP-20/21	HMP-2-20/11	HMM-20/21UL							NOTAS
	Q262040	Arandela muelle A-6		16		16		16		16							
	Q232040	Arandela plana A-6		16		16		16		16							
	Q221343	Remache exagonal M-6		16		16		16		16							
15	T152801	Refuerzo de apoyos		1		1		1		1							
	Q412002	Remache tubular Ø 4x7,5		24		24		24		24							
16	R092611	Fijacion a panel lateral		1		1		1		1							
17	R092610	Refuerzo base de cuadro		2		2		2		2							
18	R342821	Guia cuadro electrico		1		1		1		1							
	Q411304	Remache avibulb Ø 4,8		10		10		10		10							
19	R092662	Protector de portamandos		1		1		1		1							
	Q412002	Remache tubular Ø 4x7,5		6		6		6		6							
20	U675605	Aislante central 740x380x20		1		1		1		1							
21	R662616	Aislante entre refuerzos 560x60x20		8		8		8		8							
22	R032625	Aislante supe. e inferi. 760x230x20		2		2		2		2							
23	R142613	Refuerzo vertical		2		2		2		2							
	Q232040	Arandela plana A-6		12		12		12		12							
	Q162040	Tuerca exagonal M-6		12		12		12		12							
24	R142601	Soporte aislante posterior		1		1		1		1							
	Q151301	Tornillo alomado		5		5		5		5							
	Q012042	Tornillo exagonal M-6x15		15		15		15		15							
	Q262040	Arandela muelle A-6		15		15		15		15							
	Q232040	Arandela plana A-6		15		15		15		15							
25	R682623	Aislante base y techo 860x790x20		5		5		5		5							
26	R142608	Aislante lateral 1370x860x20		3		3		3		3							
27	R142608	Aislante lateral 1370x860x20		2		2		2		2							
28	R142625	Cuerpo interior horno		1		1		1		1							
29	R142609	Separador central		1		1		1		1							
	Q232040	Arandela plana A-6		2		2		2		2							
	Q262040	Arandela muelle A-6		2		2		2		2							



N plano C-1472	Firma 	Fecha 11-2003	Aparato CARRO Y ESTRUCTURA PORTABANDEJAS HORNOS HMM, HME, HMP-20/21	Lamina 4	Fagor Industrial S.Coop. FAGOR  Oñate
-------------------	--	------------------	---	-------------	--

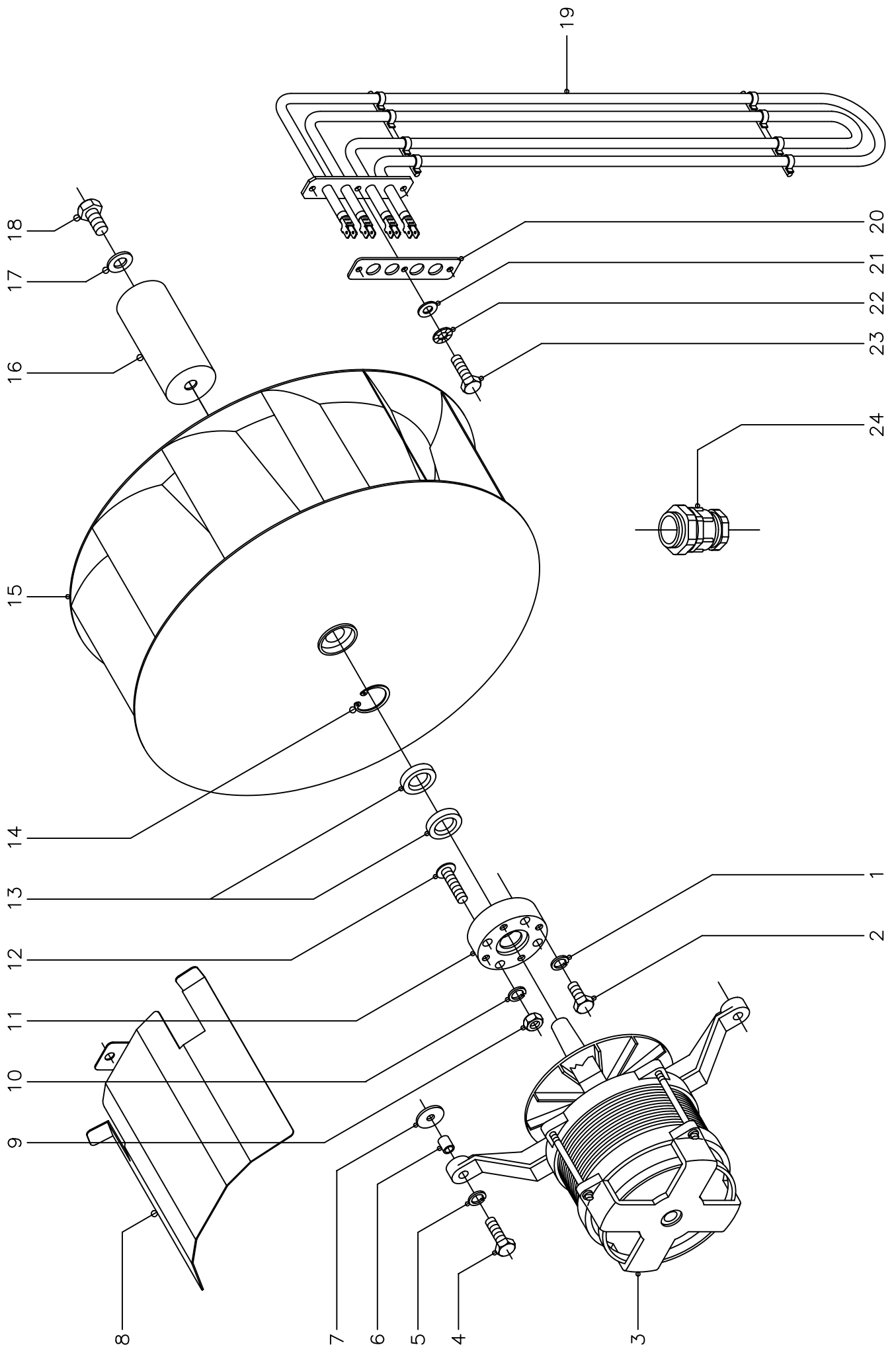

N plano C-1473	Firma 	Fecha 11-2003	Aparato HORNO HMM, HME, HMP-20/21	TURBINA	Lamina 5	Fagor Industrial S.Coop. FAGOR Onate
-------------------	-----------	------------------	--------------------------------------	---------	-------------	--

MOD.	HORNOS : HMM, HME, HMP-20/21	ZONA	TURBINA	PLANO	C-1473
------	------------------------------	------	---------	-------	--------

ITEM	CODIGO	DENOMINACION	TEXTO	HMM-20/21	HMM-2-20/11	HME-20/21	HME-2-20/11	HMP-20/21	HMP-2-20/11	HMM-20/21UL							NOTAS
1	Q232030	Arandela muelle A-5		8		8		8		8							
2	Q012031	Tornillo exagonal M-5x10		8		8		8		8							
3	R253049	Motor (220/240,380/415 V.,50/60 Hz.)		2		-		-		2							Trifasico
3	R663033	Motor (380/400 V., 50/60 Hz.)		-		2		2		-							Trifasico
3	R663034	Motor (220/230 V., 50/60 Hz.)		-		2		2		-							Trifasico
4	Q012044	Tornillo exagonal M-6x25		8		8		8		8							
5	Q262040	Arandela muelle A-6		8		8		8		8							
6	R663057	Casquillo amarre motor		-		8		8		-							
7	Q301304	Arandela calzo Ø 23xØ 6,5x2		8		8		8		8							
8	R142628	Tejadillo motor		2		2		2		2							
	Q012042	Tornillo exagonal M-6x15		2		2		2		2							
9	Q162040	Tuerca exagonal M-6		8		8		8		8							
10	Q262040	Arandela muelle A-6		8		8		8		8							
11	R662623	Casquillo reten		2		2		2		2							
12	-	Perno M-6 (Caldeado a cuerpo)		8		8		8		8							
13	R662627	Reten Ø 28xØ 17x7		4		4		4		4							
14	Q302023	Anillo de seguridad Ø 28x1,2		2		2		2		2							
15	R253042	Turbina		2		2		2		2							
16	R665025	Distribuidor inyeccion		-		1		1		-							
17	R763010	Arandela seguridad Hanning		2		2		2		2							
18	Q012063	Tornillo exagonal M-10x20		2		2		2		2							
19	R683000	Resistencia 2000+2000W., 230V.		12		12		12		12							
20	R673063	Junta resistencia		12		12		12		12							
21	Q232030	Arandela plana A-5		36		36		36		36							
22	Q242030	Arandela abanico A-5		36		36		36		36							
23	Q012031	Tornillo exagonal M-5x10		36		36		36		36							
24	R143010	Prensaestopas		1		1		1		1							

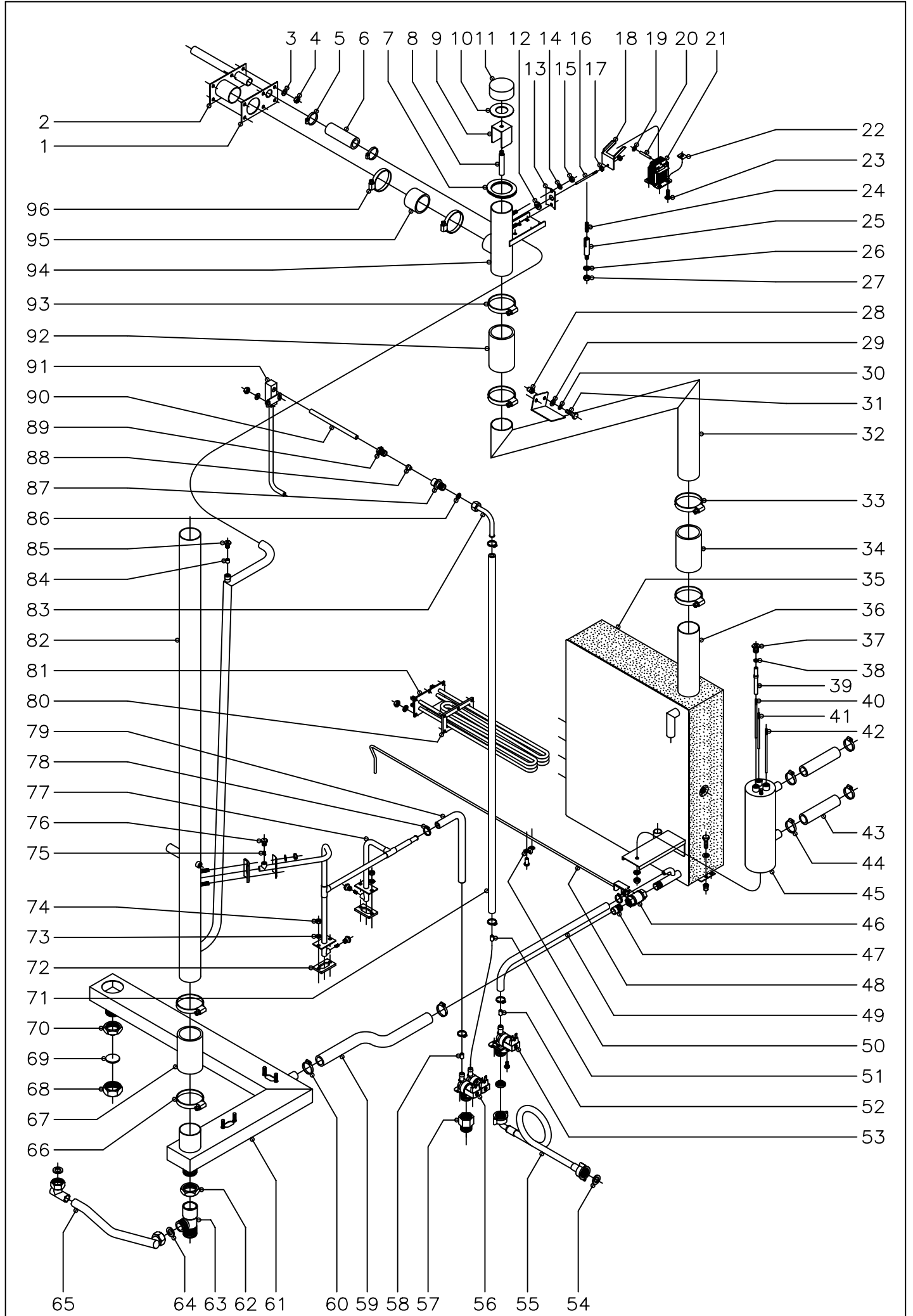

N plano C-1474	Firma <i>[Signature]</i>	Fecha 11-2003	Aparato CIRCUITO DE AGUA HORNOS HMM, HME, HMP-20/21	Lamina 6	Fagor Industrial S.Coop. FAGOR Onate
-------------------	-----------------------------	------------------	---	-------------	--

MOD.	HORNOS : HMM, HME, HMP-20/21	ZONA	CIRCUITO DE AGUA						PLANO	C-1474
------	------------------------------	------	------------------	--	--	--	--	--	-------	--------

ITEM	CODIGO	DENOMINACION	TEXTO	HMM-20/21	HMM-2-20/11	HME-20/21	HME-2-20/11	HMP-20/21	HMP-2-20/11	HMM-20/21UL							NOTAS
1	R675038	Junta entrada y retorno		1		1		1		1							
2	R022613	Tubo entrada y retorno vapor		1		1		1		1							
3	Q232040	Arandela plana A-6		6		6		6		6							
4	Q162040	Tuerca exagonal M-6		6		6		6		6							
5	Q881304	Abrazadera 20 - 32		2		2		2		2							
6	3715600	Tubo silicona forra. Ø26xØ18x100		1		1		1		1							
7	R662813	Pasamuros chimenea		1		1		1		1							
8	R675008	Union retencion de vapores		1		1		1		1							
9	R675005	Guia retencion de vapores		1		1		1		1							
10	R675007	Junta retencion de vapores		1		1		1		1							
11	R675006	Retencion de vapores		1		1		1		1							
12	R675033	Junta palanca accionamiento		1		1		1		1							
13	T115105	Amarre junta a conduccion vahos		1		1		1		1							
14	Q242030	Arandela abanico A-5		2		2		2		2							
15	Q162030	Tuerca exagonal M-5		2		2		2		2							
16	R675014	Palanca accionamiento		1		1		1		1							
17	Q162020	Tuerca exagonal M-4		2		2		2		2							
18	R672640	Escuadra accionamiento		1		1		1		1							
19	Q301035	Sujecion rapida Ø4		2		2		2		2							
20	R675016	Pasador electroiman		1		1		1		1							
21	R663030	Electroiman		1		1		1		1							
22	Q221012	Tuerca rapida M-5		2		2		2		2							
23	Q152004	Tornillo aplastado M-5x13		2		2		2		2							
24	Z883001	Resorte		1		1		1		1							
25	R665027	Guia resorte		1		1		1		1							
26	Q242040	Arandela abanico A-6		1		1		1		1							
27	Q162040	Tuerca exagonal M-6		1		1		1		1							
28	Q221343	Remache exagonal M-6		2		2		2		2							
29	Q232040	Arandela plana A-6		2		2		2		2							

MOD.		HORNOS : HMM, HME, HMP-20/21		ZONA	CIRCUITO DE AGUA								PLANO	C-1474		
ITEM	CODIGO	DENOMINACION	TEXTO	HMM-20/21	HMM-2-20/11	HME-20/21	HME-2-20/11	HMP-20/21	HMP-2-20/11	HMM-20/21UL						NOTAS
30	Q262040	Arandela muelle A-6		2		2		2		2						
31	Q012042	Tornillo exagonal M-6x15		2		2		2		2						
32	R145007	Conduccion de vapor		1		1		1		1						
33	Q881324	Abrazadera 50 - 70		2		2		2		2						
34	R345020	Tubo empalme Ø63xØ53x100		1		1		1		1						
35	R145015	Aislante de generador		1		1		1		1						
36	R145001	Generador de vapor		1		1		1		1						
37	R345058	Racord amarre electrodos		3		3		3		3						
38	Q163020	Tuerca exagonal M-4		6		6		6		6						
39	R345059	Guia aislante de electrodos		3		3		3		3						
40	R345063	Electrodo nivel bajo L=116		1		1		1		1						
41	R345060	Electrodo nivel alto L=106		1		1		1		1						
42	R345064	Electrodo de masa L=131		1		1		1		1						
43	3715600	Tubo silicona forra. Ø26xØ18x350		2		2		2		2						
44	Q881304	Abrazadera 20 - 32		4		4		4		4						
45	R025011	Cuerpo de niveles		1		1		1		1						
46	R015034	Cuerpo grifo vaciado		1		1		1		1						
47	R345014	Manguito grifo vaciado		1		1		1		1						
48	R032804	Palanca de grifo de vaciado		1		1		1		1						
49	3676900	Tubo de goma Ø17xØ10x300		1		1		1		1						
50	Q901306	Grapa amarre palanca grifo		1		1		1		1						
	Q412002	Remache tubular Ø4x7,5		2		2		2		2						
51	R665041	Regulador caudal (0,25 l./m.) verde		-		1		1		-						
52	Z601156	Regulador caudal (8 l./m.) rojo		1		1		1		1						
53	Z701135	Electrovalvula simple		1		1		1		1						
	Q032021	Tornillo alomado M-4x10		2		2		2		2						
54	Q307031	Arandela junta Ø24xØ14x3		2		2		2		-						
55	Z601114	Manguera entrada de agua		2		2		2		-						

MOD.	HORNOS : HMM, HME, HMP-20/21	ZONA	CIRCUITO DE AGUA	PLANO	C-1474
------	------------------------------	------	------------------	-------	--------

ITEM	CODIGO	DENOMINACION	TEXTO	HMM-20/21	HMM-2-20/11	HME-20/21	HME-2-20/11	HMP-20/21	HMP-2-20/11	HMM-20/21UL							NOTAS
56	P255001	Electrovalvula doble		-		1		1		-							
56	Z701135	Electrovalvula simple		1		-		-		1							
	Q032021	Tornillo alomado M-4x10		4		4		4		4							
57	T125033	Adaptador a rosca UL		-		-		-		1							
58	Z601156	Regulador caudal (8 l./m.) rojo		1		1		1		1							
59	3715600	Tubo silicona forra. Ø26xØ18x350		1		1		1		1							
60	Q881304	Abrazadera 20 - 32		2		2		2		2							
61	-	Tubo desague (soldado a cuerpo)		1		1		1		1							
62	Q223014	Contratuerca 1"		1		1		1		1							
63	R145036	Manguito desague		1		1		1		1							
64	Q307031	Arandela junta Ø24xØ14x3		2		2		2		2							
65	R145034	Conduccion recogeaguas		1		1		1		1							
66	Q881324	Abrazadera 50 - 70		2		2		2		2							
67	R345020	Tubo empalme Ø63xØ53x100		1		1		1		1							
68	R665053	Tuerca tapon 1"		1		1		1		1							
69	R015011	Arandela junta tapon Ø34x3		1		1		1		1							
70	Q223014	Contratuerca 1"		1		1		1		1							
71	3676900	Tubo de goma Ø17xØ10x1300		1		1		1		1							
72	R345108	Junta de vahos		3		3		3		3							
73	Q242030	Arandela abanico A-5		6		6		6		6							
74	Q162030	Tuerca exagonal M-5		6		6		6		6							
75	Z651932	Rodete		3		3		3		3							
76	Z651931	Tobera		3		3		3		3							
77	R145024	Conduccion condensacion		1		1		1		1							
78	Q881302	Abrazadera 12 - 20		6		6		6		6							
79	3676900	Tubo de goma Ø17xØ10x300		1		1		1		1							
80	R145012	Junta cierre resistencias		4		4		4		4							
81	R143000	Resistencia (3000W.x3, 230 V.)		4		4		4		4							
	Q232030	Arandela plana A-5		12		12		12		12							

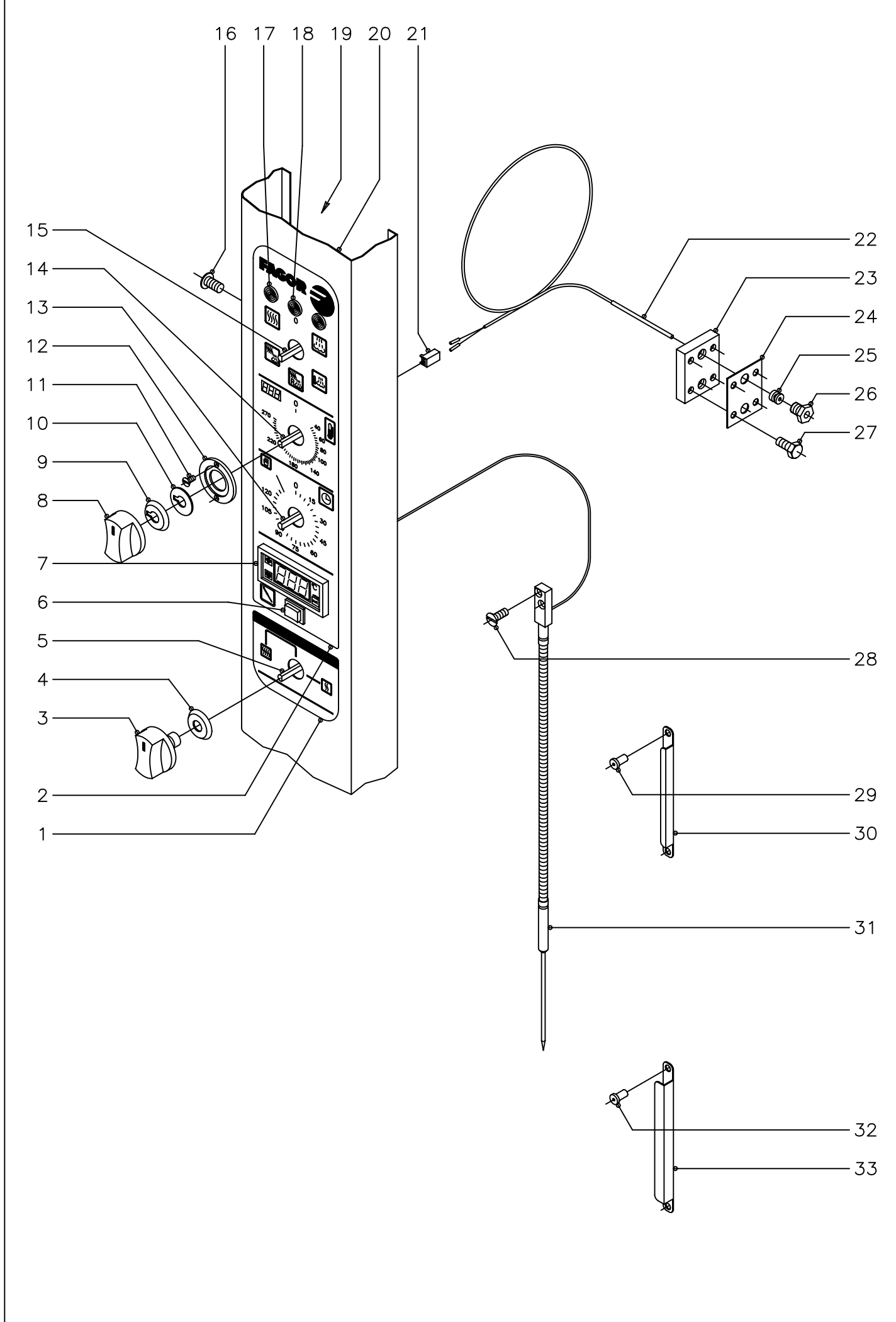

MOD.	HORNOS : HMM-20/21	ZONA	SISTEMA ELECTRICO PORTAMANDOS	PLANO	C-1475
------	---------------------------	------	--------------------------------------	-------	---------------

ITEM	CODIGO	DENOMINACION	TEXTO	HMM-20/21	HMM-2-20/11	HMM-20/21UL									NOTAS
1	R693000	Serigrafia inferior (conmutador)		1	1										
2	R743012	Serigrafia superior (controlador)		1	-										
2	R743070	Serigrafia superior (controlador)		-	1										
3	R663062	Boton de mando (conmutadores)		3	3										
4	R663046	Junta (conmutadores)		3	3										
5	R753000	Conmutador de potencia		1	1										
6	R743008	Interruptor regulacion sonda		1	1										
7	R743091	Termostato digital ° C.		1	-										
7	R743035	Termostato digital ° F.		-	1										
8	R663063	Boton de mando (circuito impreso)		1	1										
9	R663045	Junta (circuito impreso)		1	1										
10	R662810	Arandela guia		1	1										
11	Q151346	Tornillo avellanado M-3x5		2	2										
12	R662809	Guia boton de mando		1	1										
13	R723000	Temporizador manual		1	1										
14	R743013	Termostato electronico 270°C.		1	-										
14	R693058	Termostato electronico 500°F.		-	1										
15	R743002	Conmutador de funciones		1	1										
16	Q152004	Tornillo aplastado M-5x13		3	3										
17	R693056	Piloto ambar		2	2										
18	R693055	Piloto verde		1	1										
19	R742803	Soporte componentes		1	1										
20	R772805	Panel portamandos		1	1										
21	R663092	Conector 2 vias		1	1										
22	R663090	Conjunto termopar L=1500		1	1										
23	R662659	Pasamuros doble para sonda		1	1										
24	R692811	Junta pasamuros doble		1	1										
25	R662652	Bicono cierre sonda		1	1										
26	R662629	Racord cierre sonda		1	1										

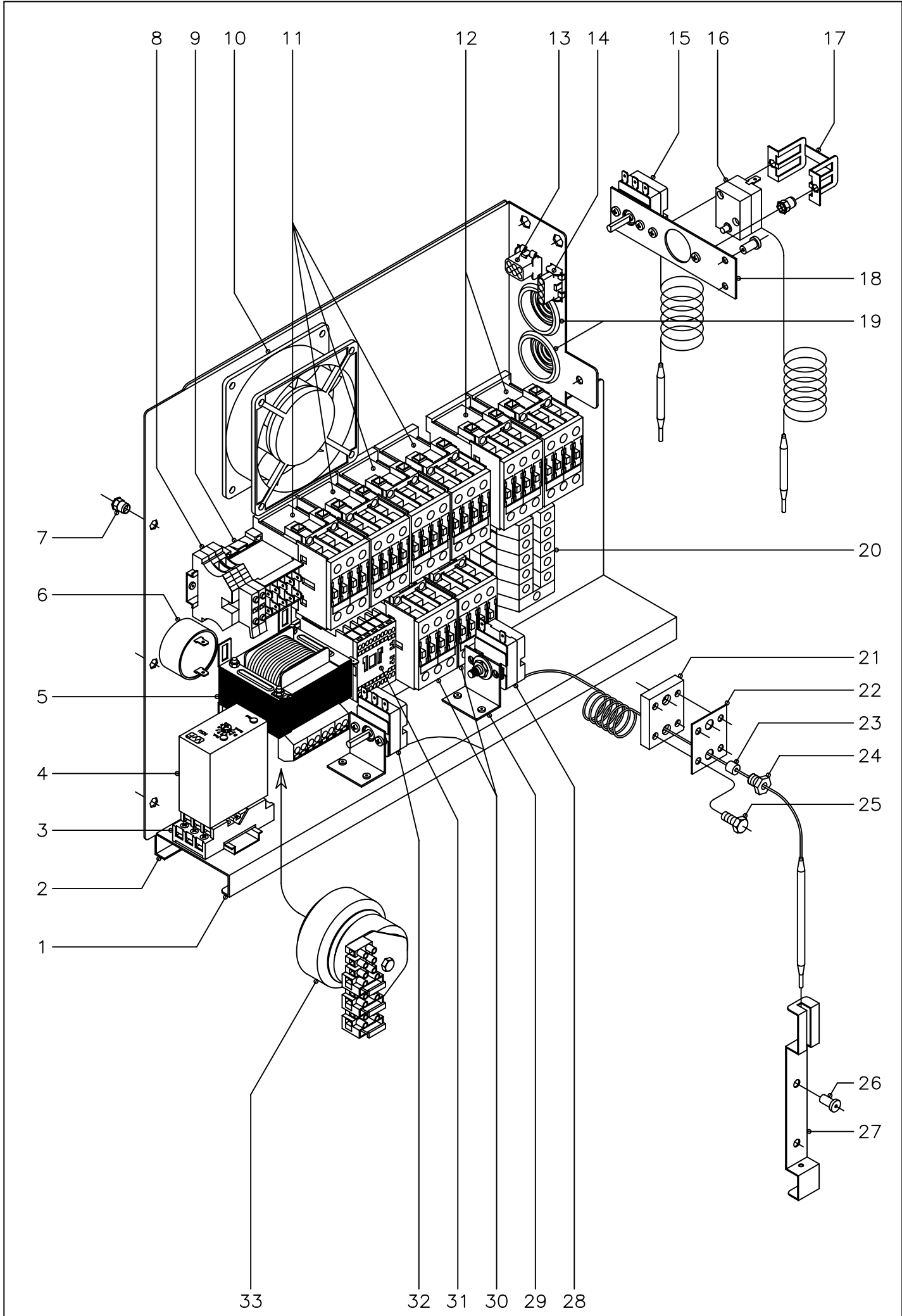

N plano C-1476	Firma 	Fecha 11-2003	Aparato CUADRO ELECTRICO HORNOS HMM-20/21	Lamina 8	Fagor Industrial S.Coop. FAGOR Oñate
-------------------	--	------------------	---	-------------	--



MOD.	HORNOS : HMM-20/21	ZONA	CUADRO ELECTRICO	PLANO	C-1476
------	--------------------	------	------------------	-------	--------

ITEM	CODIGO	DENOMINACION	TEXTO	HMM-20/21	HMM-2-20/11	HMM-20/21UL								NOTAS
1	R143001	Panel cuadro electrico		1	1									
2	R663018	Contra guia panel cuadro		1	1									
	Q412002	Remache tubular Ø4x7,5		7	7									
3	R743009	Base enchufable		1	1									
	Z123018	Guia contactor L=55		1	1									
4	R343072	Detector de niveles		1	-									
4	R743031	Detector de niveles		-	1									
5	R503005	Transformador		1	1									
6	R693067	Zumbador		1	1									
7	Q221342	Remache exagonal M-5		3	3									
8	R073005	Bornas portafusibles		2	2									
	P184011	Cartucho fusible 4 A.		2	2									
	Z263303	Tope final		1	1									
9	Z683087	Contactador 3TF20 01 - 3AL2 (230 V.)		1	1									
	Z263303	Tope final		1	1									
10	Z103066	Ventilador		1	1									
11	X183011	Contactador 3RT-1024-1AN20 230V.		4	4									
	R693009	Guia contactor L=250		1	1									
12	X183011	Contactador 3RT-1024-1AN20 230V.		2	2									
	Z403016	Guia contactor L=100		1	1									
13	-	Conector hembra 6 vias		1	1									
14	-	Conector hembra 4 vias		1	1									
15	R343100	Termostato de condensacion		1	1									
	Q153111	Tornillo alomado M-4x8		2	2									
16	Z213014	Termostato Tecasa de seguridad		1	1									
17	Z203060	Amarre limitador Tecasa		1	1									
	Q221341	Remache exagonal M-4		2	2									
	Q153111	Tornillo alomado M-4x8		2	2									
18	R673061	Soporte amarre termostatos		1	1									

MOD.	HORNOS : HMM-20/21	ZONA	CUADRO ELECTRICO	PLANO	C-1476
------	--------------------	------	------------------	-------	--------

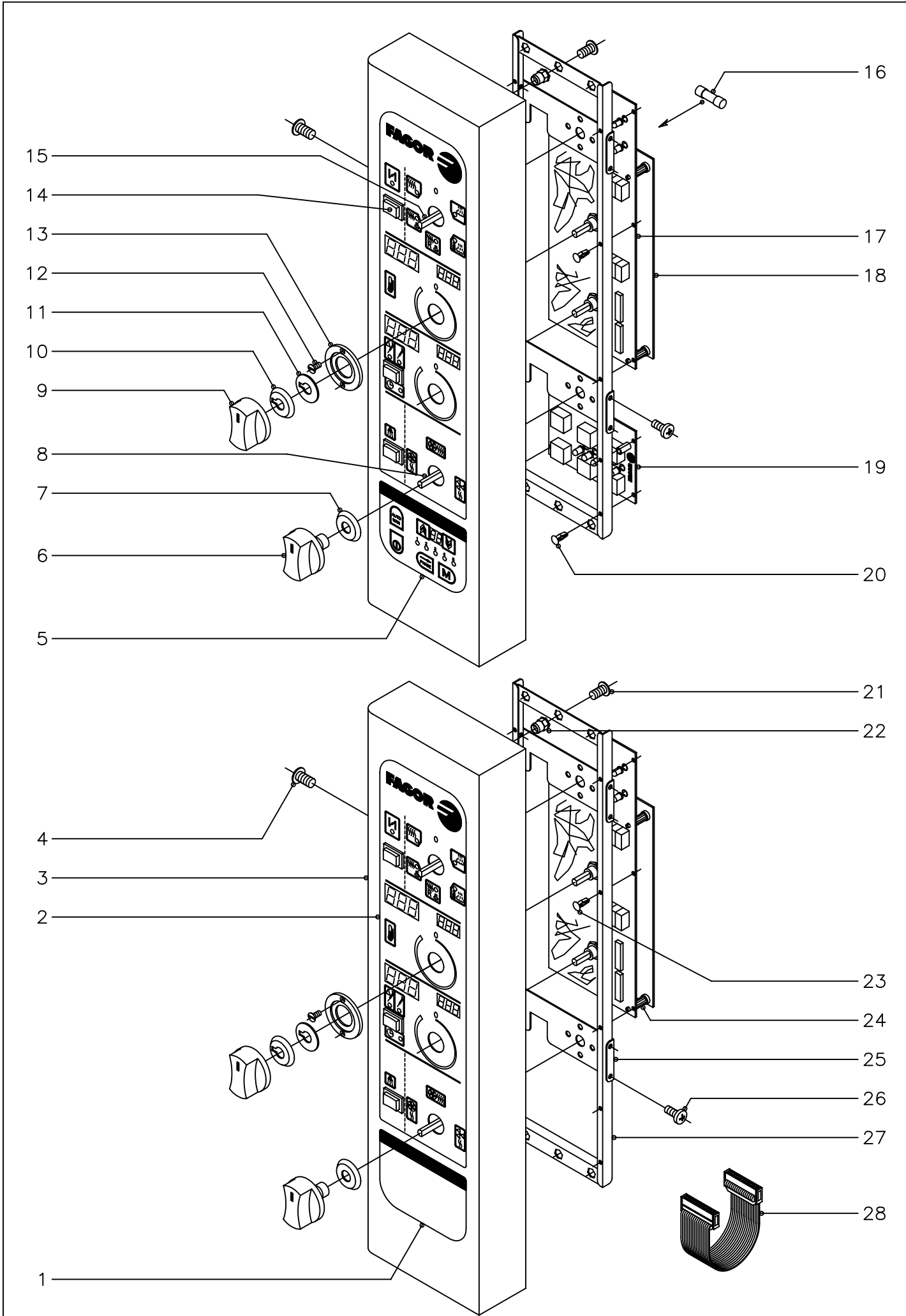
ITEM	CODIGO	DENOMINACION	TEXTO	HMM-20/21	HMM-2-20/11	HMM-20/21UL									NOTAS
	Q412002	Remache tubular Ø4x7,5		2	2										
19	N103013	Pasacables		2	2										
20	R143011	Borne gris fases 70		3	3										
	R143012	Borne azul neutro 70		1	1										
	Z103035	Borne verde-amarillo tierra 35		1	1										
	Z683096	Tope final 35		1	1										
	Z683068	Señalización bornes		1	1										
	R663055	Guía contactor 120		1	1										
21	R662659	Pasamuros doble para sonda		1	1										
22	R692811	Junta pasamuros doble		1	1										
23	R662662	Junta cierre bulbo limitador		1	1										
24	R662629	Racord cierre sonda		1	1										
25	Q012021	Tornillo exagonal M-4x10		4	4										
26	Q412002	Remache tubular Ø4x7,5		2	2										
27	R662630	Soporte de bulbo		1	1										
28	R243016	Termostato limitador temperatura		1	1										
29	R343039	Soporte de termostatos		2	2										
30	X183011	Contactador 3RT-1024-1AN20 230V.		2	2										
31	Z203050	Contactador sirius 3RT-1016-2AP01		1	1										
	Z123019	Guía contactor 175		1	1										
32	R343018	Termostato a tubo retorno vapor		1	1										
33	R723063	Transformador UL		-	1										



N plano C-1477	Firma 	Fecha 11-2003	Aparato SISTEMA ELECTRICO PORTAMANDOS HORNOS HME, HMP-20/21	Lamina 9	Fagor Industrial S.Coop. FAGOR  Onate
-------------------	--	------------------	---	-------------	--

MOD.	HORNOS : HME, HMP-20/21	ZONA	SISTEMA ELECTRICO PORTAMANDOS	PLANO	C-1477
------	-------------------------	------	-------------------------------	-------	--------

ITEM	CODIGO	DENOMINACION	TEXTO	HME-20/21	HME-2-20/11	HMP-20/21	HMP-2-20/11									NOTAS
1	R663014	Serigrafia inferior (neutra)		1		-										
2	R673000	Serigrafia superior (controlador)		1		1										
3	R092837	Panel portamandos		1		1										
4	Q152004	Tornillo aplastado M-5x13		3		3										
5	R663010	Serigrafia inferior (programador)		-		1										
6	R663062	Boton de mando (conmutadores)		2		2										
7	R663046	Junta (conmutadores)		2		2										
8	R663026	Conmutador de funciones		1		1										
9	R663063	Boton de mando (electronica)		2		2										
10	R663045	Junta (circuito impreso)		2		2										
11	R662810	Arandela guia		2		2										
12	Q151346	Tornillo avellanado M-3x5		4		4										
13	R662809	Guia boton de mando		2		2										
14	R663032	Pulsador		3		3										
15	R663025	Conmutador de funciones		1		1										
16	R663101	Fusible 1 A.		1		1										
17	R663050	Circuito impreso mando		1		1										
18	R663085	Circuito impreso control		1		1										
19	R663004	Circuito impreso programador		-		1										
20	R663036	Remache fijacion circuito		-		4										
21	Q152004	Tornillo aplastado M-5x13		2		2										
22	Q221342	Remache exagonal M-5		2		2										
23	R663036	Remache fijacion circuito		6		6										
24	R663035	Separador		4		4										
25	R663008	Soporte conmutadores		2		2										
26	Q151320	Tornillo alomado M-4x6		8		8										
27	R663005	Soporte circuitos impresos		1		1										
28	R663102	Conector de circuitos		1		1										

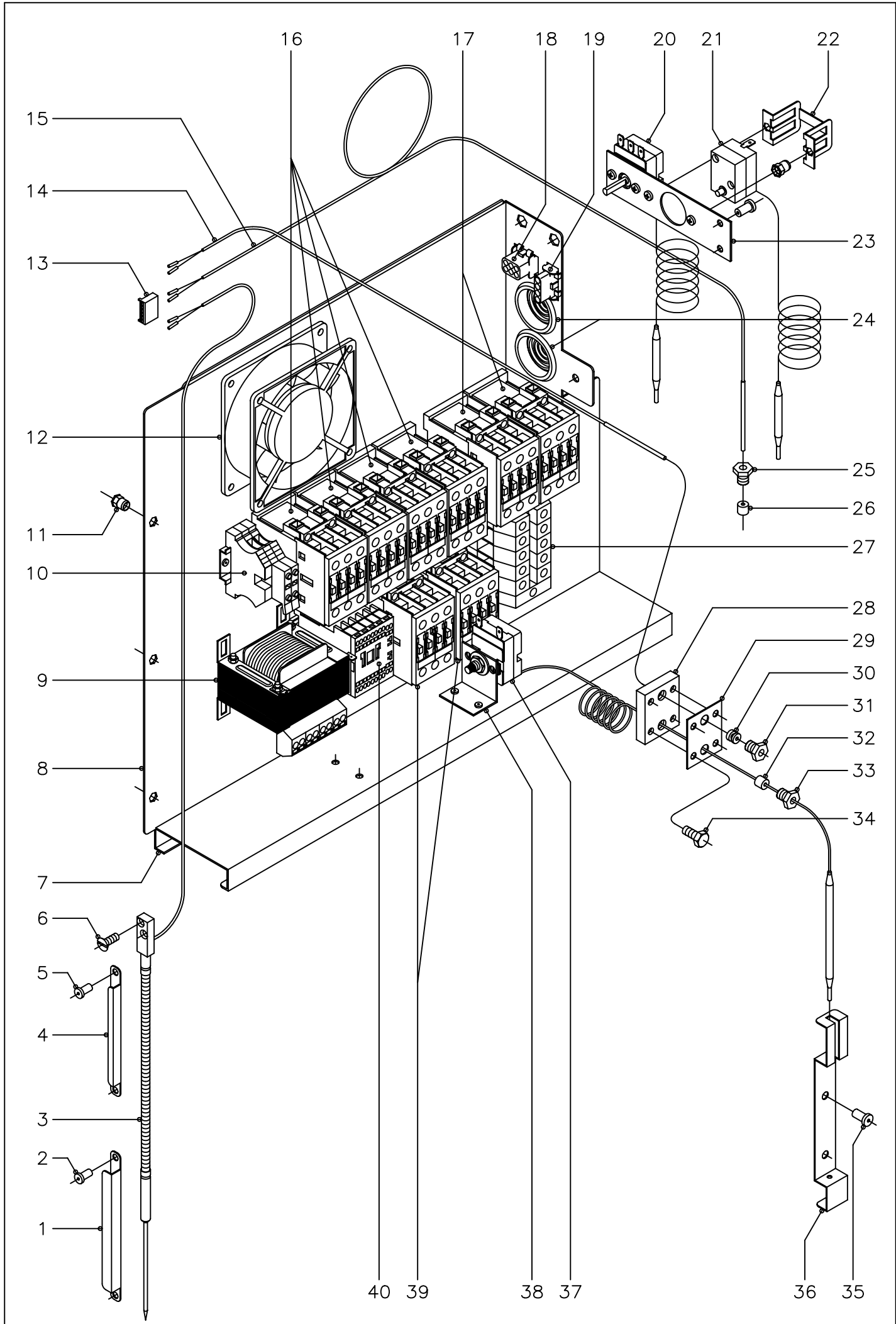

N plano C-1478	Firma 	Fecha 11-2003	Aparato CUADRO ELECTRICO HORNOS HME, HMP-20/21	Lamina 10	Fagor Industrial S.Coop. FAGOR Onate
-------------------	--	------------------	--	--------------	--

MOD.	HORNOS : HME, HMP-20/21	ZONA	CUADRO ELECTRICO	PLANO	C-1478
------	-------------------------	------	------------------	-------	--------

ITEM	CODIGO	DENOMINACION	TEXTO	HME-20/21	HME-2-20/11	HMP-20/21	HMP-2-20/11								NOTAS
1	R672643	Soporte de sonda		1		1									
2	Q412002	Remache tubular Ø4x7,5		2		2									
3	R093019	Conjunto sonda nucleo		1		1									
4	R092633	Retenedor de sonda		2		2									
5	Q412002	Remache tubular Ø4x7,5		2		2									
6	Q042022	Tornillo avellanado M-4x15		2		2									
7	R663018	Contra guia panel cuadro		1		1									
	Q412002	Remache tubular Ø4x7,5		7		7									
8	R143001	Panel cuadro electrico		1		1									
9	R503005	Transformador		1		1									
10	R073005	Bornas portafusibles		2		2									
	P184011	Cartucho fusible 4 A.		2		2									
	Z263303	Tope final		1		1									
11	Q221342	Remache exagonal M-5		3		3									
12	Z103066	Ventilador		1		1									
13	R663093	Conector 6 vias		1		1									
14	R663090	Conjunto termopar L=1500		1		1									
15	R663089	Conjunto termopar L=2500		1		1									
16	X183011	Contactador 3RT-1024-1AN20 230V.		4		4									
	R693009	Guia contactor L=250		1		1									
17	X183011	Contactador 3RT-1024-1AN20 230V.		2		2									
	Z403016	Guia contactor L=100		1		1									
18	-	Conector hembra 6vias		1		1									
19	-	Conector hembra 4vias		1		1									
20	R343100	Termostato de condensacion		1		1									
	Q153111	Tornillo alomado M-4x8		2		2									
21	Z213014	Termostato Tecasa de seguridad		1		1									
22	Z203060	Amarre limitador Tecasa		1		1									
	Q221341	Remache exagonal M-4		2		2									

MOD.	HORNOS : HME, HMP-20/21	ZONA	CUADRO ELECTRICO	PLANO	C-1478
------	-------------------------	------	------------------	-------	--------

ITEM	CODIGO	DENOMINACION	TEXTO	HME-20/21	HME-2-20/11	HMP-20/21	HMP-2-20/11									NOTAS
	Q153111	Tornillo alomado M-4x8		2		2										
23	R673061	Soporte amarre termostatos		1		1										
	Q412002	Remache tubular Ø4x7,5		2		2										
24	N103013	Pasacables		2		2										
25	R662629	Racord cierre sonda		1		1										
26	3712400	Tube-junta de silicona Ø8xØ3x20		1		1										
27	R143011	Borne gris fases 70		3		3										
	R143012	Borne azul neutro 70		1		1										
	Z103035	Borne verde-amarillo tierra 35		1		1										
	Z683096	Tope final 35		1		1										
	Z683068	Señalización bornes		1		1										
	R663055	Guia contactor 120		1		1										
28	R662659	Pasamuros doble para sonda		1		1										
29	R692811	Junta pasamuros doble		1		1										
30	R662652	Bicono cierre sonda		1		1										
31	R662629	Racord cierre sonda		1		1										
32	R662662	Junta cierre bulbo limitador		1		1										
33	R662629	Racord cierre sonda		1		1										
34	Q012021	Tornillo exagonal M-4x10		4		4										
35	Q412002	Remache tubular Ø4x7,5		2		2										
36	R662630	Soporte de bulbo		1		1										
37	R243016	Termostato limitador temperatura		1		1										
38	R343039	Soporte de termostatos		1		1										
39	X183011	Contactador 3RT-1024-1AN20 230V.		2		2										
40	Z203050	Contactador sirius 3RT-1016-2AP01		1		1										
	Z123019	Guia contactor 175		1		1										

MOD.		HORNOS : HMM, HME, HMP-20/21		ZONA		VARIOS				PLANO			
ITEM	CODIGO	DENOMINACION	TEXTO	HMM-20/21	HMM-2-20/11	HME-20/21	HME-2-20/11	HMP-20/21	HMP-2-20/11	HMM-20/21UL			NOTAS
	R746501	Folleto de instrucciones		1	-	-	-	-	-				
	R666501	Folleto de instrucciones		-	1	1	-	-	-				
	R696516	Folleto de instrucciones		-	-	-	-	1					
	R503003	Esquema electrico adhesivo		1	-	-	-	-	-				Plano HC-72273
	R143019	Esquema electrico adhesivo		-	1	1	-	-	-				Plano HC-74199
	R753025	Esquema electrico adhesivo		-	-	-	-	1					Plano HC-74750
	R503004	Esquema electrico de montaje		1	-	-	-	1					Plano HD-12493
	R143018	Esquema electrico de montaje		-	1	1	-	-					Plano HD-12681
	R503009	Instalacion electrica HMM		1	-	-	-	-					
	R143017	Instalacion electrica HME, HMP		-	1	1	-	-					
	R503008	Instalacion electrica HMM, (UL)		-	-	-	-	1					
	R143005	Cableado fuerza conveccion		2	2	2	-	-					
	R143015	Cableado fuerza conveccion		-	-	-	-	2					
	R503000	Instalacion fuerza cuadro electrico		1	1	1	-	-					
	R503006	Instalacion fuerza cuadro electrico		-	-	-	-	1					
	R663095	Cableado luz interior		1	1	1	1	1					
	R093021	Cableado luz puerta		1	1	1	-	-					
	R093011	Cableado luz puerta		-	-	-	-	1					
	R093004	Cable auxiliar prolongador		2	2	2	-	-					
	R093012	Cable auxiliar prolongador		-	-	-	-	2					
	3713900	Funda roja-negra Ø6,4x500		1	1	1	1	1					
	R143004	Cableado fuerza vapor		2	2	2	-	-					
	R143014	Cableado fuerza vapor		-	-	-	-	2					
	R143009	Instalacion doble potencia		1	1	1	-	-					
	R143016	Instalacion doble potencia		-	-	-	-	1					

3N~50/60Hz 380/415V

MODELO HMM-20/11 HMM-20/21

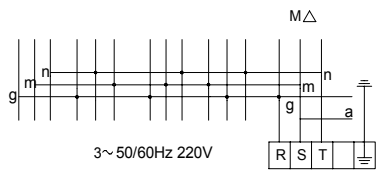
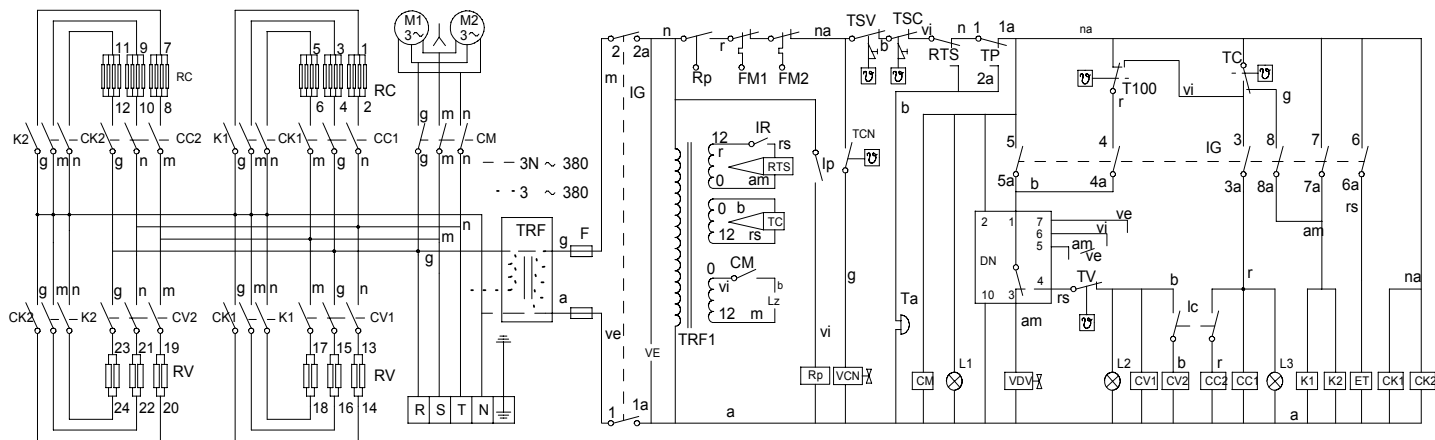

am/ve = amarillo/verde-yellow/green-jaune/vert
 am = amarillo-yellow-jaune
 a = azul-blue-bleu
 b = blanco-white-blanc
 g = gris-grey-gris
 ve = verde-green-vert

na = naranja-orange-orange
 r = rojo-red-rouge
 m = marron-brown-marron
 n = negro-black-noir
 rs = rosa-pink-rose
 vi = violeta-violet-violette

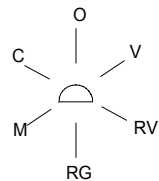

Mode	1 1a	2 2a	3 3a	4 4a-5a	5-6-7 6a-7a-8a	8
OFF						
VAPOR	X	X		X	X	
Reg. Vapor	X	X		X	X	
REGENERAC.	X	X	X	X		X
MIXTO	X	X	X	X		
CONVECCION	X	X	X		X	X

R-503003 HC-72273

- IP = Interruptor puerta
- IG = Interruptor general
- F = Fusible
- CM = Contactor motor
- VDV = Electroválvula calderín
- DN = Detector de nivel
- FM1, FM2 = Térmico motor
- TSV = Termostato seguridad vapor
- TSC = Termostato seguridad cámara
- LZ = Luz interior
- IR = Selector regulador sonda nucleo
- RTS = Regulador temperatura sonda nucleo
- RV = Resistencias vapor
- VE = Ventilador cuadro eléctrico
- Ta = Timbre avisador
- RP = Relé puerta
- ET = Electroimán de apertura de tiro
- Ic = Selector de potencia
- VCN = Electroválvula de condensación de vapor
- TC = Termostato cámara
- T100 = Termostato fijo 100°C
- TV = Termostato vapor
- M1, M2 = Motor
- CC1, CC2 = Contactor resistencia cámara
- CV1, CV2 = Contactor resistencia vapor
- CK1, CK2, K1, K2 = Relé resistencias
- TCN = Termostato de condensación vapor
- RC = Resistencias cámara
- TRF, TRF1 = Transformador
- L1 = Lámpara de funcionamiento
- L2 = Lámpara de calentamiento vapor
- L3 = Lámpara de calentamiento cámara

ESQUEMA TEORICO ADHESIVO		R-503003			
Nº	Pieza	Cant.	Material	Nº Clasificación	Acabado
Nº	Modificación		Propuesta de	Fecha	Tolerancias generales
1	Modificar TSV, TSC y TCN		Maillo	2/10/96	<5± 5-25± : > 100± 25-50± : <X±
2	Modif. general (pasar a fabric. interior)		Plazaola	29/4/97	
3	Eliminar filtro interferencias		Maillo	25/4/98	
4	Introducir Rp		Maillo	25/2/02	
Dibujado		Firma	Fecha	Mecanizado superficial	
Proyectado		KONTXI	11/3/98	FAGOR	
Comprobado				Fagor Industrial, Koop, Elk, Mugatua	
Escala		Horno Mixto HMM			Plano numero
					HC-72273 -4
		Plano hau ez dateke erabili ez berritza gure baimenitz gabe			Sustituido por
					Sustituido por

3N~50/60Hz 380/415V

MODELO HME-20/11 HMP-20/11

HME-20/21 HMP-20/21

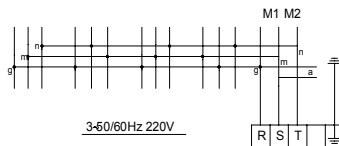
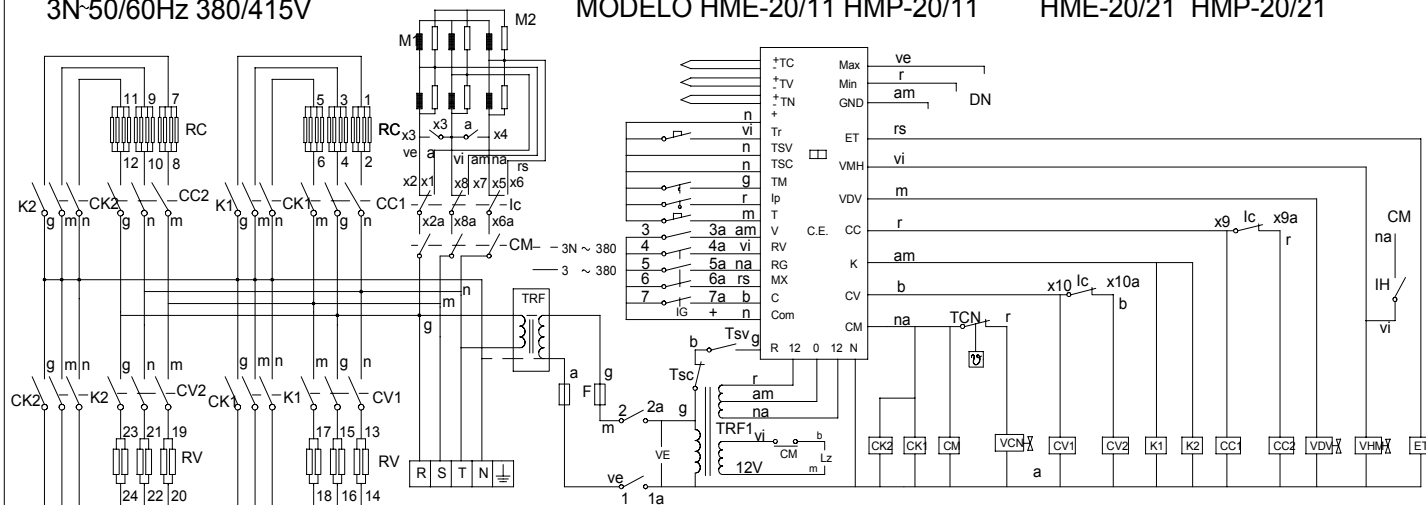

- IP = Door's switch
- IG = General switch
- F = Fuse
- CM = Motor's relay
- VDV = Steamer's solenoid
- DN = Water level control
- TM = Motor's thermal protection
- TSV = Steamer's security thermostat
- TSC = Convection's security thermostat
- LZ = Indoor light
- VHM = Humidify water solenoid
- CE = Electronic main control
- RV = Steamer elements
- VE = Control panel's fan
- Tr = Chimney selector
- TRF, TRF1 = Transformer
- ET = Chimney solenoid
- Ic = Power reduction switch
- VCN = Steamer condenser solenoid
- TC = Convection probe
- TN = Food probe
- M1, M2 = Motor
- CC1, CC2 = Heating air relays
- CV1, CV2 = Heating water relays
- CK1, CK2, K1, K2 = Elements relays
- TCN = Steam condenser thermostat
- IH = Humidity switch
- T = Timer or Food probe selector
- RC = Heating element

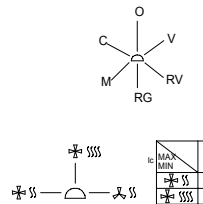

Mode	1	2	3	4	5	6	7
	1a	2a	3a	4a	5a	6a	7a
OFF							
VAPOR	X	X					
REG. VAPOR	X	X	X				
REGENERAC.	X	X			X		
MIXTO	X	X				X	
CONVECCION	X	X					X

IC	MIN	x1	x2 - x3	x4 - x5	x6	x7	x8	x9	x10
		x1a - x2a	x3a - x4a	x5a - x6a	x7a - x8a	x9a	x10a		
MIN	X	X	X	X	X	X	X	X	X
MAX	X	X	X	X	X	X	X	X	X
VE	X	X	X	X	X	X	X	X	X

- am/ve = amarillo-verde-yellow-green-jaune-vert
- am = amarillo-yellow-jaune
- a = azul-blue-bleu
- b = blanco-white-blanc
- g = gris-grey -gris
- ve = verde-green-vert
- na = naranja-orange-orange
- r = rojo-red-rouge
- m = marron-brown-marron
- n = negro-black-noir
- rs = rosa-pink-rose
- vi = violeta-violet-violette

R-143019

HC-74199

			3~50/60Hz 220V		
	ESQUEMA TEORICO ADHESIVO		3N~50/60Hz 380/415V	R-143019	
Nº	Pieza	Cant.	Material	Nº Clasificacion	Acabado
Nº	Modificacion		Propuesta de	Fecha	Tolerancias generales
					<5±
					5-25±
					25-50±
					50-100±
					> 100±
					∞±
Dibujado	Firma	Fecha			Mecanizado superficial
Proyectado	Iraxte	17/3/99			
Comprobado					Fagor Industrial, Koop, Elk, Mugatua
Escala	<p style="text-align: center;">HORNO MIXTO HME HMP</p>			Plano numero	HC-74199
	Plano hau ez dateke erabili ez berritza gure baimenitz gabe			Sustituye al Nº	hc-72270
				Sustituido por	

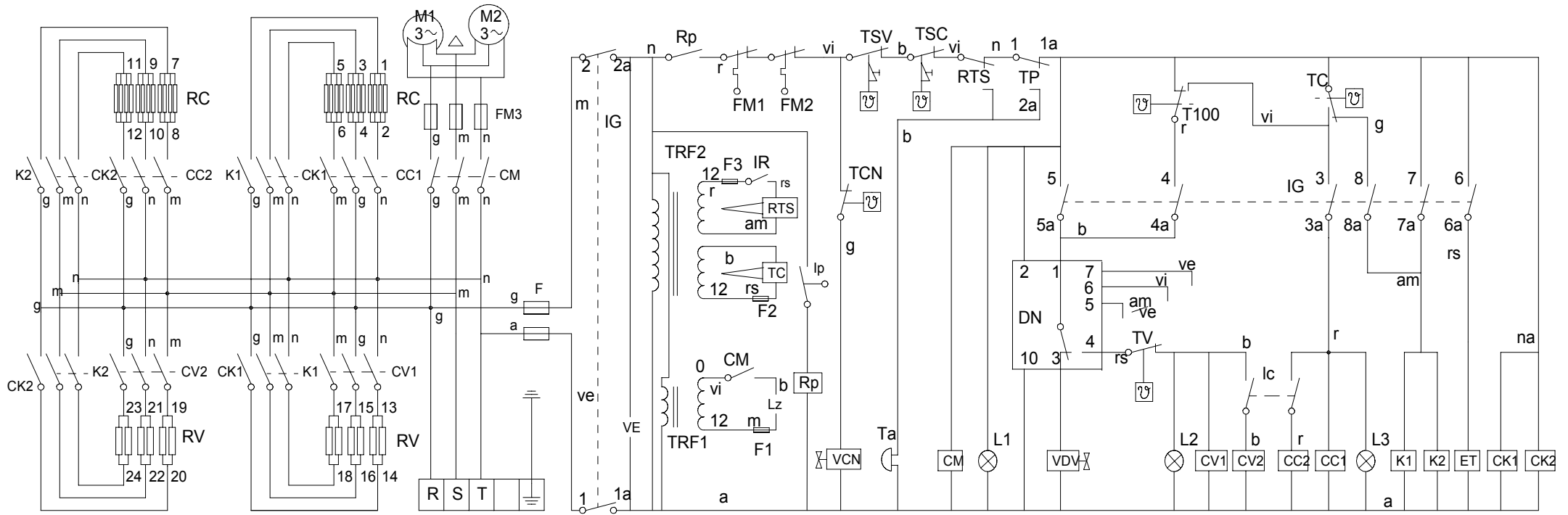

FM3 = Motor fuse

IP = Door's switch

IG = General switch

F = Fuse

CM = Motor's relay

VDV = Steamer's solenoid

DN = Water level control

FM1, FM2 = Motor's thermal protection

TSV = Steamer's security thermostat

TSC = Convection's security thermostat

LZ = Indoor light

IR = Probe selector

RTS = Probe controller

RV = Steamer elements

ET = Chimney solenoid

Ic = Power reduction switch

VCN = Steamer condenser solenoid

TC = Convection thermostat

T100 = 100 °C thermostat

TV = Steamer's thermostat

M1, M2 = Motor

CC1, CC2 = Heating air relays

CV1, CV2 = Heating water relays

CK1, CK2, K1, K2 = Elements relays

TCN = Steam condenser thermostat

RC = Heating element

TRF2= Transformer (Electronic thermostat)

VE = Control panel's fan

Ta = Alarm

Tp = Manual Timer

F1, F2, F3 = Transformer fuse

TRF1 = Transformer (Indoor light)

L1 = Pilot lamp (on/off)

L2 = Pilot lamp (Heating water)

L3 = Pilot lamp (Heating air)

Rp = Door's relay

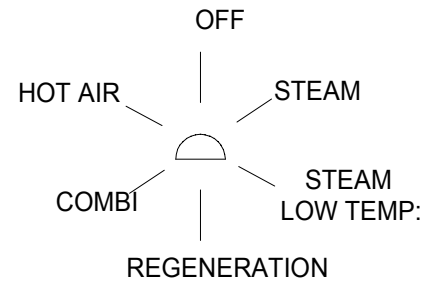

Mode \	1 1a	2 2a	3 3a	4 4a-5a	5-6 6a	7-8 7a-8a	8
OFF							
STEAM	X	X			X		X
STEAM LOW TEMP	X	X		X			X
REGENERATION	X	X	X	X			X
COMBI	X	X	X	X			
HOT AIR	X	X	X			X	X

am/ve = amarillo/verde-yellow/green-jaune/vert
 am = amarillo-yellow-jaune
 a = azul-blue-bleu
 b = blanco-white-blanc
 g = gris-grey -gris
 ve = verde-green-vert

na = naranja-orange-orange
 r = rojo-red-rouge
 m = marron-brown-marron
 n = negro-black-noir
 rs = rosa-pink-rose
 vi = violeta-violet-violette

