

**Hornos Mixtos Gas
Fours Mixtes á Gaz
Combined Gas Ovens
Gas-Konvektionsöfen
Forni Misti a Gas**

SERIE "EVOLUTION"

Modelos:

HGC-10/21

Febrero 2005 February

FAGOR 

Fagor Industrial

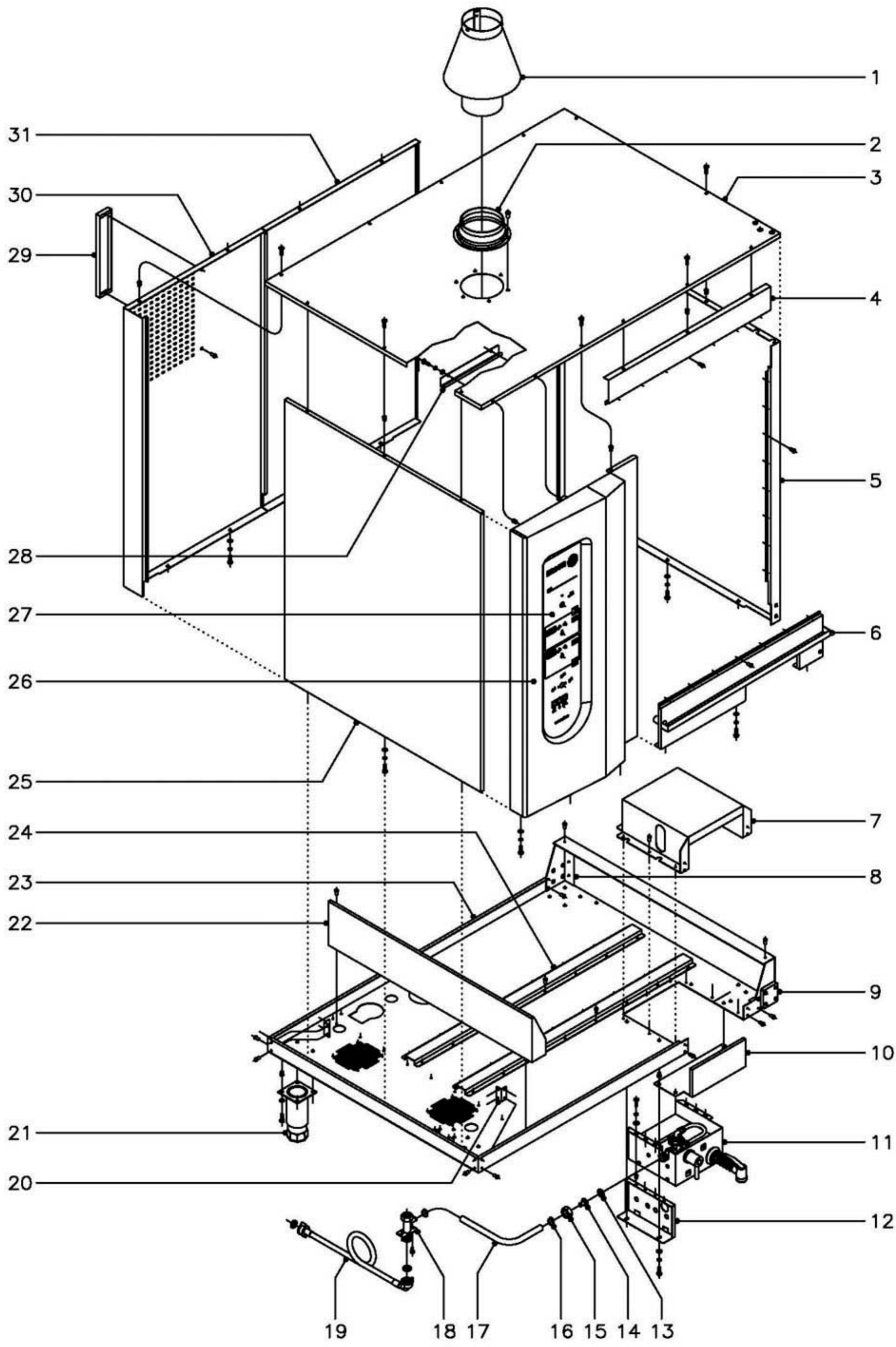

N plano C-1617	Firma 	Fecha 2-2005	Aparato MUEBLE HORNO A GAS HGC-10/21	Lamina 1	Fagor Industrial S.Coop. FAGOR Onate
-------------------	-----------	-----------------	--	-------------	--

ITEM	CODIGO	DENOMINACION	TEXTO	HGC-10 / 21									NOTAS
1	R272612	Chimenea	Chimney	1									
	R292646	Conducto humos	Smoke conduct	1									
	R272614	Soporte chimenea	Chimney holder	3									
	Q412002	Remache tubular Ø4x7,5	Tubular rivet Ø4x7.5	9									
2	R292645	Guia chimenea	Chimney guide	1									
	Q412002	Remache tubular Ø4x7,5	Tubular rivet Ø4x7.5	6									
3	T342800	Panel superior exterior	Outer upper panel	1									
	Q221342	Remache exagonal M-5	Hexagonal rivet M-5	13									
	Q152004	Tornillo aplastado M-5x13	Flat screw M-5x13	13									
4	T302804	Panel anterior superior	Upper front panel	1									
	Q412002	Remache tubular Ø4x7,5	Tubular rivet Ø4x7.5	7									Amarre a cuba
5	T302803	Panel exterior derecho	Right outer panel	1									
	Q012042	Tornillo exagonal M-6x15	Hexagonal screw M-6x15	3									Amarre inferior
	Q262040	Arandela grower A-6	Grower washer A-6	3									Amarre inferior
	Q232040	Arandela plana A-6	Flat washer A-6	3									Amarre inferior
	Q221343	Remache exagonal M-6	Hexagonal rivet M-6	3									Amarre inferior
	Q412002	Remache tubular Ø4x7,5	Tubular rivet Ø4x7.5	7									Amarre a cuba
6	T302800	Recogeaguas completo	Complete water collector	1									
	Q012042	Tornillo exagonal M-6x15	Hexagonal screw M-6x15	3									Amarre inferior
	Q262040	Arandela grower A-6	Grower washer A-6	3									Amarre inferior
	Q232040	Arandela plana A-6	Flat washer A-6	3									Amarre inferior
	Q221343	Remache exagonal M-6	Hexagonal rivet M-6	3									Amarre inferior
	Q412002	Remache tubular Ø4x7,5	Tubular rivet Ø4x7.5	7									Amarre a cuba
7	T302830	Alojamiento ducha	Shower housing	1									
	Q412002	Remache tubular Ø4x7,5	Tubular rivet Ø4x7.5	13									Amarre a base
8	T302816	Refuerzo apoyo base posterior	Rear base reinforcement	1									
	Q412002	Remache tubular Ø4x7,5	Tubular rivet Ø4x7.5	6									Amarre a base
9	T302836	Refuerzo apoyo base anterior com.	Com. front base holder rein	1									
	Q412002	Remache tubular Ø4x7,5	Tubular rivet Ø4x7.5	6									Amarre a base

MOD.

HORNOS A GAS

ZONA

MUEBLE



PLANO

C-1617

ITEM	CODIGO	DENOMINACION	TEXTO	HGC-10 / 21									NOTAS
10	T342805	Cubierta de ducha	Shower cover	1									
	Q012042	Tornillo exagonal M-6x15	Hexagonal screw M-6x15	3									Amarre a base
	Q262040	Arandela grower A-6	Grower washer A-6	3									Amarre a base
	Q232040	Arandela plana A-6	Flat washer A-6	3									Amarre a base
	Q221343	Remache exagonal M-6	Hexagonal rivet M-6	3									Amarre a base
	1100002860	KIT DUCHA HORNO 10 / 21	OVEN SHOWER KIT 10 / 21	1									Bajo pedido
11	Z279506	Grupo ducha mini	Mini shower group	1									Componente kit
	Q152004	Tornillo aplastado M-5x13	Flat screw M-5x13	6									Componente kit
	Q262030	Arandela grower A-5	Grower washer A-5	6									Componente kit
	Q232030	Arandela plana A-5	Flat washer A-5	6									Componente kit
	Q221342	Remache exagonal M-5	Hexagonal rivet M-5	6									Componente kit
12	T302831	Amarre ducha	Shower anchoring	2									Componente kit
	Q012042	Tornillo exagonal M-6x15	Hexagonal screw M-6x15	3									Componente kit
	Q262040	Arandela grower A-6	Grower washer A-6	3									Componente kit
	Q232040	Arandela plana A-6	Flat washer A-6	3									Componente kit
	Q221343	Remache exagonal M-6	Hexagonal rivet M-6	3									Componente kit
13	Q306039	Arandela junta Ø25xØ16,1x1,5	Joint washer Ø25xØ8.5x1.5	1									Componente kit
14	T305067	Entrada de agua a ducha	Shower water inlet	1									Componente kit
15	Q222013	Tuerca 3/4" gas	Nut 3/4" Gas	1									Componente kit
16	Q881302	Abrazadera 12 - 20	Clamp 12 - 20	2									Componente kit
17	3676900	Tubo de goma Ø17xØ10x850	Rubber tubing Ø17xØ10x850	1									Componente kit
18	T345012	Suplemento electrovalvula	Solenoid valve supplement	1									Componente kit
	Q032021	Tornillo alomado M-4x10	Curved screw M-4x10	2									Componente kit
19	Z601114	Manguera entrada de agua	Water inlet hose	1									
	Z701132	Filtro-junta entrada de agua	Filter-joint water inlet	1									
	Q307031	Junta manguera Ø24xØ14x3	Hose joint Ø24xØ14x3	1									

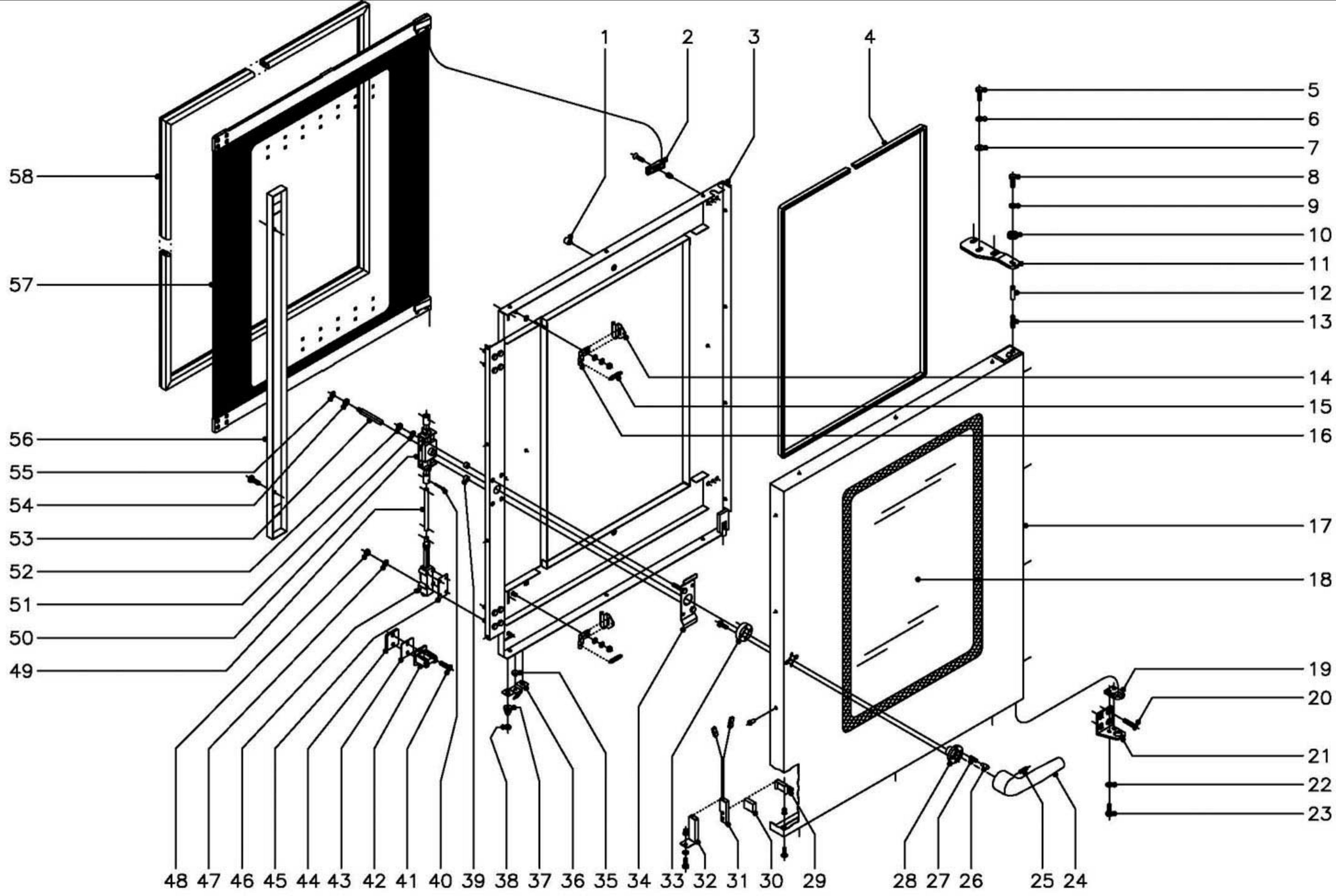
ITEM	CODIGO	DENOMINACION	TEXTO	HGC-10 / 21									NOTAS
20	T302837	Cantonera base	Base corner protector	2									
	Q412002	Remache tubular Ø4x7,5	Tubular rivet Ø4x7.5	8									Amarre a base
21	X260151	Pata regulable	Ajustable leg	4									
	Q012031	Tornillo exagonal M-5x10	Hexagonal screw M-5x10	16									
	Q242030	Arandela abanico A-5	Fan shaped washer A-5	16									
	Q221342	Remache exagonal M-5	Hexagonal rivet M-5	16									
22	T302815	Apoyo cuerpo de horno	Oven body holder	1									
	Q412002	Remache tubular Ø4x7,5	Tubular rivet Ø4x7.5	13									Amarre a base
23	T322801	Base exterior de horno 10 / 21	Oven outer base 10 / 21	1									
24	T302818	Refuerzo longitudinal base	Base longitudinal reinforcen	2									
	Q412002	Remache tubular Ø4x7,5	Tubular rivet Ø4x7.5	32									Amarre a base
25	T302806	Panel exterior izquierdo	Left outer panel	1									
	Q012042	Tornillo exagonal M-6x15	Hexagonal screw M-6x15	3									Amarre inferior
	Q262040	Arandela grower A-6	Grower washer A-6	3									Amarre inferior
	Q232040	Arandela plana A-6	Flat washer A-6	3									Amarre inferior
	Q221343	Remache exagonal M-6	Hexagonal rivet M-6	3									Amarre inferior
26	T322806	Panel portamandos	Control panel	1									
	Q012042	Tornillo exagonal M-6x15	Hexagonal screw M-6x15	3									Amarre inferior
	Q262040	Arandela grower A-6	Grower washer A-6	3									Amarre inferior
	Q232040	Arandela plana A-6	Flat washer A-6	3									Amarre inferior
	Q221343	Remache exagonal M-6	Hexagonal rivet M-6	3									Amarre inferior
	Q412002	Remache tubular Ø4x7,5	Tubular rivet Ø4x7.5	8									Amarre a cuba
27	T343001	Serigrafia HGC-10 / 21	Serigraphy HGC-10 / 21	1									
28	T302834	Canaleta portamandos	Control feed through	1									
	Q012042	Tornillo exagonal M-6x15	Hexagonal screw M-6x15	2									
	Q262040	Arandela grower A-6	Grower washer A-6	2									
	Q232040	Arandela plana A-6	Flat washer A-6	2									
	Q221343	Remache exagonal M-6	Hexagonal rivet M-6	2									
29	T302835	Separador posterior	Rear separator	1									



N plano C-1618	Firma 	Fecha 2-2005	Aparato PUERTA HORNO A GAS HGC-10/21	Lamina 2	Fagor Industrial S.Coop. FAGOR Orate 
-------------------	--	-----------------	--	-------------	--

ITEM	CODIGO	DENOMINACION	TEXTO	HGC-10 / 21									NOTAS
	1100003101	KIT Puerta completa 10/21	Complete door KIT 10/21	1									
1	T300513	Tope cristal interior	Inner glass door stop	6									
2	R670615	Base de bisagra	Hinge base	2									
	Q042032	Tornillo avellanado M-5x15	Countersunk screw M-5x15	2									
	Q222011	Remache exagonal M-5	Hexagonal rivet M-5	2									
3	T300501	Contrapuerta completa	Complete inner door	1									
4	3715200	Junta cristal L=2500	Glass joint L=2500	1									
5	Q012053	Tornillo exagonal M-8x20	Hexagonal screw M-8x20	3									
6	Q242050	Arandela abanico A-8	Fan shaped washer A-8	3									
7	Q302025	Arandela plana Ø8,4x20x1,5	Flat washer Ø8,4x20x1.5	3									
8	Q012042	Tornillo exagonal M-6x15	Hexagonal screw M-6x15	1									
9	Q242040	Arandela abanico A-6	Fan shaped washer A-6	1									
10	R662807	Arandela amarre puerta	Door anchoring washer	1									
11	T300520	Bisagra superior	Upper hinge	1									
12	R660534	Eje superior	Upper shaft	1									
13	Z850519	Resorte	Spring	1									
14	T300514	Pestillo sujecion cristal interior	Inner glass fastening latch	2									
15	R660605	Muelle tensor pestillo	Latch tensor spring	2									
16	R670612	Base de pestillo	Latch base	2									
	Q302022	Arandela plana Ø16xØ6x1,2	Flat washer Ø16xØ6x1.2	2									
	Q242030	Arandela abanico A-5	Fan shaped washer A-5	2									
	Q162030	Tuerca exagonal M-5	Hexagonal nut M-5	2									
17	T300523	Panel puerta completa	Complete door panel	1									
	Q412002	Remache tubular Ø4x7,5	Tubular rivet Ø4x7.5	14									
18	T300505	Cristal exterior	Outer glass	1									
19	R660549	Guia eje inferior	Lower shaft guide	1									
20	Q062040	Tornillo avellanado M-6x16	Countersunk screw M-6x16	4									
21	T300521	Bisagra inferior	Lower hinge	1									

MOD.	HORNOS A GAS	ZONA	PUERTA	PLANO	C-1618
------	--------------	------	--------	-------	--------

ITEM	CODIGO	DENOMINACION	TEXTO	HGC-10 / 21															NOTAS
22	Q242040	Arandela abanico A-6	Fan shaped washer A-6	2															
23	Q012041	Tornillo exagonal M-6x10	Hexagonal screw M-6x10	2															
24	T130502	Manilla	Handle	1															
25	Q132042	Varilla roscada M-6x15	Threaded rod M-6x15	1															
26	T130507	Piton enganche	Fastener spike	2															
27	T130506	Resorte	Spring	2															
28	T130515	Guia manilla	Handle guide	1															
29	T300525	Soporte iman	Magnet holder	1															
30	T300526	Iman	Magnet	1															
31	Z100522	Interruptor magnetico	Magnetic switch	1															
32	T302819	Soporte interruptor magnet. puerta	Door magnetic switch holde	1															
	Q221342	Remache exagonal M-5	Hexagonal rivet M-5	1															
	Q242030	Arandela abanico A-5	Fan shaped washer A-5	1															
	Q152004	Tornillo aplastado M-5x13	Flat screw M-5x13	1															
33	T130514	Soporte resortes	Spring holder	1															
	Q032032	Tornillo alomado M-5x15	Curved screw M-5x15	2															
34	T130511	Suplemento fijacion cerradura	Lock fixing supplement	1															
35	T300518	Tapon cierre canaleta	Feed through closing plug	1															
36	T300517	Chapa cierre canaleta	Feed through closing cover	1															
37	T300524	Resorte conico	Conical spring	2															
38	Q162030	Tuerca exagonal M-5	Hexagonal nut M-5	2															
39	Z608410	Casquillo	Bushing	2															
40	Q352001	Pasador de aletas Ø2x15	Cotter pin Ø2x15	4															
41	Q042045	Tornillo avellanado M-6x30	Countersunk screw M-6x30	4															
42	T110506	Enganche	Fastener	2															
43	R660538	Calzo de enganche	Coupling chock	4															
44	T300519	Suplemento enganche	Fastener supplement	2															
45	T080503	Suplemento elemento cierre	Closing element supplemer	6															
46	T080504	Elemento de cierre	Closing component	2															

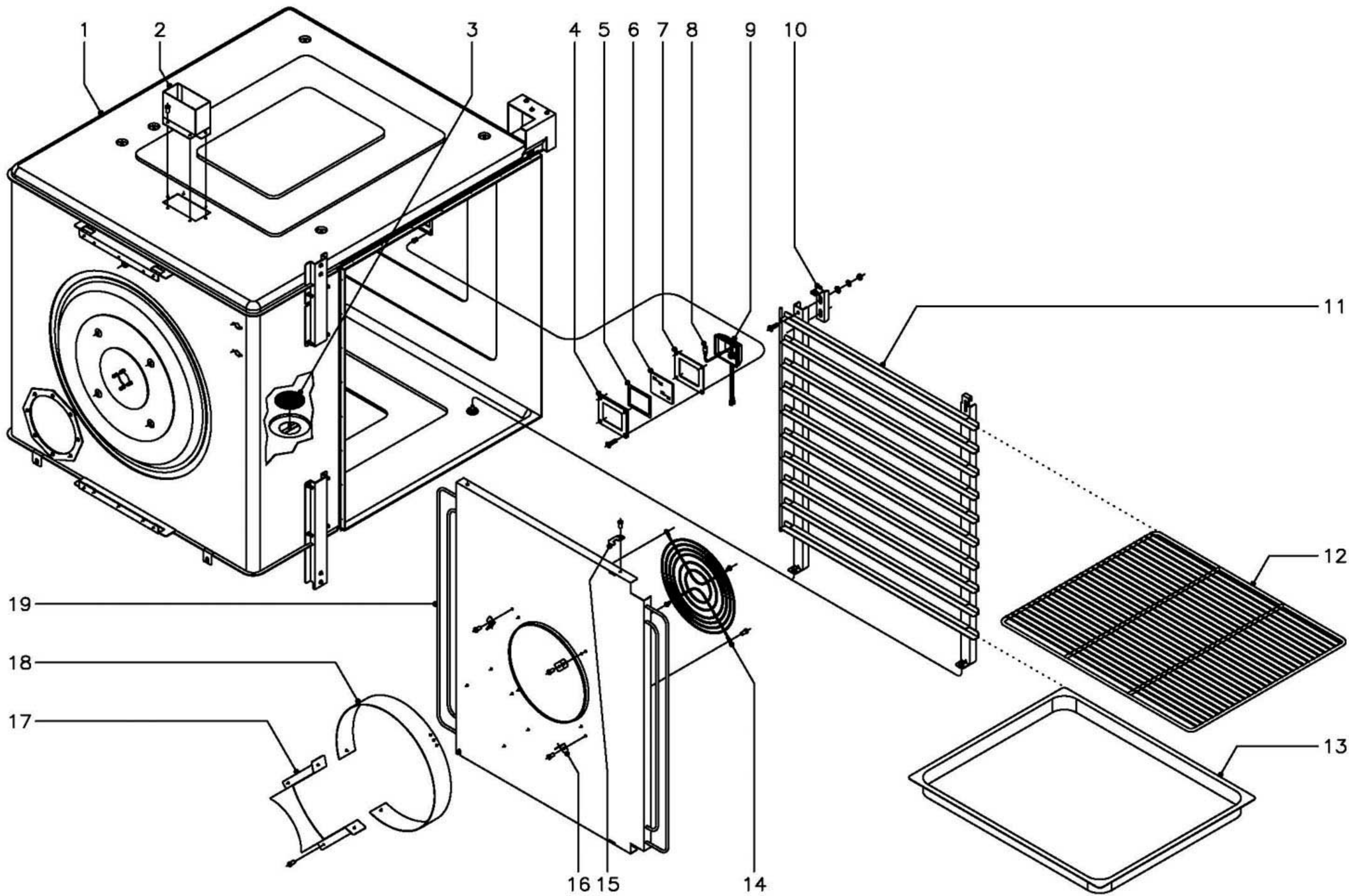

MOD.

HORNOS A GAS

ZONA

MUEBLE INTERIOR

PLANO

C-1619

ITEM	CODIGO	DENOMINACION	TEXTO	HGC-10/21															NOTAS
1	T342600	Cuerpo interior completo	Complete inner body	1															
2	T012605	Chimenea completa	Complete chimney	1															
	Q412002	Remache tubular Ø4x7,5	Tubular rivet Ø4x7.5	6															
3	T302625	Filtro desague completo	Complete waste pipe filter	1															
4	T303047	Pletina amarre lampara	Lamp anchoring platen	1															
	Q042022	Tornillo avellanado M-4x15	Countersunk screw M-4x15	4															
	Q222041	Remache exagonal M-4	Hexagonal rivet M-4	4															
5	T303027	Junta interior lampara	Lamp inner joint	1															
6	T303025	Cristal lampara	Lamp glass	1															
7	T303026	Junta exterior lampara	Lamp outer joint	1															
8	R663013	Lampara 10 W., 12 V.	Lamp 10 W, 12 V	1															
9	T303023	Portalamparas	Lamp holder	1															
10	T302660	Suplemento guias	Guide supplement	2															
	Q152004	Tornillo aplastado M-5x13	Flat screw M-5x13	4															
	Q302022	Arandela plana Ø16xØ6x1,2	Flat washer Ø16xØ6x1.2	4															
	Q242030	Arandela abanico A-5	Fan shaped washer A-5	4															
	Q162030	Tuerca exagonal M-5	Hexagonal nut M-5	4															
11	T302620	Conjunto guias derecho	Right guide set	1															
s/n	T302624	Conjunto guias izquierdo	Left guide set	1															
12	R682676	Parrilla de horno G.N.-2/1	Oven grill G.N.-2/1	1															
13	R032605	Bandeja de horno G.N.-2/1, h=40	Oven tray G.N.-2/1, h=40	1															
14	R662661	Proteccion de turbina	Turbine protection	1															
	Q412002	Remache tubular Ø4x7,5	Tubular rivet Ø4x7.5	4															
15	T302635	Enganche cubreventilador	Fan cover fastener	2															
	Q412002	Remache tubular Ø4x7,5	Tubular rivet Ø4x7.5	2															
16	T302643	Fijacion suplemento cubreventilad.	Fan cover suplement bindin	3															
	Q412002	Remache tubular Ø4x7,5	Tubular rivet Ø4x7.5	3															
17	T342604	Conducto de humos HGC	HCG smoke conduct	1															
	Q412002	Remache tubular Ø4x7,5	Tubular rivet Ø4x7.5	6															

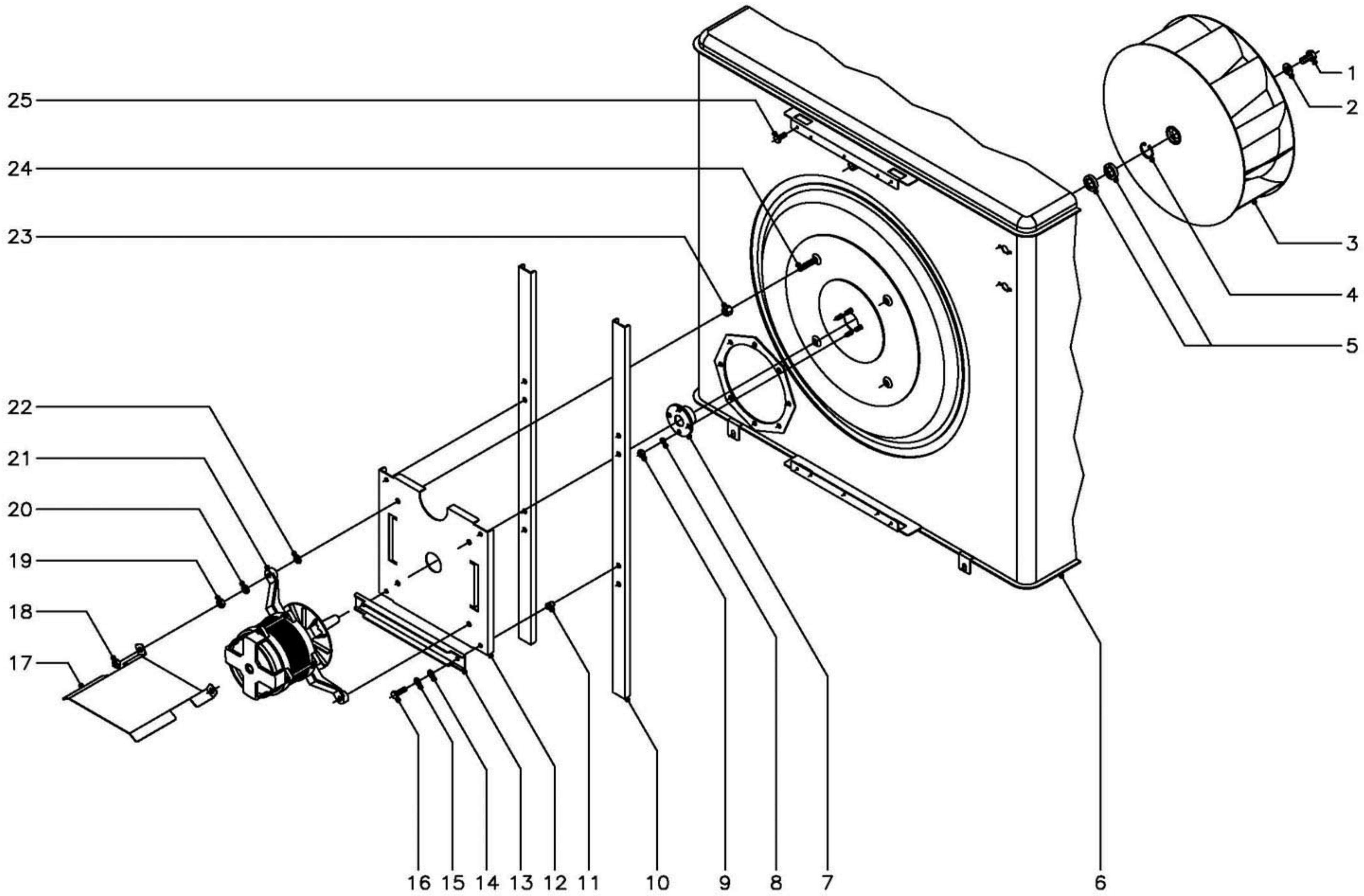

N plano	Firma	Fecha	Aparato	Lamina	Fagor Industrial S.Coop. FAGOR
C-1620		2-2005	TURBINA HORNO A GAS HGC-10/21	4	Orote

MOD.

HORNOS A GAS

ZONA

TURBINA

PLANO

C-1620

ITEM	CODIGO	DENOMINACION	TEXTO	HGC-10 / 21																NOTAS
1	Q012063	Tornillo exagonal M-10x20	Hexagonal screw M-10x20	1																
2	R763010	Arandela seguridad Hanning	Hanning safety washer	1																
3	T303015	Turbina	Turbine	1																
4	Q302023	Anillo de seguridad Ø 28x1,2	Safety ring Ø 28x1.2	1																
5	R662627	Reten Ø 28xØ 17x7	Retainer Ø 28xØ 17x7	2																
6	-	Costado izquierdo de horno	Left side of oven	1																
7	T302629	Casquillo reten	Bushing retainer	1																
8	Q262040	Arandela grower A-6	Grower washer A-6	4																
9	Q162040	Tuerca exagonal M-6	Hexagonal nut M-6	4																
10	T302628	Perfil soporte motor	Motor holder profile	2																
11	Q221342	Remache exagonal M-5	Hexagonal rivet M-5	4																
12	T302627	Soporte motor	Motor holder	1																
13	T302649	Refuerzo motor	Motor reinforcement	2																
14	Q232030	Arandela plana A-5	Flat washer A-5	4																
15	Q242030	Arandela abanico A-5	Fan shaped washer A-5	4																
16	Q012032	Tornillo exagonal M-5x15	Hexagonal screw M-5x15	4																
17	T302665	Tejadillo motor	Motor roof	1																
18	Q162050	Tuerca exagonal M-8	Hexagonal nut M-8	2																
19	Q162050	Tuerca exagonal M-8	Hexagonal nut M-8	4																
20	Q242050	Arandela abanico A-8	Fan shaped washer A-8	4																
21	T323022	Motor de turbina	Turbine motor	1																
22	Q232050	Arandela plana A-8	Flat washer A-8	4																
23	T302638	Distanciador motor	Motor spacer	4																
24	Q012056	Tornillo exagonal M-8x40	Hexagonal screw M-8x40	4																
25	Q012031	Tornillo exagonal M-5x10	Hexagonal screw M-5x10	4																

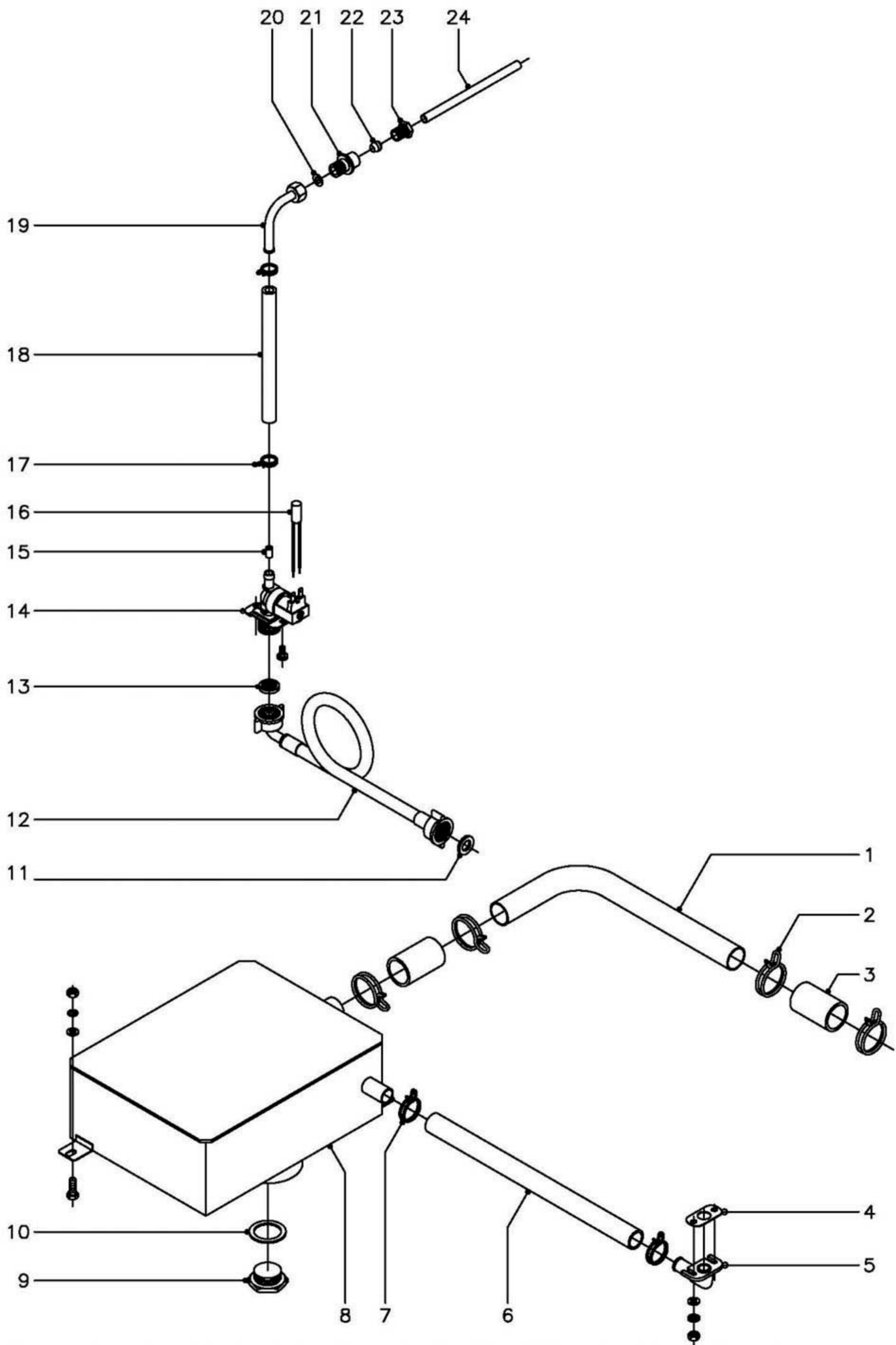

N plano
C-1621

Firma

Fecha
2-2005

Aparato
HORNO A GAS HGC-10/21

CIRCUITO DE AGUA

Lamina
5

Fagor Industrial S.Coop. **FAGOR**
Oñate

MOD.

HORNOS A GAS

ZONA

CIRCUITO DE AGUA

PLANO

C-1621

ITEM	CODIGO	DENOMINACION	TEXTO	HGC-10 / 21																NOTAS
1	T305075	Conducto desagüe horno	Oven drain conduct	1																
2	Q901307	Abrazadera elastica Ø37,7 - 39,7	Elastic clamp Ø26.7 - 39.7	4																
3	3714100	Tubo silicona Ø38xØ31x60	Silicone tubing Ø38xØ31x60	2																
4	T302845	Junta recogeaguas	Water collector joint	1																
5	T302844	Desague recogeaguas	Water collection waste pipe	1																
6	3715600	Tubo recogeaguas Ø26xØ18x600	Water collection tubing Ø26	1																
7	Q901311	Abrazadera elastica Ø26,7 - 28,1	Elastic clamp Ø26.7 - 28.1	2																
8	T345013	Caja desagüe completa	Complete drainage box	1																
	Q012042	Tornillo exagonal M-6x15	Hexagonal screw M-6x15	2																
	Q232040	Arandela plana A-6	Flat washer A-6	2																
	Q262040	Arandela grower A-6	Grower washer A-6	2																
	Q162040	Tuerca exagonal M-6	Hexagonal nut M-6	2																
9	T305052	Tapon desagüe	Waste pipe plug	1																
10	T305053	Junta desagüe	Waste pipe joint	1																
11	Q307031	Junta manguera Ø24xØ14x3	Hose joint Ø24xØ14x3	1																
12	Z601114	Manguera entrada de agua	Water inlet hose	1																
13	Z701132	Filtro-junta entrada de agua	Filter-joint water inlet	1																
14	Z701135	Electrovalvula entrada de agua	Water inlet solenoide valve	1																
	Q153021	Tornillo alomado M-4x10	Curved screw M-4x10	2																
15	R715011	Regulador caudal 0,5 l./min. (naranja)	Flow regulator 0.5 l/min (orange)	1																
16	Z233012	Condensador antiparasitario	Antiparasistic condensor	1																
17	Q901310	Abrazadera elastica Ø16,8 - 17,7	Elastic clamp Ø16.8 - 17.7	2																
18	3676900	Tubo goma negra Ø17xØ10x850	Black rubber tubing Ø17xØ10	1																
19	R695017	Tubo conduccion agua completo	Complete water conduction	1																
20	Q306026	Arandela junta Ø14xØ8,5x1,5	Joint washer Ø14xØ8.5x1.5	1																
21	-	Casquillo soldado a cuerpo horno	Bushing welded onto oven body	1																
22	R695004	Bicono	Bicone	1																
23	R695003	Manguito cierre	Closing sleeve	1																
24	R665024	Tubo conduccion inyector	Injector conduction tubing	1																

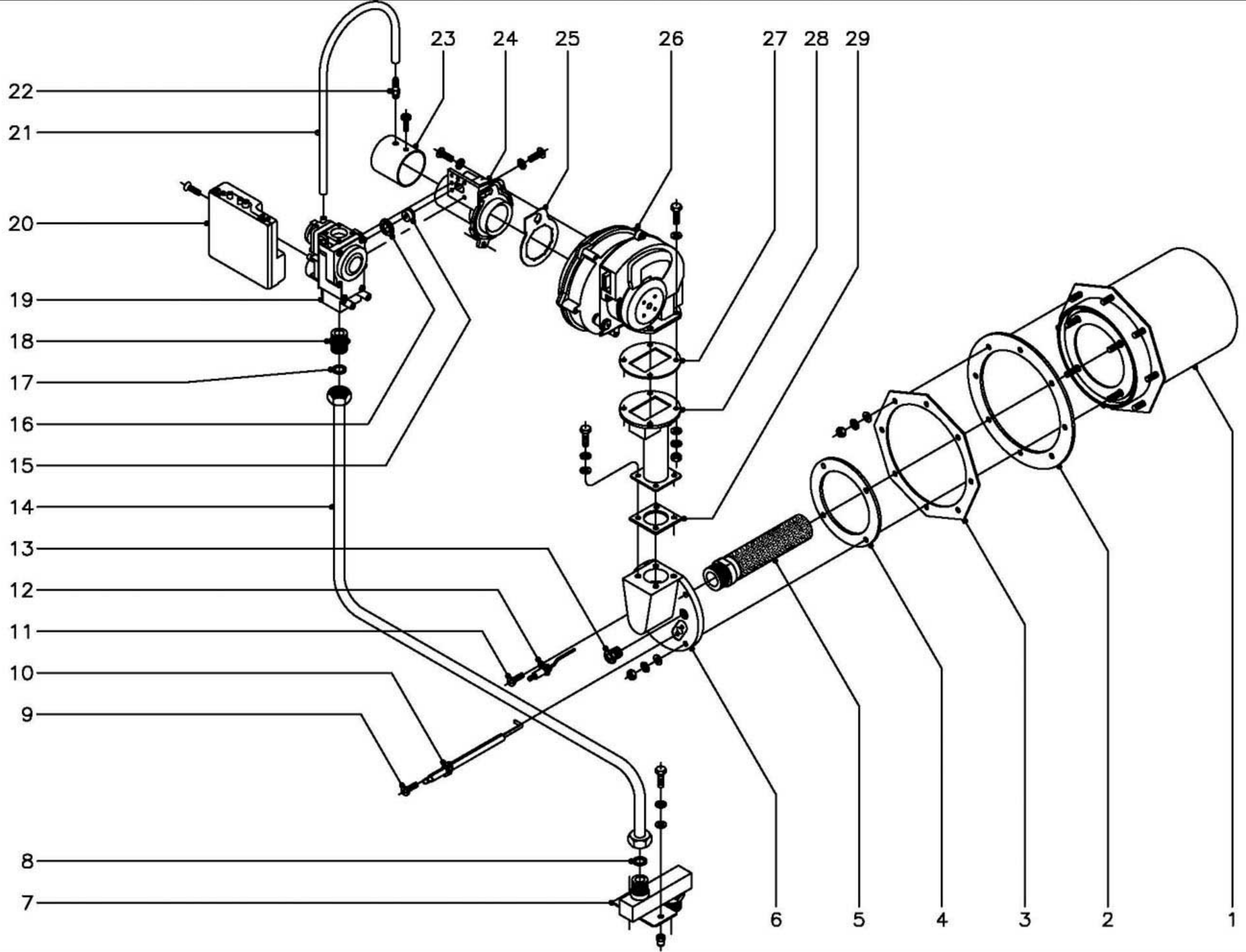

N plano	Firma	Fecha	Aparato	PARTE FUNCIONAL GAS	Lamina	Fagor Industrial S.Coop. FAGOR
C-1622		2-2005	HORNO A GAS HGC-10/21	6	Oñate	

ITEM	CODIGO	DENOMINACION	TEXTO	HGC-10 / 21									NOTAS
1	T345701	Camara combustion completa	Complete combustion cham	1									
2	R725051	Junta camara combustion	Combustion chamber joint	1									
3	-	Brida amarre camara combustion	Combustion chamber ancho	1									Caldeado a cuerpo de horno
	Q232040	Arandela plana A-6	Flat washer A-6	8									
	Q262040	Arandela grower A-6	Grower washer A-6	8									
	Q163040	Tuerca exagonal M-6	Hexagonal nut M-6	8									
4	R725055	Junta de tapa principal	Main cover joint	1									
5	T115710	Quemador Furigas	Furigas burner	1									
6	T115782	Tapa principal	Main cover	1									
	Q232040	Arandela plana A-6	Flat washer A-6	4									Amarre tapa-camara combustion
	Q242030	Arandela abanico A-6	Fan shaped washer A-6	4									Amarre tapa-camara combustion
	Q163040	Tuerca exagonal M-6	Hexagonal nut M-6	4									Amarre tapa-camara combustion
7	T345005	Entrada de gas completa	Complete gas inlet	1									
	Q012032	Tornillo exagonal M-5x15	Hexagonal screw M-5x15	2									
	Q242030	Arandela abanico A-5	Fan shaped washer A-5	2									
	Q232030	Arandela plana A-5	Flat washer A-5	2									
	Q221342	Remache exagonal M-5	Hexagonal rivet M-5	2									
8	Q306012	Arandela junta Ø18xØ13x1,5	Joint washer Ø18xØ13x1.5	1									
9	Q153021	Tornillo alomado M-4x10	Curved screw M-4x10	2									
10	T115781	Electrodo de ignicion	Ignition electrode	1									
11	Q153021	Tornillo alomado M-4x10	Curved screw M-4x10	1									
12	T115712	Electrodo de deteccion	Detection electrode	1									
13	R725015	Visor de encendido	Ignition sight	1									
14	T345008	Conduccion a valvula completa	Complete valve conduction	1									
15	T305068	Tobera VK41, Ø4,8 (Buta.-Propa.)	Nozzle VK41, Ø4.8 (Buta.-P	1									
15	T305069	Tobera VK41, Ø6 (Gas Natural)	Nozzle VK41, Ø6 (Natural	1									
16	T303046	Junta venturi 24x15,5	Venturi joint 24x150.5	1									
17	Q306012	Arandela junta Ø18xØ13x1,5	Joint washer Ø18xØ13x1.5	1									
18	S205023	Manguito doble 1/2"	Double sleeve 1/2"	1									

MOD.	HORNOS A GAS		ZONA	PARTE FUNCIONAL GAS							PLANO	C-1622
ITEM	CODIGO	DENOMINACION	TEXTO	HGC-10 / 21								NOTAS
19	T303017	Valvula VK-4115 V-1121	Valve VK-4115 V-1121	1								
	Q242030	Arandela abanico A-5	Fan shaped washer A-5	3								
	Q152004	Tornillo aplastado M-5x13	Flat screw M-5x13	3								
20	T303013	Control de encendido	Ignition control	1								
	Q032011	Tornillo alomado M-3x10	Curved screw M-3x10	1								
21	3702400	Tubo goma negra Ø8xØ4x200	Black rubber tubing Ø8xØ4x	1								
22	R725077	Boquilla conexión	Connection nozzle	1								
23	T305712	Tubo ventilador completo	Complete ventilating tubing	1								
	Q032021	Tornillo alomado M-4x10	Curved screw M-4x10	1								
24	T303040	Venturi	Venturi	1								
25	-	Junta venturi-ventilador	Venturi-fan joint	1								Viene con venturi
	Q242030	Arandela abanico A-5	Fan shaped washer A-5	2								
	Q152004	Tornillo aplastado M-5x13	Flat screw M-5x13	2								
26	T303016	Ventilador RG-130	Fan RG-130	1								
	Q012043	Tornillo exagonal M-6x20	Hexagonal screw M-6x20	4								Amarre ventilador-conduccion
	Q232040	Arandela plana A-6	Flat washer A-6	8								Amarre ventilador-conduccion
	Q242030	Arandela abanico A-6	Fan shaped washer A-6	4								Amarre ventilador-conduccion
	Q163040	Tuerca exagonal M-6	Hexagonal nut M-6	4								Amarre ventilador-conduccion
27	T305042	Junta ventilador	Fan joint	1								
28	T345000	Conducto a tapa principal compl.	Complete conduct to main c	1								
	Q012032	Tornillo exagonal M-5x15	Hexagonal screw M-5x15	4								Amarre conduccion a tapa principal
	Q242030	Arandela abanico A-5	Fan shaped washer A-5	4								Amarre conduccion a tapa principal
	Q232030	Arandela plana A-5	Flat washer A-5	4								Amarre conduccion a tapa principal
29	T305041	Junta tapa principal-conducto	Main cover-conduct joint	1								

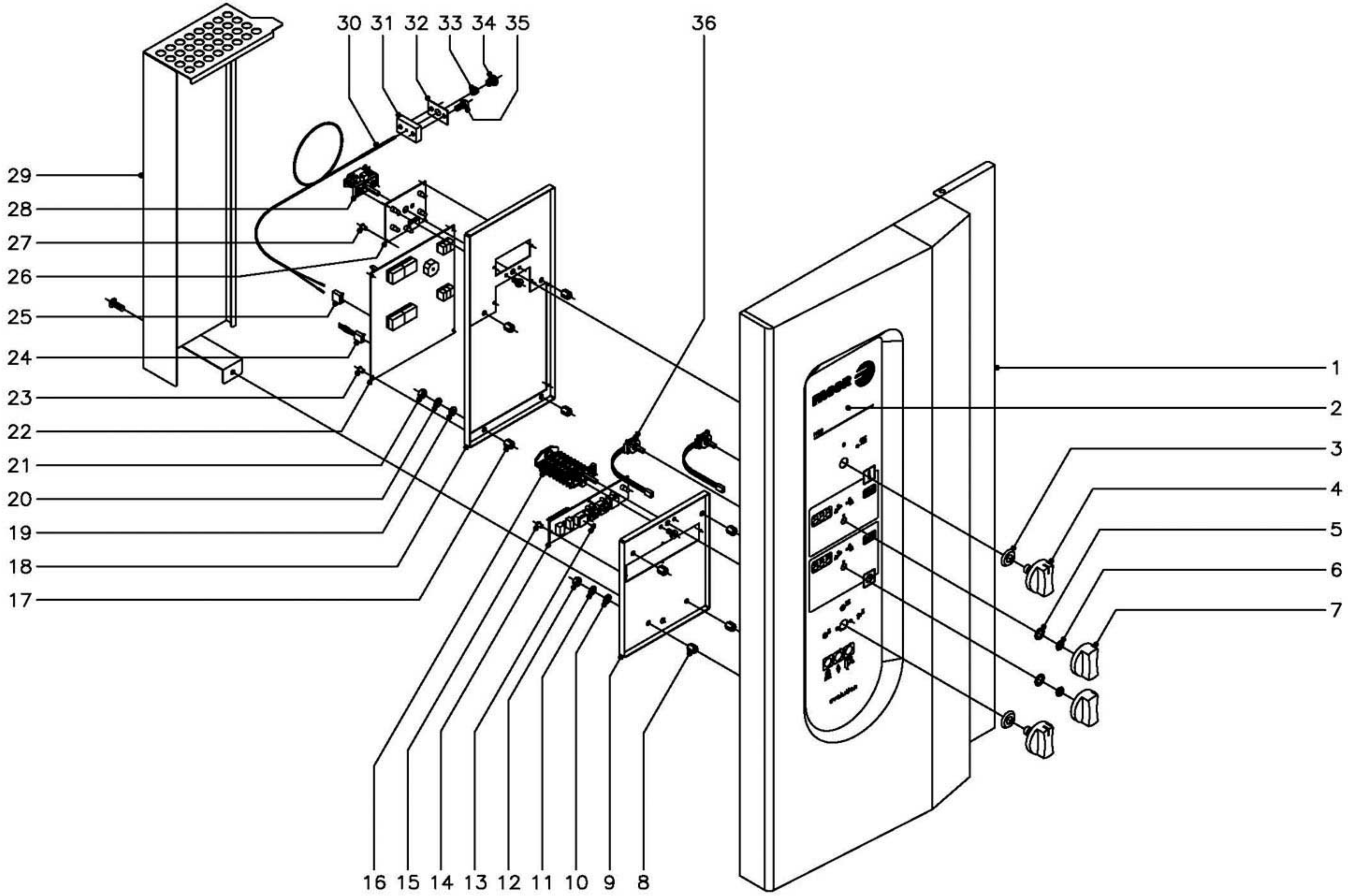

N plano C-1623	Firma 	Fecha 2-2005	Aparato PARTE ELECTRICA PORTAMANDOS HORNO A GAS HGC-10/21	Lamina 7	Fagor Industrial S.Coop. FAGOR Orate
-------------------	-----------	-----------------	---	-------------	--

MOD.

HORNOS A GAS

ZONA

PARTE ELECTRICA PORTAMANDOS

PLANO

C-1623

ITEM	CODIGO	DENOMINACION	TEXTO	HGC-10 / 21																NOTAS
1	T322806	Panel portamandos	Control panel	1																
2	T343001	Serigrafia HGC-10 / 21	Serigraphy HGC-10 / 21	1																
3	R663046	Junta conmutador	Switch joint	2																
4	T303010	Boton de mando completo	Complete control button	2																
5	-	Arandela (viene con tuerca M-10)	Washer (comes with M-10 n	2																
6	Z953041	Tuerca exagonal M-10	Hexagonal nut M-10	2																
7	T303011	Boton de mando completo	Complete control button	2																
8	T302829	Distanciador componentes	Components spacer	4																
9	T303021	Soporte circuitos	Circuit holder	1																
10	Q232030	Arandela plana A-5	Flat washer A-5	4																
11	Q242030	Arandela abanico A-5	Fan shaped washer A-5	4																
12	Q163030	Tuerca exagonal M-5	Hexagonal nut M-5	4																
13	R663056	Bapipons autoadesivo	Self adhesive bupipons	3																
14	T303019	Circuito teclado	Key board circuit	1																
15	R663036	Fijacion circuito	Circuit bindings	4																
16	R663026	Conmutador de funciones	Function switch	1																
	Q151320	Tornillo alomado M-4x6	Curved screw M-4x6	2																
17	T302829	Distanciador componentes	Components spacer	4																
18	T302826	Soporte componentes	Components holder	1																
19	Q232030	Arandela plana A-5	Flat washer A-5	4																
20	Q242030	Arandela abanico A-5	Fan shaped washer A-5	4																
21	Q163030	Tuerca exagonal M-5	Hexagonal nut M-5	4																
22	T353003	Controlador	Controller	1																
23	R663036	Fijacion circuito	Circuit bindings	4																
24	T343007	Resistencia selec. modo convecc.	Convecc. mode selec. resis	1																
25	T343005	Conector 4 vias	4 way connector	1																
26	T303018	Circuito de leds visualizador	Display leds circuit	1																
27	R663036	Fijacion circuito	Circuit bindings	4																
28	T343008	Interruptor general	General switch	1																

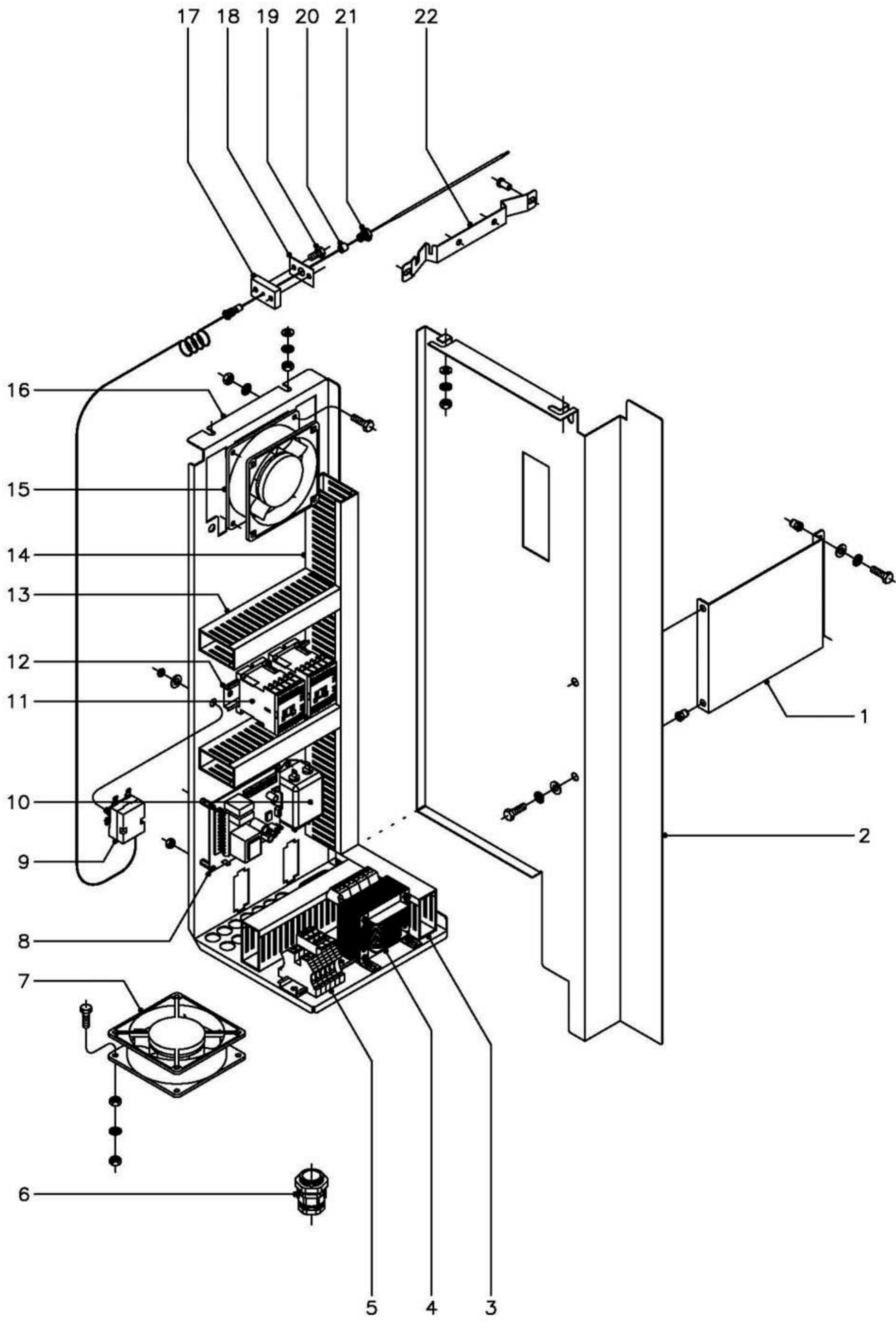

N plano
C-1624

Firma

Fecha
2-2005

Aparato
CUADRO ELECTRICO
HORNO A GAS HGC-10/21

Lamina
8

Fagor Industrial S.Coop. **FAGOR**
Ofite

MOD.

HORNOS A GAS

ZONA

CUADRO ELECTRICO

PLANO

C-1624

ITEM	CODIGO	DENOMINACION	TEXTO	HGC-10 / 21										NOTAS
1	T303051	Soporte cierre cuadro electrico	Switchboard closing holder	1										
	Q012032	Tornillo exagonal M-5x15	Hexagonal screw M-5x15	2										
	Q242030	Arandela abanico A-5	Fan shaped washer A-5	2										
	Q302022	Arandela plana Ø16xØ6x1,2	Flat washer Ø16xØ6x1.2	2										
	Q221342	Remache exagonal M-5	Hexagonal rivet M-5	2										
2	T323003	Cierre cuadro electrico	Switchboard closing	1										
	Q012032	Tornillo exagonal M-5x15	Hexagonal screw M-5x15	2										Amarre cierre a soporte
	Q242030	Arandela abanico A-5	Fan shaped washer A-5	2										Amarre cierre a soporte
	Q302022	Arandela plana Ø16xØ6x1,2	Flat washer Ø16xØ6x1.2	2										Amarre cierre a soporte
	Q221342	Remache exagonal M-5	Hexagonal rivet M-5	2										Amarre cierre a soporte
	Q302022	Arandela plana Ø16xØ6x1,2	lat washer Ø16xØ6x1.2	2										Amarre cierre a techo
	Q242030	Arandela abanico A-6	Fan shaped washer A-6	2										Amarre cierre a techo
	Q163040	Tuerca exagonal M-6	Hexagonal nut M-6	2										Amarre cierre a techo
3	3715520	Canaleta unex 30x60x150	Unex feed through 30x60x1	1										
	Q412002	Remache tubular Ø4x7,5	Tubular rivet Ø4x7.5	2										
4	R503005	Transformador	Transformer	1										
	Q032021	Tornillo alomado M-4x10	Curved screw M-4x10	4										
	Q242020	Arandela abanico A-4	Fan shaped washer A-4	4										
	Q162020	Tuerca exagonal M-4	Hexagonal nut M-4	4										
5	Z263303	Tope final 10	End buffer 10	1										
	R073005	Borna portafusible	Fuse carrier connection	3										
	P184011	Cartucho portafusible 4A.	Fuse holder cartridge 4A.	3										
	Z263302	Borne paso 10 azul	Blue connector lead 10 blue	1										
	P453026	Borne tierra 10 amarillo-verde	Earth connector 10 yellow-g	1										
	Z403016	Guia contactor L=100	Contacto guide G=100	1										
	Q412002	Remache tubular Ø4x7,5	Tubular rivet Ø4x7.5	2										
6	R073004	prensaestopas	Stuffing box	1										
7	Z103066	Ventilador 230V., 50/60 Hz.	Fan 230 V, 50/60 Hz	1										
	Q013023	Tornillo exagonal M-4x20	Hexagonal screw M-4x20	4										

ITEM	CODIGO	DENOMINACION	TEXTO	HGC-10/21									NOTAS
	Q242020	Arandela abanico A-4	Fan shaped washer A-4	4									
	Q162020	Tuerca exagonal M-4	Hexagonal nut M-4	8									
8	T303048	Variador hornos gas 4V	4V gas ovens variator	1									
	T133007	Distanciador M-3	Spacer M-3	4									
	T133008	Tornillo amarre M-3x22	Anchoring screw M-3x22	4									
	Q161310	Tuerca exagonal M-3	Hexagonal nut M-3	4									
9	T303009	Termostato limitador	Limiter thermostat	1									
	Q232050	Arandela plana A-8	Flat washer A-8	1									
	Q162050	Tuerca exagonal M-8	Hexagonal nut M-8	1									
10	T113023	Filtro de entrada	Inlet filter	1									
11	Z743009	Contactador sirius 3RT10, 16-2APO2	Sirius 3RT10, 16-2APO2 co	2									
12	Z103084	Guia contactor L=138	Contactador guide G=138	1									
	Q412002	Remache tubular Ø4x7,5	Tubular rivet Ø4x7.5	2									
13	3715520	Canaleta unex 30x60x180	Unex feed through 30x60x1	3									
	Q412002	Remache tubular Ø4x7,5	Tubular rivet Ø4x7.5	6									
14	3715520	Canaleta unex 30x60x510	Unex feed through 30x60x5	1									
	Q412002	Remache tubular Ø4x7,5	Tubular rivet Ø4x7.5	3									
15	Z103066	Ventilador 230V., 50/60 Hz.	Fan 230 V, 50/60 Hz	1									
	Q012021	Tornillo exagonal M-4x10	Hexagonal screw M-4x10	4									
	Q242020	Arandela abanico A-4	Fan shaped washer A-4	4									
	Q162020	Tuerca exagonal M-4	Hexagonal nut M-4	4									
16	T323004	Panel cuadro electrico	Switchboard panel	1									
	Q302022	Arandela plana Ø16xØ6x1,2	Flat washer Ø16xØ6x1.2	2									
	Q242030	Arandela abanico A-6	Fan shaped washer A-6	2									
	Q163040	Tuerca exagonal M-6	Hexagonal nut M-6	2									
17	T112625	Base cierre sonda (pasamuros)	Probe closing base (wire pro	1									
18	R692812	Junta pasamuros	Wire protection joint	1									
19	Q012021	Tornillo exagonal M-4x10	Hexagonal screw M-4x10	2									
20	R662662	Junta cierre bulbo limitador	Limiting bulb closing joint	1									

MOD.

HORNOS A GAS

ZONA

VARIOS

PLANO

ITEM

CODIGO

DENOMINACION

TEXTO

HGC-10 / 21

NOTAS

T306500

Manual de instrucciones

Instructions manual

1

Español

T306501

Manual de instrucciones

Instructions manual

1

Aleman

T306502

Manual de instrucciones

Instructions manual

1

Frances

T306503

Manual de instrucciones

Instructions manual

1

Ingles

T306504

Manual de instrucciones

Instructions manual

1

Italiano

T343003

Esquema electrico adhesivo

Adhesive electrical diagram

1

Plano HC-77081

T303042

Leyenda esquema electrico

Electrical diagram legend

1

Plano HC-76970

T343004

Plano electrico de montaje

Assembly electrical diagram

1

Plano HD-12886

T303053

Union contactores de inversion

Inversion contactors joint

1

T303033

Cableado variador - soplante

Variator wiring - blower

1

T303031

Cableado luz interior

Inner light wiring

1

T343006

Cableado control circuito de leds

Leds circuit control wiring

1

T343002

Instalacion electrica HGC-10/21

Electrical installation HGC-10/21

1

T303034

Cable encendido camara

Chamber ignition cable

1

T303035

Cable detector de llama en camara

Chamber flame detector cable

1

HGC 10/11 HGC 10/21

QEASP/ECG-20/11

3 ~ 400V

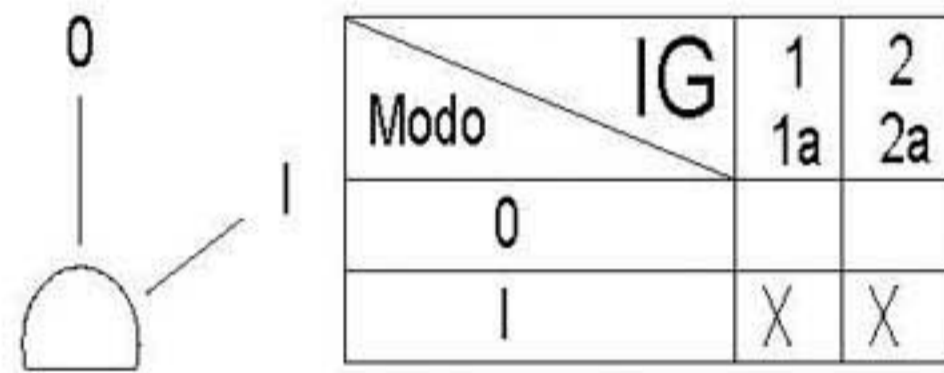
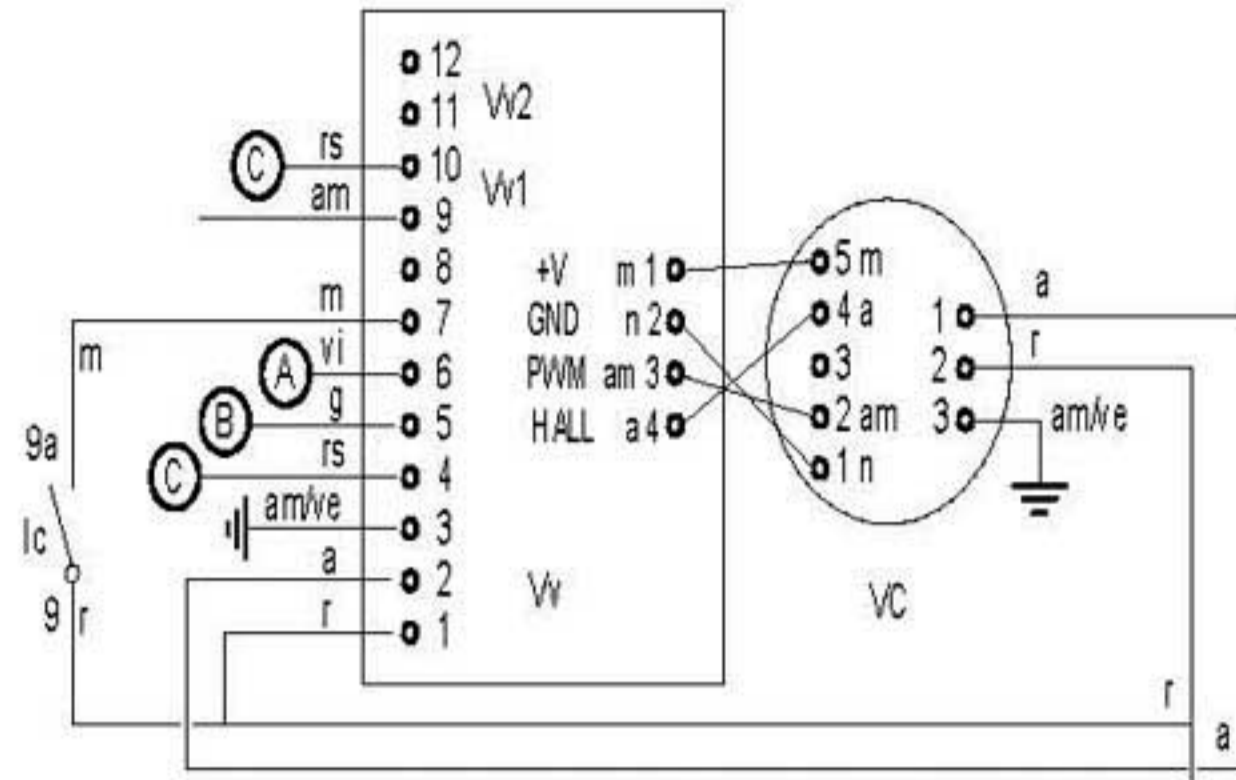
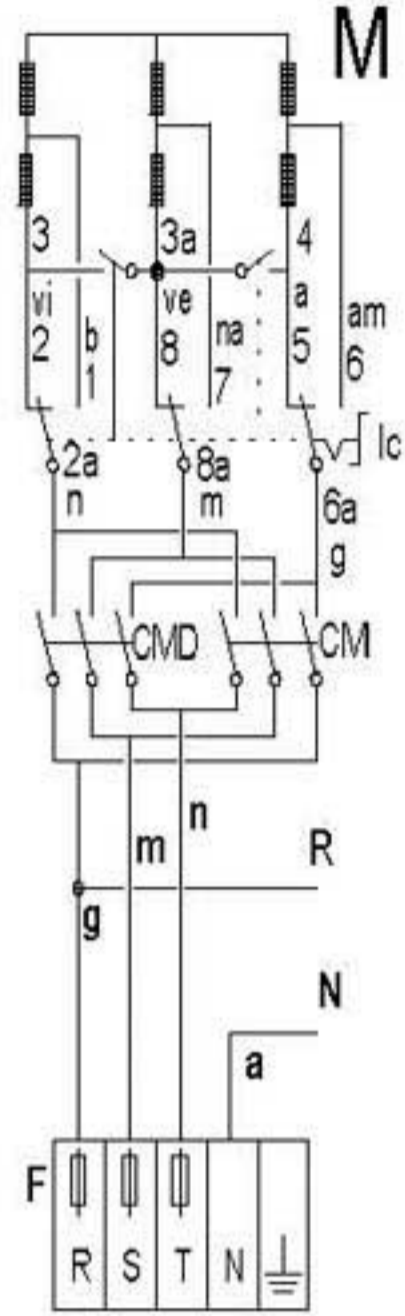

IC	1	2	3	4	5	6	7	8	9
	1a	2a	3a	4a	5a	6a	7a	8a	9a
1	X		X	X		X	X		
2	X		X	X		X	X		X
3		X			X			X	

3 ~ 220V

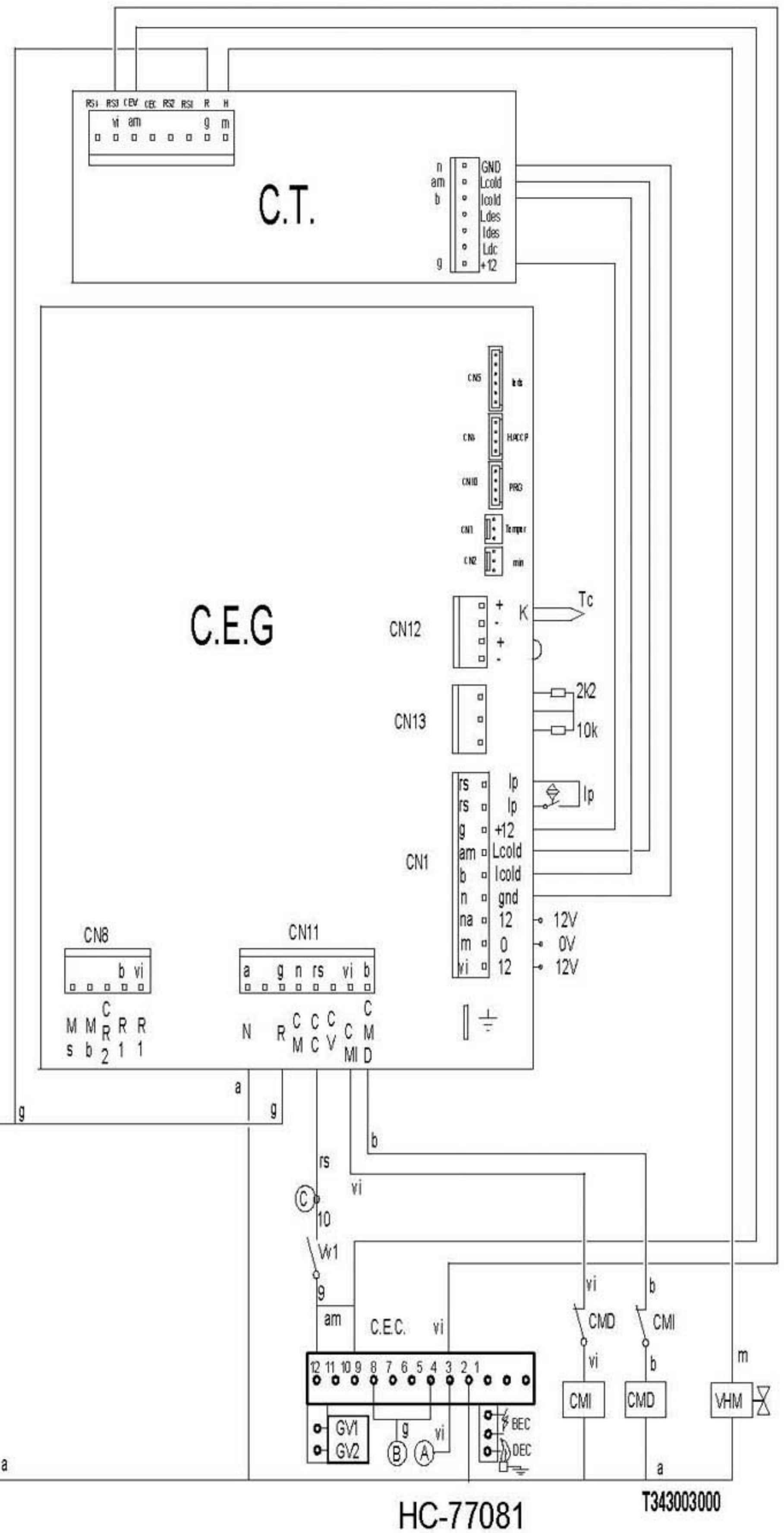
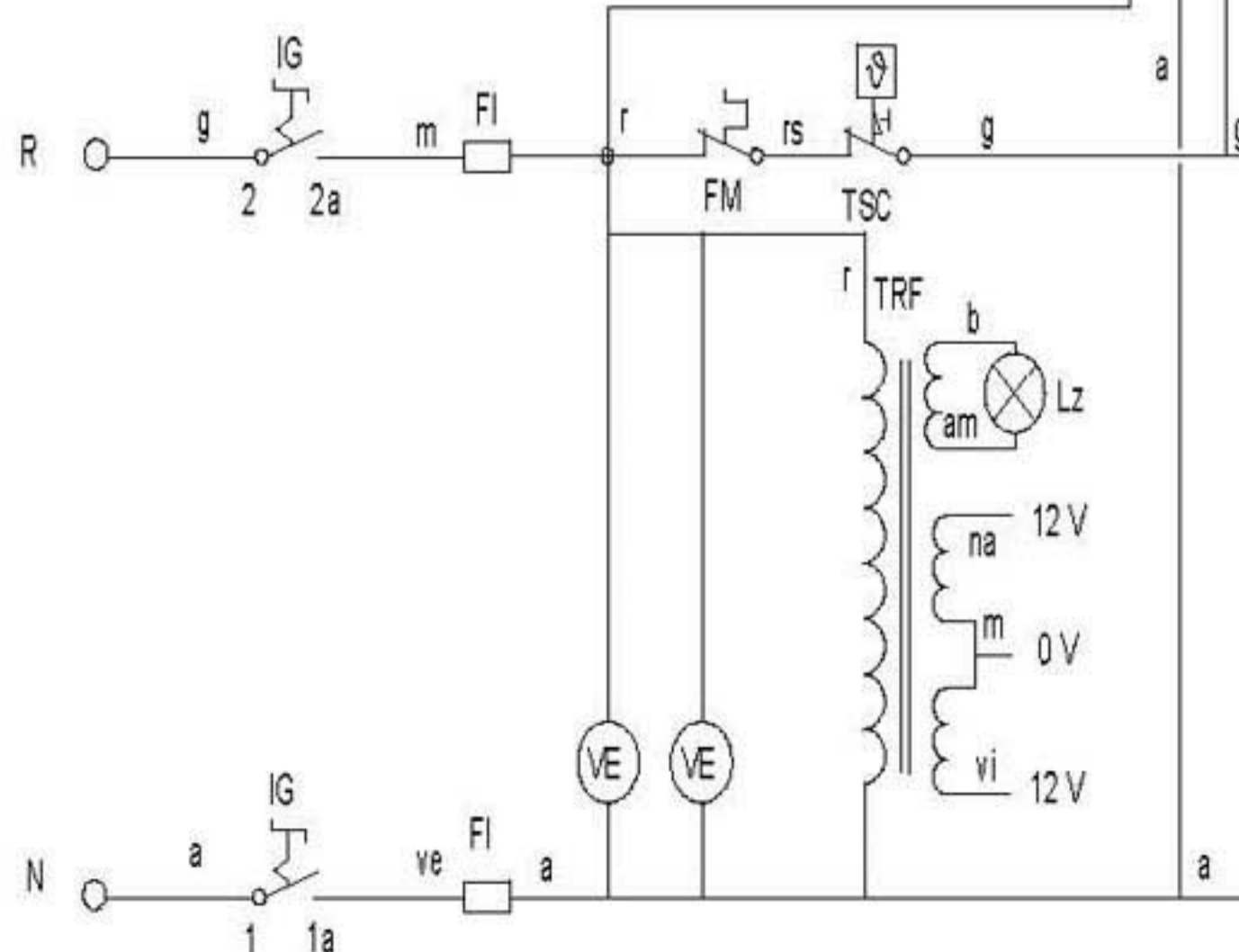
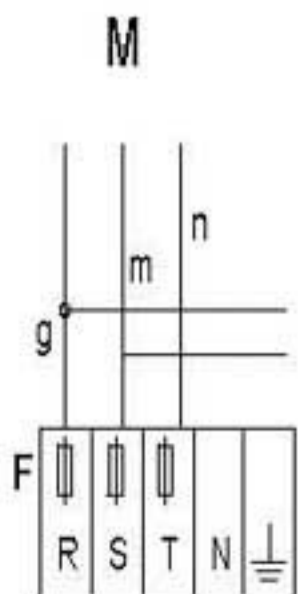

3-50Hz 220V

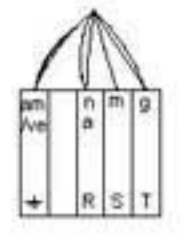

- 1 T-343002
 - 2 T-303033
 - 3 T-303034
 - 4 T-303035
 - 5 T-303036
 - 7 T-303022
 - 8 T-343006
 - 9 T-303029
 - 10 T-303031
 - 11 T-303037
- Esquema teórico T-343003
Leyenda T-303042
Indicador comp. T-303043

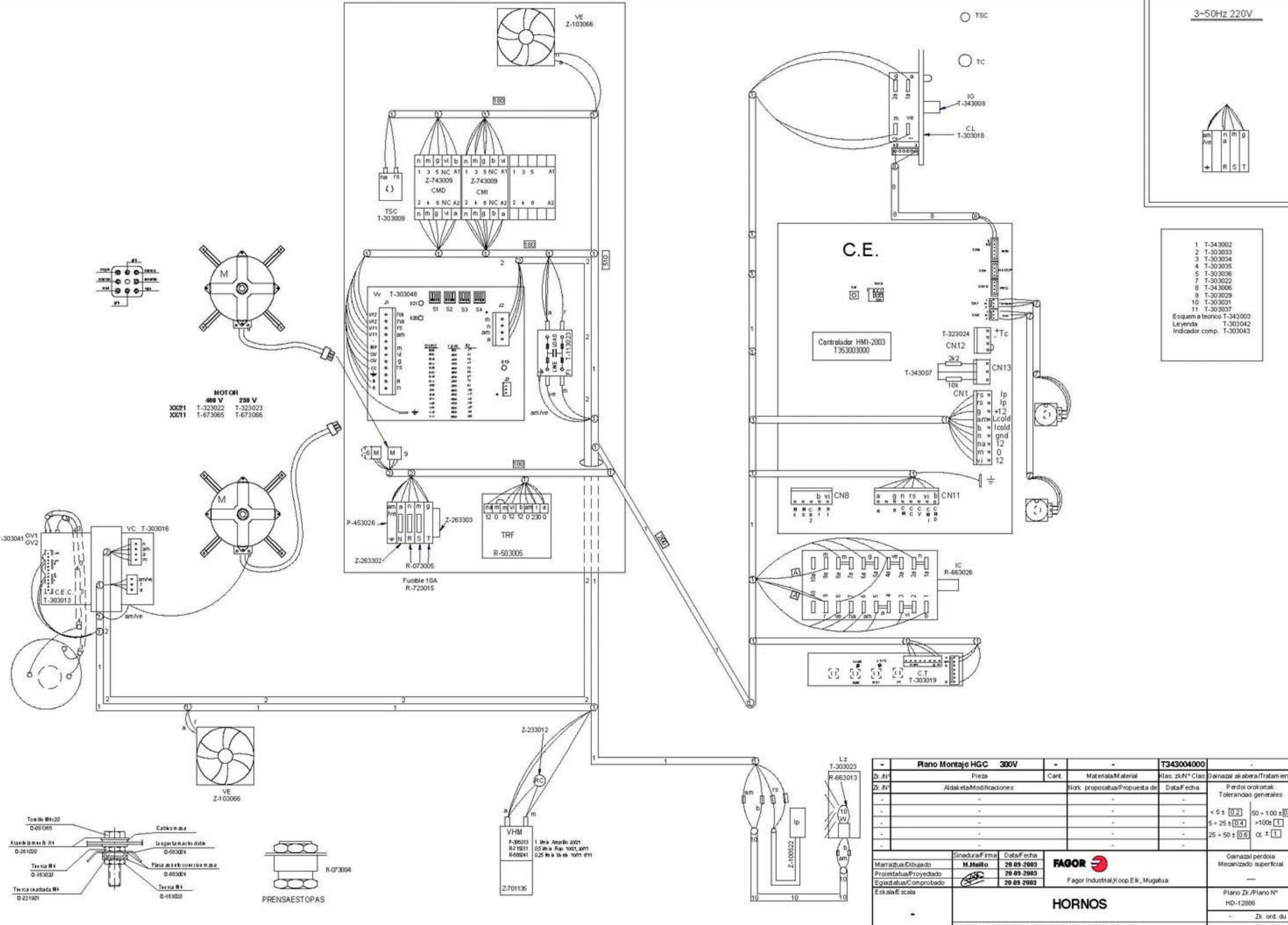

MOTOR
400 V 230 V
XX21 T-323022 T-323023
XX11 T-673065 T-673066

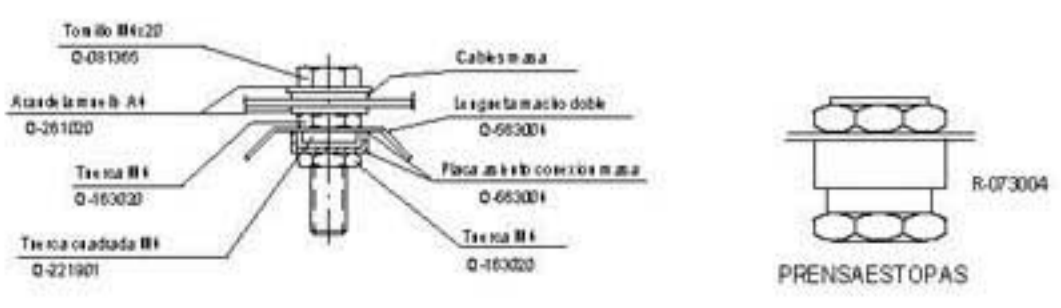

Plano Montaje HGC 300V		T343004000	
Zk. N°	Pieza	Cant.	Material/Material
Zk. N°	Aldaketa/Modificaciones	Egiazapena/Propuesta de	
		Data/Fecha	
		Perdora/okorak	
		Tolerancias generales	
		< 5 ± 0.2	50 ± 1.00 ± 0.2
		5 ± 25 ± 0.4	> 100 ± 1
		25 ± 50 ± 0.6	α ± 1
Sinadura/Firma		Data/Fecha	
Marratza/Dibutad		20 09 2003	
Proiektatua/Proyektado		20 09 2003	
Egiaztapua/Comprobado		20 09 2003	
Eskala/Escala			
FAGOR			
Fagor Industrial, Koop. Elk., Mugatu			
HORNOS			
Plano Zk. /Plano N° HD-12886			
Plano hau edn datetke erabil, ez berrizatu, gure baimenik gabe.			

	ESPAÑOL	FRANÇAIS	ENGLISH	DEUTSCH	ITALIANO
BEC =	Bujía Encendido Cámara	Bougie Allumage Chambre	Chamber Spark Plug	Zündkerze Einschalten Garraum	Candela di Accensione Camera
BEV =	Bujía Encendido Caldera	Bougie Allumage Chaudière	Boiler Spark Plug	Zündkerze Einschalten Boile	Candela di Accensione Caldaia
C.E.C =	Control Combustión Cámara	Contrôle Combustion Chambre	Chamber Combustion Control	Steuerung Verbrennung Garraum	Controllo Combustione Camera
C.E.G =	Control Electrónico General	Contrôle Électronique Général	Main Electronic Control	Steuerung Elektronik allgemein	Controllo Elettronico Generale
C.E.V =	Control Combustión Caldera	Contrôle Combustion Chaudière	Boiler Combustion Control	Steuerung Verbrennung Boiler	Controllo Combustione Caldaia
C.H =	Circuito Humedad	Circuit Humidité	Humidity Circuit	Kreislauf Feuchtigkeit	Circuito Umidità
C.L =	Circuito Leds	Circuit LEDs	Led Circuit	Kreislauf LEDs	Circuito Leds
C.T =	Circuito Teclado	Circuit Clavier	Keypad Circuit	Kreislauf Tastatur	Cicuito Tastiera
CC1,CC2 =	Contactador Resistencia Cámara	Contacteur Élément Chauffant Chambre	Chamber Heating Element Contactor	Schutz Heizwiderstand Garraum	Contattore Resistenza Camera
CMD =	Contactador Motor Derecha	Contacteur Moteur Droite	Right Engine Contactor	Schutz Motor rechts	Contattore Motore Destra
CM =	Contactador Motor Izquierda	Contacteur Moteur Gauche	Left Engine Contactor	Schutz Motor links	Contattore Motore Sinistra
CR2 =	Rele Arranque	Relais Démarrage	Starting Relay	Relais Anlauf	Relè Accensione
CV1, CV2 =	Contactador Resistencias Caldera	Contacteur Élément Chauffant Chaudière	Boiler Heating Element Contactor	Schutz Heizwiderstand Boiler	Contattore Resistenza Caldaia
DEC =	Detector Llama Cámara	Détecteur Flamme Chambre	Chamber Flame Detector	Flammendetektor Garraum	Rilevatore di Fiamma Camera
DEV =	Detector Llama Caldera	Détecteur Flamme Chaudière	Boiler Flame Detector	Flammendetektor Boiler	Rilevatore di Fiamma Caldaia
DN =	Detector Nivel Caldera	Détecteur Niveau Chaudière	Boiler Level Detector	Pegeldetektor Boiler	Rilevatore Livello Caldaia
EM =	Encoder Selector Tiempo	Encodeur Sélecteur Temps	Time Selector Encoder	Encoder Zeitwahlschalter	Encoder Selettore Tempo
E°C =	Encoder Selector Temperatura	Encodeur Sélecteur Température	Temperature Selector Encoder	Encoder Temperaturwahlschalter	Encoder Selettore Temperatura
F =	Fusibles	Fusibles	Fuses	Sicherungen	Fusibili
FI =	Filtro Interferencias	Filtre Interférences	Interference Filter	Störungsfilter	Filtro Interferenze
FM =	Térmico Motor	Thermique Moteur	Thermal Engine	Thermoschalter Motor	Termico Motore
GV1, GV2 =	Electro válvula Gas Cámara	Électrovanne Gaz Chambre	Chamber Gas Solenoid Valve	Elektroventil Gas Garraum	Elettrovalvola Gas Camera
GV3, GV4 =	Electro válvula Gas Caldera	Électrovanne Gaz Chaudière	Boiler Gas Solenoid Valve	Elektroventil Gas Boiler	Elettrovalvola Gas Caldaia
IC =	Selector Velocidad Potencia	Sélecteur Vitesse Puissance	Power Speed Selector	Wahlschalter Geschwindigkeit Leistung	Selettore Velocità Potenza
IG =	Interruptor General	Interrupteur Général	Main Switch	Hauptschalter	Interruttore generale
IL =	Interruptor Seguridad Lavado	Interrupteur Sécurité Lavage	Washing Safety Switch	Sicherheitsschalter Waschen	Interruttore Sicurezza Lavaggio
Ip =	Interruptor Seguridad Puerta	Interrupteur Sécurité Porte	Door Safety Switch	Sicherheitsschalter Tür	Interruttore Sicurezza Porta
K1,K2,CK1,CK2=	Rele Resistencia	Relais Élément Chauffant	Heating Element Relay	Relais Heizwiderstand	Relè Resistenza
Lz =	Luz Interior	Éclairage Intérieur	Inner Light	Innenbeleuchtung	Luce Interna
M, M1, M2 =	Motor Turbina	Moteur Turbine	Turbine Engine	Motor Turbine	Motore Turbina
Mch =	Motor Chimenea	Moteur Cheminée	Stack Engine	Motor Abluftkamin	Motore Canna
Md =	Motor Válvula	Moteur vanne	Valve Engine	Motor Ventil	Motore Valvola
MBA =	Bomba Lavado	Pompe Lavage	Washing Pump	Waschenpumpe	Pompa lavaggio
Mb =	Interruptor Micro Bajada	Micronrupteur Descente	Drop Microswitch	Mikroschalter Senken	Interruttore Micro Discesa
Ms =	Interruptor Micro Subida	Micronrupteur Montée	Rise Microswitch	Mikroschalter Heben	Interruttore Micro Salita
PF =	Potenciómetro Selector Funciones	Potentiomètre Sélecteur Fonctions	Functions Selector Potentiometer	Potentiometer Funktionswahlschalter	Potenziometro Selettore Funzioni
PRG =	Programador	Programateur	Programmer	Programmiervorrichtung	Programmatore
RC =	Resistencias Cámara	Éléments Chauffants Chambre	Chamber Heating Element	Heizwiderstände Garraum	Resistenze Camere
RV =	Resistencias Caldera	Éléments Chauffants Chaudière	Boiler Heating Element	Heizwiderstände Boiler	Resistenze Caldaia
Tc =	Sonda Cámara	Sonde Chambre	Chamber Probe	Sonde Garraum	Sonda Camera
TCN =	Termostato Condensación	Thermostat Condensation	Condensation Thermostat	Thermostat Kondensierung	Termostato Condensazione
Tg =	Sonda Caldera	Sonde Chaudière	Boiler Probe	Sonde Boiler	Sonda Caldaia
TH =	Sonda Humedad	Sonde Humidité	Humidity Probe	Sonde Feuchtigkeit	Sonda Umidità
Tn =	Sonda Núcleo	Sonde Noyau	Core Probe	Kerntemperaturmesssonde	Sonda Nucleo
TRF =	Transformador	Transformateur	Transformer	Transformator	Trasformatore
TSC =	Termostato Seguridad Cámara	Thermostat Sécurité Chambre	Chamber Safety Thermostat	Sicherheitsthermostat Garraum	Termostato Sicurezza Camera
TSV =	Termostato Seguridad Caldera	Thermostat Sécurité Chaudière	Boiler Safety Thermostat	Sicherheitsthermostat Boiler	Termostato Sicurezza Caldaia
Tv =	Sonda Vapor	Sonde Vapeur	Steam Probe	Sonde Dampf	Sonda Vapore
VAC =	Bomba Vaciado	Pompe Vidange	Vacuum Pump	Ablaspumpe	Pompa scarico
VAcI =	Electro válvula Aclarado	Électrovanne Rinçage	Rinsing Solenoid Valve	Elektroventil Klarspülen	Elettrovalvola Risciacquo
VC =	Ventilador Soplante	Ventilateur Soufflant	Blowing Fan	Ventilator Gebläse	Ventilatore Soffiante
VCN =	Electro válvula Condensación	Électrovanne Condensation	Condensation Solenoid Valve	Elektroventil Kondensierung	Elettrovalvola Condensazione
VDV =	Electro válvula Llenado Caldera	Électrovanne Remplissage Chaudière	Chamber Filling Solenoid Valve	Elektroventil Füllung Boiler	Elettrovalvola di Riempimento Caldaia
VE =	Ventilador Cuadro Eléctrico	Ventilateur Tableau Électrique	Fan Switchboard	Ventilator Elektrotafel	Ventilatore Quadro Elettrico
VHM =	Electro válvula Humidificador	Électrovanne Humidificateur	Humidifier Solenoid Valve	Elektroventil BefeuchtungsVorrichtung	Elettrovalvola Umidificatore
VLav =	Electro válvula Lavado	Électrovanne Lavage	Washing Solenoid Valve	Elektroventil Waschen	Elettrovalvola Lavaggio
Wv =	Variador Velocidad	Variateur Vitesse	Speed Variator	Geschwindigkeitsregler	Variatore di Velocità
COLOR	COLORES	COULEURS	COLOUR	FARBEN	COLORE
Va =	Azul	Bleu	Blue	Blau	Blu
am =	Amarillo	Jaune	Yellow	Gelb	Giallo
am/ve =	Amarillo/verde	Jaune / vert	Yellow / green	Gelb/grün	Giallo/verde
b =	Blanco	Blanc	White	Weiß	Bianco
g =	Gris	Gris	Grey	Grau	Grigio
m =	Marrón	Marron	Brown	Braun	Marrone
n =	Negro	Noir	Black	Schwarz	Nero
na =	Naranja	Orange	Orange	Orange	Arancio
r =	Rojo	Rouge	Red	Rot	Rosso
rs =	Rosa	Rose	Pink	Rosa	Roseo
ve =	Verde	Vert	Green	Grün	Verde
vi =	Violeta	Violet	Purple	Violett	Viola