

**Lavavajillas de apertura frontal  
Lave-vaisselle à ouverture frontale  
Front loading dishwasher  
Geschirrspülmaschinen mit frontbeladung  
Lavastoviglie ad apertura frontale  
Lava-louças de apertura frontal**

**Modelos:**

**FI-30  
FI-30 B  
FI-30 UK  
FI-30 A.R  
FI-30 A.R+DD  
FI-30 B-BTUK**

***Junio 2007 June***

*Revisado Agosto 2013 August Revised*



---

F A G O R I N D U S T R I A L

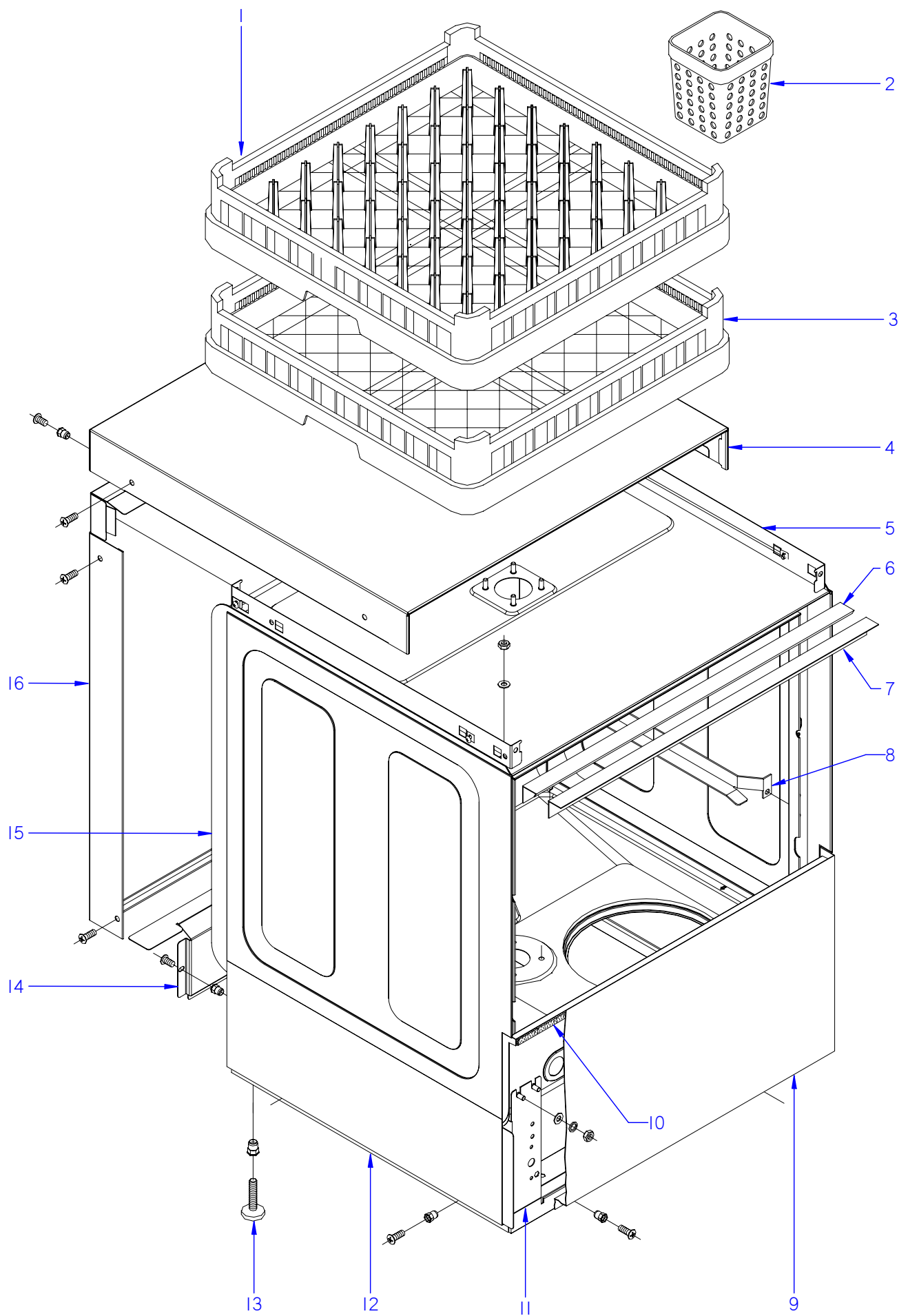

ITEM MARCADO EN COLOR = REPUESTO RECOMENDADO  
 COLOURED ITEM = RECOMMENDED SPARE PART

N plano	Firma	Fecha	Aparato	MUEBLE	Lamina	Fagor Industrial S.Coop. <b>FAGOR</b>
C-1818	<i>[Signature]</i>	2007-06	LAVAVAJILLAS FI-30		1	Oñate

MOD.		LAVAVAJILLAS DE APERTURA FRONTAL		ZONA	MUEBLE					PLANO	C-1818
ITEM	CODIGO	DENOMINACION	TEXTO	FI-30	FI-30 B	FI-30 UK	FI-30 A.R	FI-30 A.R+DD	FI-30 B-BTUK		NOTAS
1	Z655302000	CESTILLO PLATOS CP-16-18	PLATE BASKET CP-16-18	1	1	1	1	1	1		
2	Z655314000	CESTILLO CUBIERTOS	CUTLERY BASKET	4	4	1	1	1	1		
3	Z655301000	CESTILLO BASE CT-10	BASE BASKET CT-10	1	1	1	1	1	1		
	Z209121000	TOPE 50x50x80	BUFFER 50x50x80	2	2	2	2	2	2		
4	Z202906000	TAPA T-CO.	COVER T-CO.	1	1	1	1	1	1		
	Q221342000	REMACHE EXAGONAL M5	HEXAGONAL RIVET M5	2	2	2	2	2	2		
	Q152004000	TORNIL, APLASTADO M5x13 A304	FLAT HEADED BOLT M5x13 A304	2	2	2	2	2	2		
	Q152004000	TORNIL, APLASTADO M5x13 A304	FLAT HEADED BOLT M5x13 A304	4	4	4	4	4	4		
	Q221012000	TUERCA RAPIDA M,5	RAPID NUT M,5	4	4	4	4	4	4		
	3713500000	PERFIL CUBREARISTAS PLASTICO	PLASTIC EDGE COVER PROFILE	1	1	1	1	1	1		
5	Z200329000	ESCUADRA AMARRE TAPA AF	COVER FASTENING BRACKET A	2	2	2	2	2	2		ELIMINADO 29.01.10
5	Z200346000	ESCUADRA AMARRE TAPA AF	COVER FASTENING BRACKET A	2	2	2	2	2	2		INTRODUCIDO 29.01.10
	Q162040000	TUERCA EXAGONAL M6	WASHER A6	4	4	4	4	4	4		
	Q232040000	ARANDELA A6	HEXAGONAL BOLT M12x20	4	4	4	4	4	4		
	Q012073000	TORNIL. EXAGONAL M12x20 A.304	HEXAGONAL BOLTm12x20 A.304	1	1	1	1	1	1		
	Q306024000	JUNTA18X12.5X1.5	SEAL 18X12.5X1.5	1	1	1	1	1	1		
	Q162070000	TUERCA EXAGONAL M12	HEXAGONAL NUT M12	1	1	1	1	1	1		
6	Z200315000	PERFIL CAJA	BOX PROFILE	1	1	1	1	1	1		
7	Z200309000	ESCUADRA SUJECCION PERFIL	FASTENING BRACKET PROFILE	1	1	1	1	1	1		
8	Z200305000	GUIA CESTILLO DERECHO	RIGHT BASKET GUIDE	1	1	1	1	1	1		ELIMINADO 01.12.10
8	Z200347000	GUIA CESTILLO DERECHO	RIGHT BASKET GUIDE	1	1	1	1	1	1		INTRODUCIDO 01.12.10
S/Nº	Z200306000	GUIA CESTILLO IZQUIERDO	LEFT BASKET GUIDE	1	1	1	1	1	1		ELIMINADO 01.12.10
S/Nº	Z200348000	GUIA CESTILLO IZQUIERDO	LEFT BASKET GUIDE	1	1	1	1	1	1		INTRODUCIDO 01.12.10
	Q162040000	TUERCA EXAGONAL M6	WASHER A6	4	4	4	4	4	4		
	Q232040000	ARANDELA A6	HEXAGONAL NUT M6	4	4	4	4	4	4		
	Q012073000	TORNIL. EXAGONAL M12x20 A.304	HEXAGONAL BOLTm12x20 A.304	2	2	2	2	2	2		
9	Z202913000	PANEL FRONTAL SIN PUERTA	FRONT PANEL WITHOUT DOOR	1	-	1	1	1	-		
9	Z228812000	PANEL FRONTAL B SIN PUERTA	FRONT PANEL B WITHOUT DOOR	-	1	-	-	-	1		
	Q152004000	TORNIL, APLASTADO M5x13 A304	FLAT HEADED BOLT M5x13 A304	2	2	2	2	2	2		
10	Z200313000	PERFIL GOMA ESPONJOSA	FOAM RUBBER PROFILE	1	1	1	1	1	1		



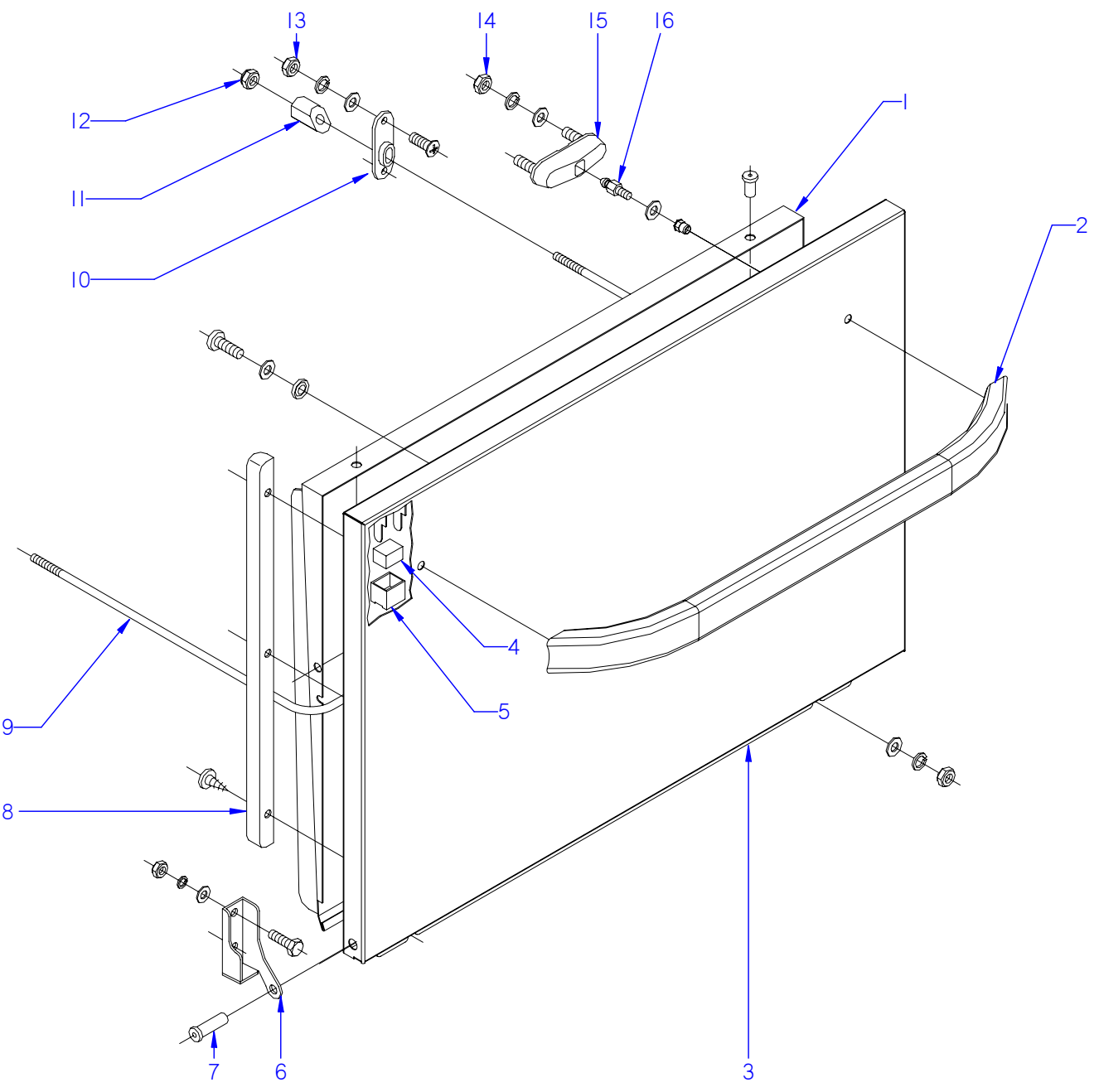

ITEM MARCADO EN COLOR = REPUESTO RECOMENDADO  
 COLOURED ITEM = RECOMMENDED SPARE PART

N plano <b>C-1819</b>	Firma <i>[Signature]</i>	Fecha <b>2007-06</b>	Aparato <b>LAVAVAJILLAS FI-30</b>	Lamina <b>2</b>	Fagor Industrial S. Coop. Omate
			PUERTA	<b>FAGOR</b>	

MOD.		LAVAVAJILLAS DE APERTURA FRONTAL		ZONA	PUERTA						PLANO	C-1819
ITEM	CODIGO	DENOMINACION	TEXTO	FI-30	FI-30 B	FI-30 UK	FI-30 A.R	FI-30 A.R+DD	FI-30 B-BTUK		NOTAS	
	<b>1200005030</b>	<b>KIT PUERTA LAVAJILLAS FI 30</b>	<b>DOOR KIT FI 30 DISHWASHER</b>	1	1	1	1	1	1			
1	Z200545000	CONTRAPUERTA SOLDADA	WELDED COUNTERDOOR	1	1	1	1	1	1		ELIMINADO 13.06.08	
1	Z200556000	CONTRAPUERTA SOLDADA	WELDED COUNTERDOOR	1	1	1	1	1	1		INTRODUCIDO 13.06.08	
	Q412000000	REMACHE TUBULAR 4 x 8	TUBULAR RIVET 4 x 8	4	4	4	4	4	4			
2	Z200551000	ASA PUERTA	DOOR HANDLE	1	1	1	1	1	1			
3	Z218005000	PUERTA SOLDADA	WELDED DOOR	1	1	1	1	1	1			
4	Z200506000	IMAN	MAGNET	1	1	1	1	1	1			
5	Z200507000	PROTECTOR IMAN	MAGNET PROTECTOR	1	1	1	1	1	1			
6	Z400514000	BISAGRA IZQUIERDA T-C.	LEFT HINGE T-C.	1	1	1	1	1	1			
	Q012042000	TORNIL. EXAGONAL M6X15 A.304	HEXAGONAL BOLT M6X15 A.304	2	2	2	2	2	2			
	Q232040000	ARANDELA A6	WASHER A6	2	2	2	2	2	2			
	Q262040000	ARANDELA GROW. A6 A.304	WASHER GROW. A6 A.304	2	2	2	2	2	2			
	Q162040000	TUERCA EXAGONAL M6	HEXAGONAL NUT M6	1	1	1	1	1	1			
S/Nº	Z400515000	BISAGRA DERECHA T-C.	RIGHT HINGE T-C.	1	1	1	1	1	1			
	Q012042000	TORNIL. EXAGONAL M6X15 A.304	HEXAGONAL BOLT M6X15 A.304	2	2	2	2	2	2			
	Q232040000	ARANDELA A6	WASHER A6	2	2	2	2	2	2			
	Q262040000	ARANDELA GROW. A6 A.304	WASHER GROW. A6 A.304	2	2	2	2	2	2			
	Q162040000	TUERCA EXAGONAL M6	HEXAGONAL NUT M6	1	1	1	1	1	1			
7	Z400516000	EJE PUERTA	DOOR SHAFT	2	2	2	2	2	2			
8	Z200524000	MARCO PUERTA	DOOR FRAME	2	2	2	2	2	2			
	Q032041000	TORNILLO ALOMADO M6X10	CURVED SCREW M6x10	2	2	2	2	2	2			
	Q308002000	ARANDELA DUBO A6 NYLON	WASHER DUBO A6 NYLON	2	2	2	2	2	2			
9	Z200521000	VARILLA TENSOR	TENSIONING ROD	1	1	1	1	1	1		ELIMINADO 13.06.08	
9	Z200555000	VARILLA TENSOR	TENSIONING ROD	1	1	1	1	1	1		INTRODUCIDO 13.06.08	
10	Z200310000	SOPORTE TENSOR	TENSOR SUPPORT	2	2	2	2	2	2			
11	Z200522000	TENSOR PUERTA	DOOR TENSOR	2	2	2	2	2	2			
12	Q222012000	TUERCA AUTOB. M6	SELF-LOCK NUT M6	2	2	2	2	2	2			
13	Q162030000	TUERCA EXAGONAL M5	HEXAGONAL NUT M5	4	4	4	4	4	4			
	Q152004000	TORNIL, APLASTADO M5x13 A304	FLAT HEADED BOLT M5x13 A304	4	4	4	4	4	4			
	Q232030000	ARANDELA A5	WASHER A5	4	4	4	4	4	4			
	Q262030000	ARANDELA GROW. A5 A.304	WASHER GROW. A5 A.304	4	4	4	4	4	4			



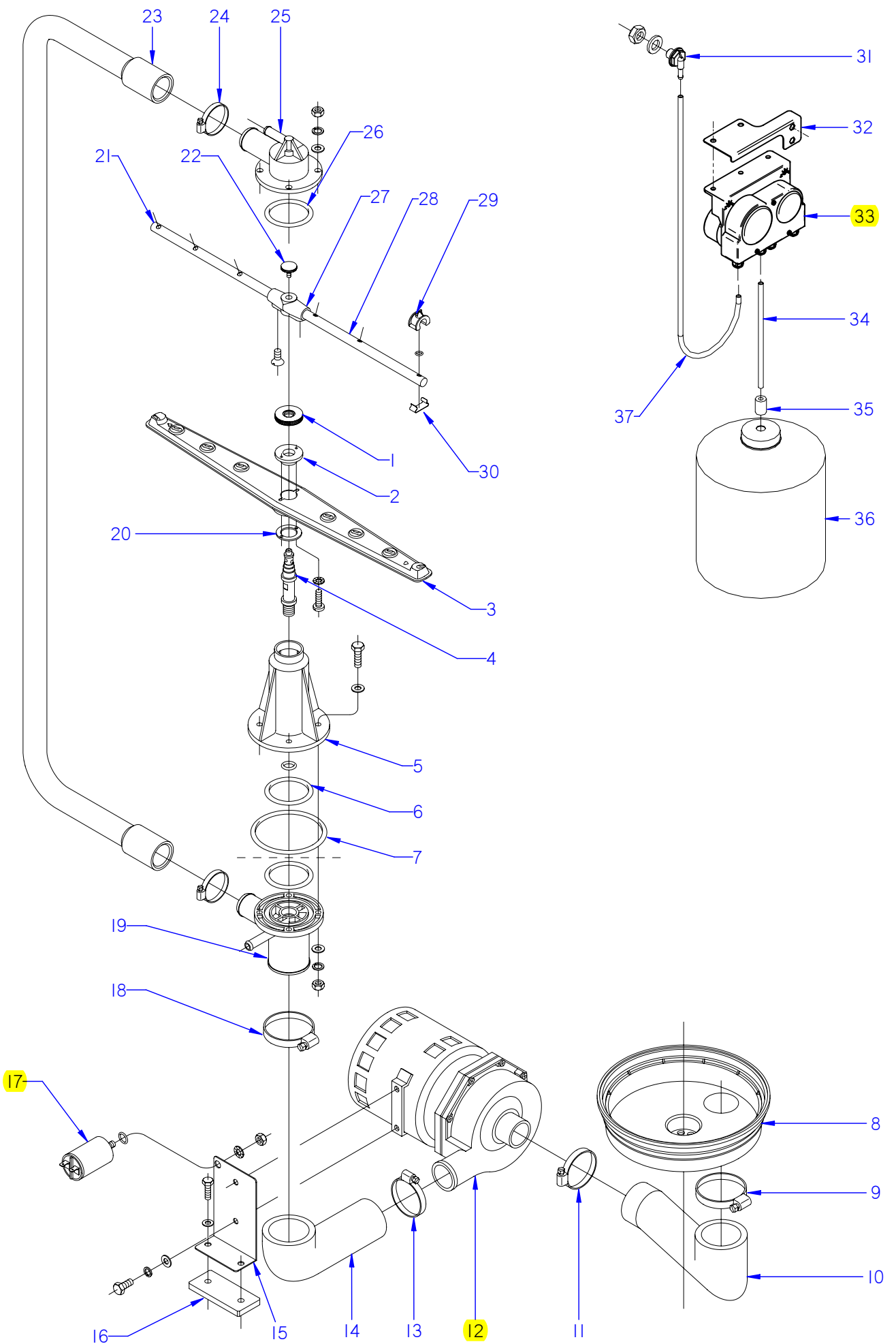

ITEM MARCADO EN COLOR = REPUESTO RECOMENDADO  
 COLOURED ITEM = RECOMMENDED SPARE PART

N plano	Firma	Fecha	Aparato	PARTE FUNCIONAL DE LAVADO	Lamina	Fagor Industrial S.Coop. <b>FAGOR</b>
C-1820	<i>[Signature]</i>	2007-06	LAVAVAJILLAS FI-30		3	Oñate

MOD.		LAVAVAJILLAS DE APERTURA FRONTAL		ZONA	PARTE FUNCIONAL LAVADO						PLANO	C-1820
ITEM	CODIGO	DENOMINACION	TEXTO	FI-30	FI-30 B	FI-30 UK	FI-30 A.R	FI-30 A.R+DD	FI-30 B-BTUK		NOTAS	
1	Z200705000	TUERCA ESPECIAL M.14X1	SPECIAL NUT M.14X1	2	2	2	2	2	2			
2	Z650704000	ENGANCHE DISTRIBUIDOR	DISTRIBUTOR CATCH	2	2	2	2	2	2		ELIMINADO 11.02.2013	
2	12045103	ENGANCHE DISTRIBUIDOR	DISTRIBUTOR CATCH	2	2	2	2	2	2		INTRODUCIDO 11.02.2013	
3	Z650716000	DISTRIBUIDOR MONTADO	DISTRIBUTOR MOUNTED	2	2	2	2	2	2			
4	Z200704000	EJE CENTRAL	CENTRAL SHAFT	2	2	2	2	2	2			
5	Z200701000	SOPORTE DISTRIBUID. INFERIOR	LOWER DISTRIBUTOR SUPPORT	1	1	1	1	1	1			
	Q307050000	JUNTA TOR.13.94X19.18X2.6	O-RING 13.94X19.18X2.6	1	1	1	1	1	1			
	Q012046000	TORNIL. EXAGONAL M6X40 A.304	HEXAGONAL BOLT M6X40 A.304	4	4	4	4	4	4			
	Q306050000	ARANDELA Ø6X12X1.5	WASHER Ø6X12X1.5	4	4	4	4	4	4			
6	Q307052000	JUNTA TOR.50.17X60.83X5.3	O-RING 50.17X60.83X5.3	2	2	2	2	2	2			
7	Q307049000	JUNTA TOR.85.09X95.75X5.3	O-RING 85.09X95.75X5.3	1	1	1	1	1	1			
8	Z200906000	CUBETA	TRAY	1	1	1	1	1	1			
9	Q881324000	ABRAZADERA 50-70L	CLAMP 50-70L	1	1	1	1	1	1			
10	Z200904000	CODO ASPIRACION 1003018	EXTRACTOR ELBOW 1003018	1	1	1	1	1	1			
11	Q881307000	ABRAZADERA 40-60	CLAMP 40-60	1	1	1	1	1	1			
12	Z201011000	BOMBA DE LAVADO	WASH PUMP	1	1	1	1	1	1			
	Z201082000	TURBINA PARA 50 HZ.88 MM	TURBINE 50 HZ.88 MM	1	1	1	1	1	1			
	Z201081000	CONJUNTO JUNTA Y RETEN	JOINT BOARD AND SEAL	1	1	1	1	1	1			
12	Z203511000	BOMBA DE LAVADO 60 HZ.	WASH PUMP 60 Hz.	1	1	1	1	1	1			
	Z201083000	TURBINA 60 HZ.78 MM	TURBINE 60 HZ.78 MM	1	1	1	1	1	1			
	Z201081000	CONJUNTO JUNTA Y RETEN	JOINT BOARD AND SEAL	1	1	1	1	1	1			
	Z203601000	RESISTENCIA TANQUE	TANK RESISTOR	1	1	1	1	1	1			
	R223005000	RESISTENCIA TANQUE	TANK RESISTOR						1			
13	Q881307000	ABRAZADERA 40-60	CLAMP 40-60	1	1	1	1	1	1			
14	Z200905000	CODO IMPULSION 1003017	IMPULSE ELBOW 1003017	1	1	1	1	1	1			
15	Z201002000	SOPORTE MOTOBO.F-3-4-5-6	MOTORPUMP SUPPORT F-3-4-5-	1	1	1	1	1	1			
16	Z201003000	BASE BOMBA LAVADO 1003016	WASH PUMP BASE 1003016	1	1	1	1	1	1			
	Q012033000	TORNIL. EXAGONAL M5X20 A.304	HEXAGONAL BOLT M5X20 A.304	2	2	2	2	2	2			
	Q232030000	ARANDELA A5	WASHER A5	2	2	2	2	2	2			
17	V321300000	CONDENSADOR 10 M.F.	CONDENSER 10 M.F.	1	1	1	1	1	1			
	Q307048000	JUNTA TORICA 9.12X16.18X3.53	O-RING 9.12x16.18x3.53	1	1	1	1	1	1			

MOD.		LAVAVAJILLAS DE APERTURA FRONTAL		ZONA	PARTE FUNCIONAL LAVADO					PLANO	C-1820
ITEM	CODIGO	DENOMINACION	TEXTO	FI-30	FI-30 B	FI-30 UK	FI-30 A.R	FI-30 A.R+DD	FI-30 B-BTUK		NOTAS
18	Q881324000	ABRAZADERA 50-70L	CLAMP 50-70L	1	1	1	1	1	1		
19	Z200703000	PASAMUROS	BUSHING	1	1	1	1	1	1		
	Q232040000	ARANDELA A6	WASHER A6	4	4	4	4	4	4		
	Q262040000	ARANDELA GROW. A6 A.304	WASHER GROW. A6 A.304	4	4	4	4	4	4		
	Q162040000	TUERCA EXAGONAL M6	HEXAGONAL NUT M6	4	4	4	4	4	4		
20	Z650711000	AMARRE ENGANCHE DISTRIBUID.	DISTRIBUTOR HOOK FASTENING	2	2	2	2	2	2		
	Q152015000	TORNILLO ALOMADO M3X6	CURVED SCREW M3X6	4	4	4	4	4	4		
	Q242010000	ARANDELA ABANICO A.3 A304	FAN WASHER A3 A304	4	4	4	4	4	4		
21	Z208712000	RAMA DE ACLARADO IZQUIERDA	LEFT RINSE BRANCH	2	2	2	2	2	2		
22	Q152016000	TORNILLO ESPECIAL M.5X0.8	SPECIAL BOLT M.5X0.8	2	2	2	2	2	2		
23	Z200706000	ARBOL DE LAVADO	WASH CAM	1	1	1	1	1	1		
24	Q881305000	ABRAZADERA 25-40	CLAMP 25-40	2	2	2	2	2	2		
25	Z200707000	SOPORTE DISTRIBUIDOR SUPER.	UPPER DISTRIBUTION SUPPORT	1	1	1	1	1	1		
	Q232040000	ARANDELA A6	WASHER A6	4	4	4	4	4	4		
	Q262040000	ARANDELA GROW. A6 A.304	WASHER GROW. A6 A.304	4	4	4	4	4	4		
	Q162040000	TUERCA EXAGONAL M6	HEXAGONAL NUT M6	4	4	4	4	4	4		
26	Q307052000	JUNTA TOR.50.17X60.83X5.3	O-RING 50.17X60.83X5.3	1	1	1	1	1	1		
27	Z201903000	SOPORTE RAMAS ACLARADO	RINSE BRANCH SUPPORT	2	2	2	2	2	2		
	Q042021000	TORN. AVELLANADO M4X10 A.304	HEXAGONAL COUNTERSUNK M4	4	4	4	4	4	4		
28	Z208713000	RAMA DE ACLARADO DERECHA	RIGHT RINSE BRANCH	2	2	2	2	2	2		
29	Z201905000	TOBERA ACLARADO	RINSE NOZZLE	12	12	12	12	12	12		
	Q307036000	JUNTA TORICA 5.28X8.84X1.78	O-RING 5.28X8.84X1.78	12	12	12	12	12	12		
30	Z201906000	ENGANCHE TOBERA ACLARADO	RINSE NOZZLE HOOK	12	12	12	12	12	12		
31	Z230902000	PASAMUROS DETERGENTE	DETERGENT WALL BUSHING	-	-	1	-	1	1		ELIMINADO 17.07.09
31	Z230905000	PASAMUROS DETERGENTE	INOX DETERGENT WALL BUSHIN	-	-	1	-	1	1		ELIMINADO 30.11.10
31	Z208927000	PASAMUROS DETERGENTE INOX	DETERGENT WALL BUSHING	-	-	1	-	1	1		INTRODUCIDO 30.11.10
	Q306024000	JUNTA Ø18X12.5X1.5	SEAL Ø18X12.5X1.5	-	-	1	-	1	1		
	Q162070000	TUERCA EXAGONAL M12	HEXAGONAL NUT M12	-	-	1	-	1	1		



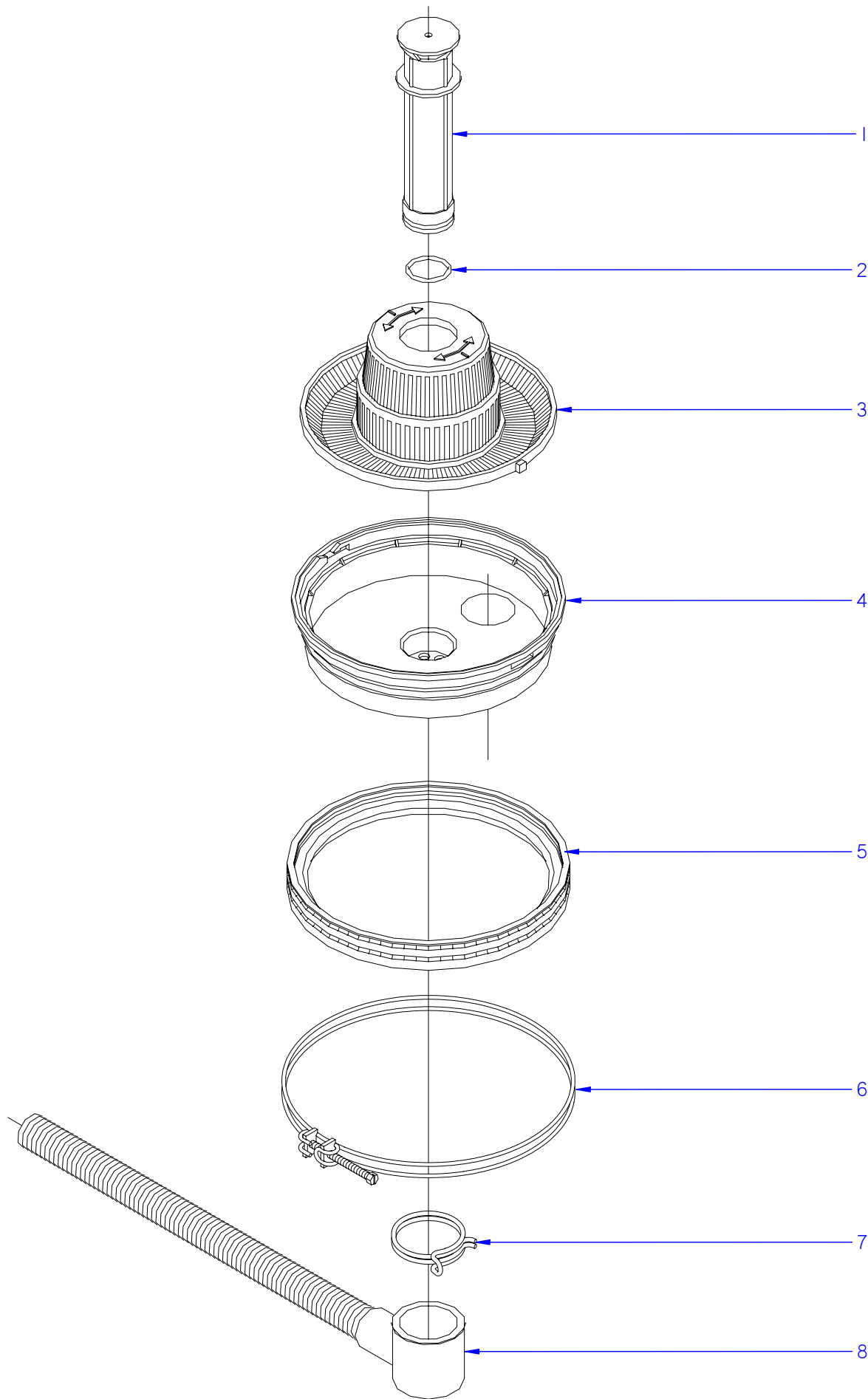

ITEM MARCADO EN COLOR = REPUESTO RECOMENDADO  
 COLOURED ITEM = RECOMMENDED SPARE PART

N plano	Firma	Fecha	Aparato	PARTE FUNCIONAL DESAGUE	Lamina	Fagor Industrial S.Coop. <b>FAGOR</b>
C-1821	<i>(Signature)</i>	2007-06	LAVAVAJIL. FI-30; UK; A.R; A.R+DD		4	Oñate



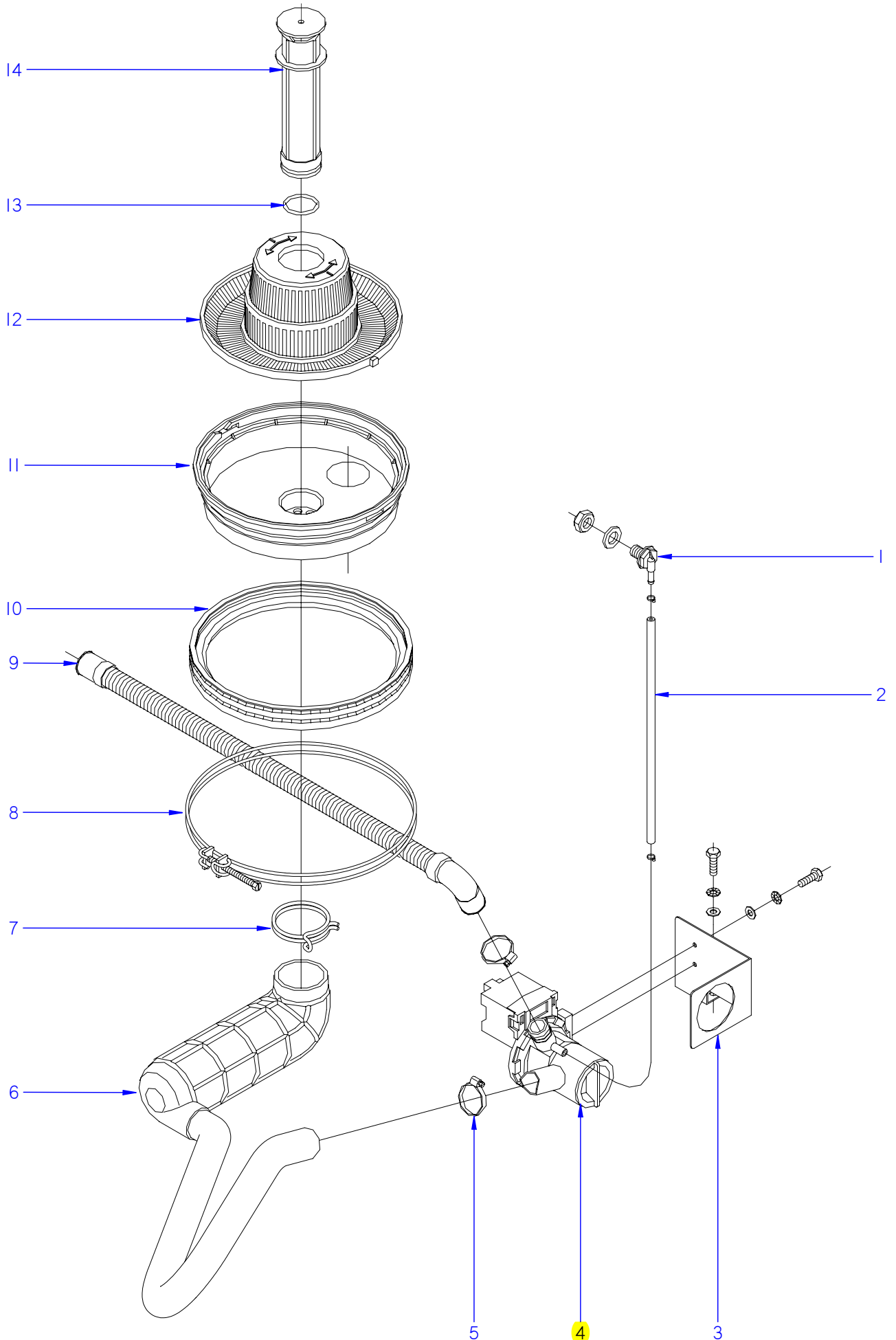

ITEM MARCADO EN COLOR = REPUESTO RECOMENDADO  
 COLOURED ITEM = RECOMMENDED SPARE PART

N plano	Firma	Fecha	Aparato	PARTE FUNCIONAL DESAGUE	Lamina	Fagor Industrial S.Coop. <b>FAGOR</b>
C-1822	<i>[Signature]</i>	2007-06	LAVAVAJILLAS FI-30 B; B-BTUK		5	Oñate

MOD.		LAVAVAJILLAS DE APERTURA FRONTAL		ZONA	PARTE FUNCIONAL DESAGÜE					PLANO	C-1822
ITEM	CODIGO	DENOMINACION	TEXTO	FI-30 B	FI-30 B-BTUK						NOTAS
1	Z230902000	PASAMUROS DETERGENTE	DETERGENT WALL BUSHING	1	1						ELIMINADO 17.07.09
1	Z230905000	PASAMUROS DETERGENTE INOX.	DETERGENT WALL BUSHING	1	1						INTRODUCIDO 17.07.09
	Q306024000	JUNTA Ø18X12.5X1.5	SEAL 18X12.5X1.5	1	1						ELIMINADO 12.04.2013
	12010191	JUNTA 14X24X3	SEAL 14X24X3	1	1						INTRODUCIDO 12.04.2013
	Q162070000	TUERCA EXAGONAL M12	HEXAGONAL NUT M12	1	1						
2	3702400000	TUBO GOMA NEGRO Ø 8*4	BLACK RUBBER PIPE Ø 8*4	1	1						
	P102154000	BRIDA ELASTICA TUBO	ELASTIC PIPE FLANGE	2	2						
3	Z220904000	SOPORTE BOMBA DESAGUE	DRAINAGE PUMP SUPPORT	1	1						
	Q012031000	TORNIL. EXAGONAL M5X10 A.304	HEX BOLT M5X10 A.304	4	4						
	Q242030000	ARANDELA ABANICO A5 A.304	FAN WASHER A5 A.304	4	4						
	Q232030000	ARANDELA A5	WASHER A5	4	4						
4	Z220901000	BOMBA DESAGUE 30W	DRAINAGE PUMP 30W	1	1						
4	Z223501000	BOMBA DESAGUE 30W 60HZ	DRAINAGE PUMP 30W 60HZ	1	1						
5	Q881305000	ABRAZADERA 25-40	CLAMP 25-40	2	2						
6	Z220902000	ACUMULADOR 1503019	ACCUMULATOR 1503019	1	1						
7	Q901308000	ABRAZAD. ELAST. 56-58.8	ELAST. CLAMP 56-58.8	1	1						
8	Z200908000	ABRAZADERA CUBETA COMPL.	COMPL. TRAY CLAMP	1	1						
9	Z220903000	MANGUERA DESAGUE	DRAINAGE HOSE	1	1						
10	Z200907000	JUNTA CUBETA	TRAY SEAL	1	1						
11	Z200906000	CUBETA	TRAY	1	1						
12	Z200922000	CONJUNTO FILTRO AF.	AF FILTER UNIT.	1	1						
13	Q307051000	JUNTA TOR.36.17X41.41X2.6	O-RING 36.17X41.41X2.6	1	1						
14	Z200909000	ALIVIADERO	OVERFLOW	1	1						ELIMINADO 24.06.2013
14	12049258	ALIVIADERO AF MODELO B	OVERFLOW AF MOD. B	1	1						INTRODUCIDO 24.06.2013

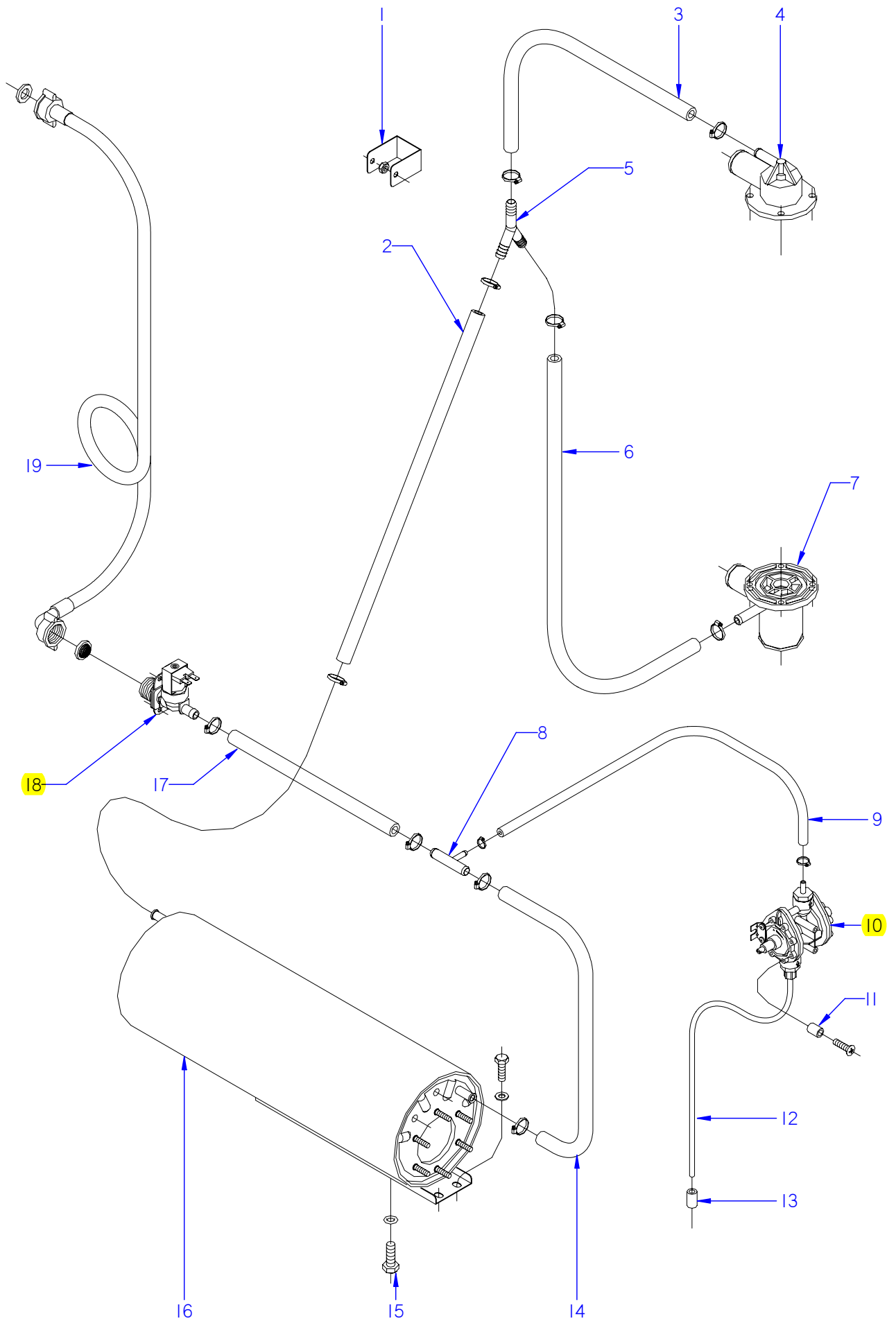

ITEM MARCADO EN COLOR = REPUESTO RECOMENDADO  
 COLOURED ITEM = RECOMMENDED SPARE PART

N plano	Firma	Fecha	Aparato	PARTE FUNCIONAL ACLARADO	Lamina	Fagor Industrial S.Coop. <b>FAGOR</b>
C-1823	<i>[Signature]</i>	2007-06	LAVAVAJILLAS FI-30; B; FI-30 UK		6	Oñate

MOD.		LAVAVAJILLAS DE APERTURA FRONTAL		ZONA	PARTE FUNCIONAL ACLARADO			PLANO	C-1823
ITEM	CODIGO	DENOMINACION	TEXTO	FI-30	FI-30 B	FI-30 UK			NOTAS
1	R722631000	FIJACION ALERON	AILERON FASTENING	1	1	1			ELIMINADO 01.01.09
	Q162040000	TUERCA EXAGONAL M6	HEXAGONAL NUT M6	1	1	1			
2	3676900000	TUBO GOMA NEGRA Ø 17*10	BLACK RUBBER PIPE 17*10	1	1	1			
	Q881302000	ABRAZADERA 12-20	CLAMP 12-20	2	2	2			
3	3676900000	TUBO GOMA NEGRA Ø 17*10	BLACK RUBBER PIPE 17*10	1	1	1			
	Q881302000	ABRAZADERA 12-20	CLAMP 12-20	2	2	2			
4	Z200707000	SOPORTE DISTRIB. SUPERIOR	UPPER DISTRIB. SUPPORT	1	1	1			
5	Z201106000	RACORD EN Y	Y-CONNECTION	1	1	1			
6	3676900000	TUBO GOMA NEGRA Ø 17*10	BLACK RUBBER PIPE 17*10	1	1	1			
	Q881302000	ABRAZADERA 12-20	CLAMP 12-20	2	2	2			
7	Z200703000	PASAMUROS	BUSHING	1	1	1			
8	Z601157000	TOMA PRESION	PRESSURE INTAKE	1	1	1			
9	3704000000	TUBO GOMA NEGRO D 10,5*5	BLACK RUBBER PIPE Ø 10.5*5	1	1	1			
	Q881308000	ABRAZADERA 8-14L	CLAMP 8-14L	2	2	2			
10	Z651123000	DOSIFICADOR TENSOACTIVO	SURFACE ACTIVE DISPENSER	1	1	1			ELIMINADO 03.04.09
10	Z211109000	DOSIFICADOR TENSOACTIVO N-6	SURFACE ACT. DISP. N-6	1	1	1			ELIMINADO 18.06.2012
10	12045206	DOSIFICADOR_ABRILLANTADOR_A	RINSE AID DISPENSER	1	1	1			INTRODUCIDO 18.06.2012
11	Z203007000	CASQUILLO	BUSHING	2	2	2			
12	Z448614000	CONDUCTO ASPIRACIÓN	EXTRACTOR PIPE			1			ELIMINADO 31.07.07
12	Z448618000	CONDUCTO ABRILLANTADOR	CROCKERY POLISHER PIPE	1	1	1			INTRODUCIDO 31.07.07
13	Z701152000	PESO FILTRO	FILTER WEIGHT	1	1	1			
14	3676900000	TUBO GOMA NEGRA Ø 17*10	BLACK RUBBER PIPE 17*10	1	1	1			
	Q881302000	ABRAZADERA 12-20	CLAMP 12-20	2	2	2			
15	Q012063000	TORNIL. EXAGONAL M10x20 A.304	HEXAGONAL BOLT M10X20 A.304	1	1	1			
	Q307048000	JUNTA TORICA Ø9.12X16.18X3.53	O-RING Ø9.12X16.18X3.53	1	1	1			
16	12022943	CALDERIN COMPLETO	COMPLETE DRUM	1	1	1			
17	3676900000	TUBO GOMA NEGRA Ø 17*10	BLACK RUBBER PIPE 17*10	1	1	1			
	Q881302000	ABRAZADERA 12-20	CLAMP 12-20	2	2	2			
18	Z701135000	ELECTR. SIMP.220V COD.255.208	SOLENOID VALVE SIMP.220V CO	1	1	1			
	Q152024000	TORN. AVELLANADO M4x8 A.304	HEXAGONAL COUNTERSUNK M4	2	2	2			
19	Z602121000	MANGUERA ENTRADA AGUA	WATER INTAKE HOSE	1	1	1			

N plano	Firma	Fecha	Aparato	Lamina	Fagor Industrial S. Coop.
C-1824	<i>(Firma)</i>	2007-06	LAVAVAJILLAS FI-30 B-BTUK	7	Omate
PARTE FUNCIONAL DE ACLARADO					

ITEM MARCADO EN COLOR = REPUESTO RECOMENDADO  
 COLOURED ITEM = RECOMMENDED SPARE PART

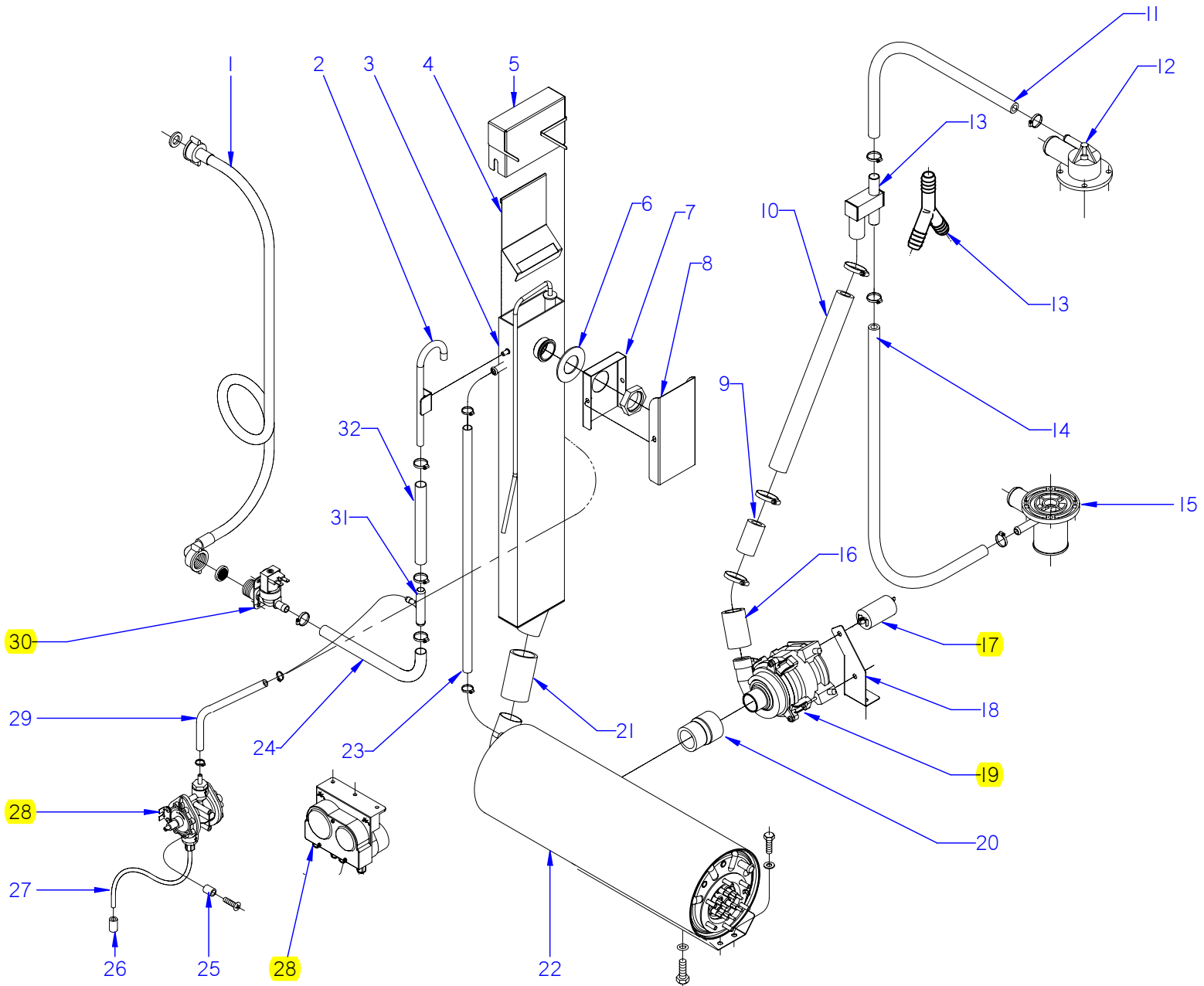

MOD.		LAVAVAJILLAS DE APERTURA FRONTAL		ZONA	PARTE FUNCIONAL ACLARADO					PLANO	C-1824
ITEM	CODIGO	DENOMINACION	TEXTO	FI-30 B-BTUK							NOTAS
1	Z602121000	MANGUERA ENTRADA AGUA	WATER INTAKE HOSE	1							
2	Z258903000	CAÑO COMPLETO	COMPLETE SPOUT	1							
	Q232040000	ARANDELA A6	WASHER A6	1							
	Q162040000	TUERCA EXAGONAL M6	HEXAGONAL NUT M6	1							
3	Z258906000	DEPÓSITO COMPLETO	COMPLETE TANK	1							
4	Z258953000	TAPA INTERIOR DEPOSITO	TANK INNER COVER	1							
5	Z258955000	CUBIERTA DEPÓSITO	TANK COVER	1							
	Q162040000	TUERCA EXAGONAL M6	HEXAGONAL NUT M6	1							
	Q232040000	ARANDELA A6	WASHER A6	1							
6	R675007000	JUNTA RETENCION VAPORES	STEAM RETAINER SEAL	1							
7	Z258938000	CUBIERTA PASAMUROS INTER.	INTER. BUSHING COVER	1							
	Q223014000	CONTRATUERCA 1 LATON	COUNTERNUT 1 BRASS	1							
8	Z258939000	CUBIERTA PASAMUROS EXTER.	EXTER. BUSHING COVER	1							
	Q222011000	REMACHE EXAGONAL M5 INOX.	HEXAGONAL RIVET M5 INOX	2							
	Q152004000	TORNIL, APLASTADO M5x13 A304	FLAT HEADED BOLT M5x13 A304	2							
9	Z257403000	MANGUITO IMPULSIÓN	IMPULSE HOSE	1							ELIMINADO 03.06.08
10	3722600000	TUBO EPDM 28.5 X 22 REFORZ.	PIPE EPDM 28.5 X 22 REINF.	1							ELIMINADO 01.12.08
10	Z258967000	MANGUERA ENJUAGUE BOMBA	RINSE PUMP HOSE	1							INTRODUCIDO 03.04.09
11	3676900000	TUBO GOMA NEGRA Ø 17*10	BLACK RUBBER PIPE 17*10	1							
	Q881302000	ABRAZADERA 12-20	CLAMP 12-20	2							
12	Z200707000	SOPORTE DISTRIB. SUPERIOR	UPPER DISTRIB. SUPPORT	1							
13	Z258934000	CONEXIÓN T COMPLETA	COMPLETE T CONNECTION	1							ELIMINADO 01.04.09
13	Z201106000	RACORD EN Y	Y-CONNECTION	1							INTRODUCIDO 15.04.09
14	3676900000	TUBO GOMA NEGRA Ø 17*10	BLACK RUBBER PIPE 17*10	1							
	Q881302000	ABRAZADERA 12-20	CLAMP 12-20	2							
15	Z200703000	PASAMUROS	BUSHING	1							
16	Z258933000	MANGUITO IMPULSIÓN	IMPULSE HOSE	1							ELIMINADO 01.12.08
	Q881306000	ABRAZADERA 32-50 L	CLAMP 32-50 L	4							
17	Z258927000	CONDENSADOR 3 µF	CONDENSER 3 µF	1							ELIMINADO 01.04.09
17	Z258969000	CONDENSADOR 5 µF	CONDENSER 5 µF	1							INTRODUCIDO 01.04.09

MOD.		LAVAVAJILLAS DE APERTURA FRONTAL		ZONA	PARTE FUNCIONAL ACLARADO					PLANO	C-1824
ITEM	CODIGO	DENOMINACION	TEXTO	FI-30 B-BTUK							NOTAS
18	Z258929000	SOPORTE M. BOMBA ACLARADO	M-PUMP SUPPORT RINSE	1							ELIMINADO 01.04.09
18	Z258968000	SOPORTE BOMBA HANNING	HANNING SUPPORT RINSE	1							INTRODUCIDO 01.04.09
	Q221342000	REMACHE EXAGONAL M5	HEXAGONAL RIVET M5	4							
	Q032035000	TORNILLO ALOMADO M5x30	CURVED SCREW M5X30	2							
	Q232030000	ARANDELA A5	WASHER A5	2							
	Q012031000	TORNILLO EXAGONAL M5x10	HEXAGONAL BOLT M5x10	2							
19	Z258926000	MOTOBOMBA	MOTORPUMP	1							ELIMINADO 01.04.09
19	Z258965000	BOMBA ACLARADO HANNING	RINSE PUMP	1							INTRODUCIDO 01.04.09
20	Z258931000	MANGUITO REDUCCIÓN	REDUCTION HOSE	1							
21	Z258925000	MANGUITO CONEXIÓN	CONNECTION HOSE	1							
	Q881306000	ABRAZADERA 32-50 L	CLAMP 32-50 L	2							
22	Z258916000	CALDERIN COMPLETO BBT	COMPLETE DRUM BBT	1							
23	3676900000	TUBO GOMA NEGRA Ø 17*10	BLACK RUBBER PIPE 17*10	1							
	Q881302000	ABRAZADERA 12-20	CLAMP 12-20	2							
24	3676900000	TUBO GOMA NEGRA Ø 17*10	BLACK RUBBER PIPE 17*10	1							
	Q881302000	ABRAZADERA 12-20	CLAMP 12-20	2							
25	Z203007000	CASQUILLO	BUSHING	2							ELIMINADO 01.02.08
	Q041324000	TORN. AVELLA. M4x25 H.ZINCADO	COUNTERSUNK NUT M4x25 H.ZI	2							ELIMINADO 01.02.08
26	Z701152000	PESO FILTRO	FILTER WEIGHT	1							ELIMINADO 01.02.08
27	Z448614000	CONDUCTO ASPIRACIÓN	EXTRACTOR PIPE	1							ELIMINADO 31.07.07
27	Z448618000	CONDUCTO ABRILLANTADOR	POLISH DUCT	1							INTRODUCIDO 06.09.10
28	Z651123000	DOSIFICADOR TENSOACTIVO	SURFACE ACTIVE DISPENSER	1							ELIMINADO 01.02.08
28	Z208915000	DOSIFIC. DGTE ABRILLANTADOR	DETERGENT DISP. POLISHER	1							INTRODUCIDO 01.02.08
29	3699200000	CONDUCTO DOSIFICADOR 6X4	CONDUIT 6X4	1							
	Q881308000	ABRAZADERA 8-14L	CLAMP 8-14L	2							
30	Z701135000	ELECTR. SIMP.220V COD.255.208	SOLENOID VALVE SIMP.220V CO	1							
	Z841107000	REGUL.ENTRADA 10L 254.067	REGULATOR 10L 254.067	1							INTRODUCIDO 27.02.12
31	Z601157000	TOMA PRESION	PRESSURE INTAKE	1							ELIMINADO 01.04.08
31	Z718949000	TE TOMA PRESION	PRESSURE INTAKE TE	1							ELIMINADO 06.09.10
32	3676900000	TUBO GOMA NEGRA Ø 17*10	BLACK RUBBER PIPE 17*10	1							ELIMINADO 06.09.10
	Q881302000	ABRAZADERA 12-20	CLAMP 12-20	2							ELIMINADO 06.09.10

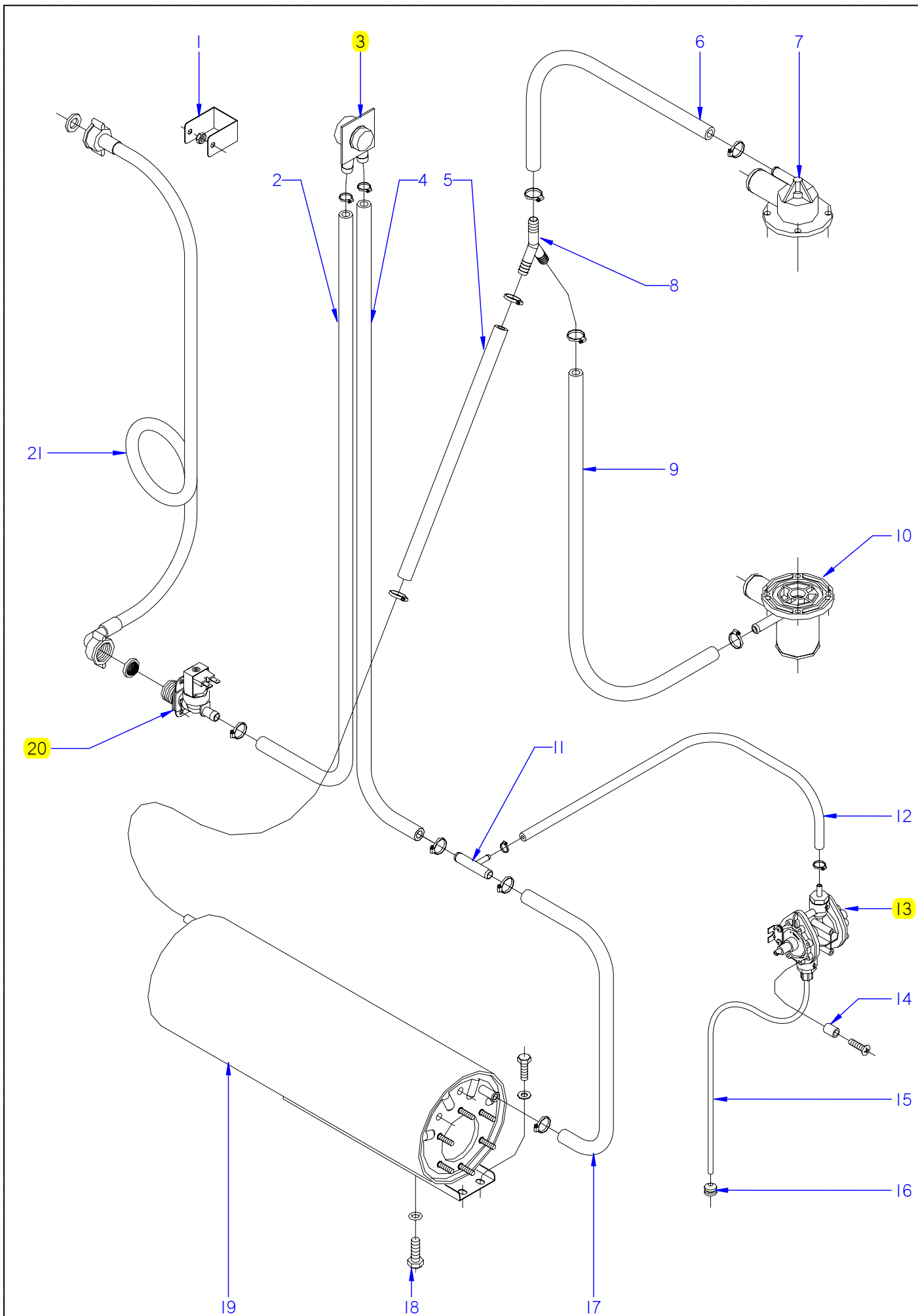

ITEM MARCADO EN COLOR = REPUESTO RECOMENDADO  
 COLOURED ITEM = RECOMMENDED SPARE PART

N plano	Firma	Fecha	Aparato	PARTE FUNCIONAL ACLARADO	Lamina	Fagor Industrial S.Coop. <b>FAGOR</b>
C-1825	<i>[Signature]</i>	2007-06	LAVAVAJILLAS FI-30 A.R; A.R+DD		8	Oñate

MOD.		LAVAVAJILLAS DE APERTURA FRONTAL		ZONA	PARTE FUNCIONAL ACLARADO				PLANO	C-1825
ITEM	CODIGO	DENOMINACION	TEXTO	FI-30 A.R.+DD	FI-30 A.R					NOTAS
1	R722631000	FIJACION ALERON	AILERON FASTENING	1	1					ELIMINADO 01.01.09
	Q162040000	TUERCA EXAGONAL M6	HEXAGONAL NUT M6	1	1					
2	3676900000	TUBO GOMA NEGRA Ø 17*10	BLACK RUBBER PIPE 17*10	1	1					
	Q881302000	ABRAZADERA 12-20	CLAMP 12-20	2	2					
3	Z231106000	VALVULA ANTIRRETORNO	NON-RETURN VALVE	1	1					
4	3676900000	TUBO GOMA NEGRA Ø 17*10	BLACK RUBBER PIPE 17*10	1	1					
	Q881302000	ABRAZADERA 12-20	CLAMP 12-20	2	2					
5	3676900000	TUBO GOMA NEGRA Ø 17*10	BLACK RUBBER PIPE 17*10	1	1					
	Q881302000	ABRAZADERA 12-20	CLAMP 12-20	2	2					
6	3676900000	TUBO GOMA NEGRA Ø 17*10	BLACK RUBBER PIPE 17*10	1	1					
	Q881302000	ABRAZADERA 12-20	CLAMP 12-20	2	2					
7	Z200707000	SOPORTE DISTRIB. SUPERIOR	UPPER DISTRIB. SUPPORT	1	1					
8	Z201106000	RACORD EN Y	Y-CONNECTION	1	1					
9	3676900000	TUBO GOMA NEGRA Ø 17*10	BLACK RUBBER PIPE 17*10	1	1					
	Q881302000	ABRAZADERA 12-20	CLAMP 12-20	2	2					
10	Z200703000	PASAMUROS	BUSHING	1	1					
11	Z601157000	TOMA PRESION	PRESSURE INTAKE	1	1					
12	3704000000	TUBO GOMA NEGRO D 10,5*5	BLACK RUBBER PIPE Ø 10.5*5	1	1					
	Q881308000	ABRAZADERA 8-14L	CLAMP 8-14L	2	2					
13	Z651123000	DOSIFICADOR TENSOACTIVO	SURFACE ACTIVE DISPENSER	1	1					ELIMINADO 03.04.09
13	Z211109000	DOSIFICADOR TENSOACTIVO N-6	SURFACE ACT. DISP. N-6	1	1					ELIMINADO 18.06.2012
13	12045206	DOSIFICADOR_ABRILLANTADOR_A	RINSE AID DISPENSER	1	1					INTRODUCIDO 18.06.2012
14	Z203007000	CASQUILLO	BUSHING	2	2					
	Q041324000	TORN. AVELLA. M4x25 H.ZINCADO	COUNTERSUNK NUT M4x25 H.ZIN	2	2					
15	Z448614000	CONDUCTO ASPIRACIÓN	EXTRACTOR PIPE	1	1					
16	Z701152000	PESO FILTRO	FILTER WEIGHT	1	1					
17	3676900000	TUBO GOMA NEGRA Ø 17*10	BLACK RUBBER PIPE 17*10	1	1					
	Q881302000	ABRAZADERA 12-20	CLAMP 12-20	2	2					
18	Q012063000	TORNIL. EXAGONAL M10x20 A.304	HEXAGONAL BOLT M10X20 A.304	1	1					
	Q307048000	JUNTA TORICA Ø9.12X16.18X3.53	O-RING Ø9.12X16.18X3.53	1	1					



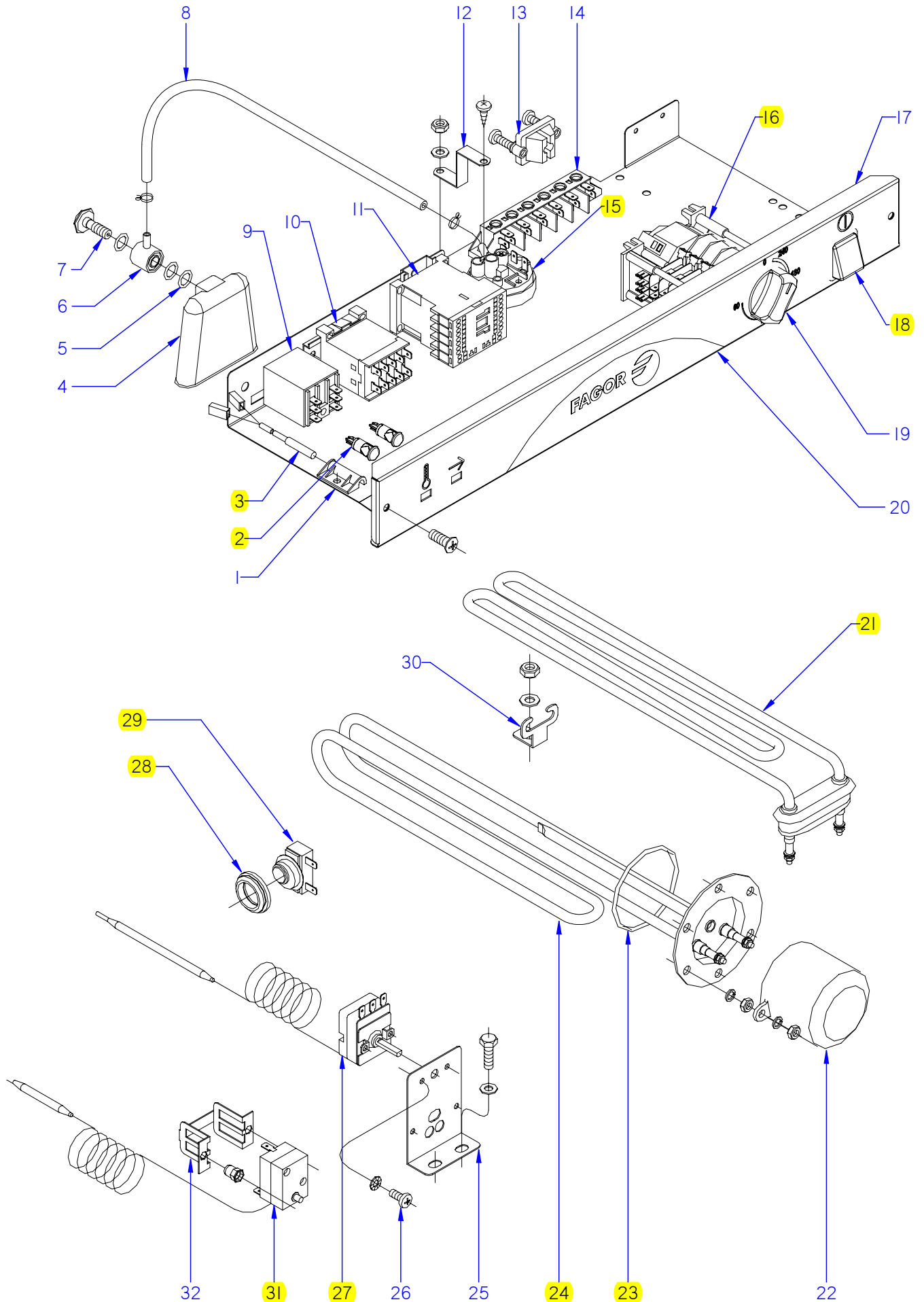

ITEM MARCADO EN COLOR = REPUESTO RECOMENDADO  
 COLOURED ITEM = RECOMMENDED SPARE PART

N plano	Firma	Fecha	Aparato	PARTE FUNCIONAL ELECTRICA	Lamina	Fagor Industrial S.Coop. <b>FAGOR</b>
C-1826	<i>(Signature)</i>	2007-06	LAVAVAJ. FI-30; UK; A.R; A.R+DD		9	Oñate

MOD.		LAVAVAJILLAS DE APERTURA FRONTAL		ZONA	PARTE FUNCIONAL ELECTRICA				PLANO	C-1826
ITEM	CODIGO	DENOMINACION	TEXTO	FI-30	FI-30 UK	FI-30 A.R	FI-30 A.R+DD			NOTAS
1	Z203010000	AMARRE INTERRUPT. MAGNETICO	MAGNETIC SWITCH FASTENER	1	1	1	1			
	Q152004000	TORNIL, APLASTADO M5x13 A304	FLAT HEADED BOLT M5x13 A304	1	1	1	1			
	Q232030000	ARANDELA A5	WASHER A5	1	1	1	1			
	Q162030000	TUERCA EXAGONAL M5	HEXAGONAL NUT M5	1	1	1	1			
2	R693056000	PILOTO AMBAR 41227000A4	AMBER PILOT 41227000A4	2	2	2	2			
3	Z203009000	INTERRUPTOR MAGNETICO	MAGNETIC SWITCH	1	1	1	1			
4	Z203011000	CAMARA PRESOSTATO	PRESSURE SWITCH	1	1	1	1			
5	Q307003000	JUNTA TORICA 16.01X10.77X2.62	O-RING 16.01X10.77X2.62	3	3	3	3			
6	Z203012000	EMPALME PRESOSTATO	PRESSURE SWITCH CONNEX	1	1	1	1			
7	Z203013000	TORNILLO PRESOSTATO	PRESSURE SWITCH BOLT	1	1	1	1			
8	370240000	TUBO GOMA NEGRO Ø 8*4	BLACK RUBBER PIPE Ø 8*4	1	1	1	1			
	P102154000	BRIDA ELASTICA TUBO	ELASTIC PIPE FLANGE	2	2	2	2			
9	Z203062000	RELE 230V. 16A 50-60 HZ	RELAY 230V. 16A 50-60 HZ	1	1	1	1			
10	Z213007000	CONTACTOR 230 V. 50-60 HZ	CONTACTOR 230 V. 50-60 HZ	1	1	1	1			ELIMINADO 01.11.08
10	Z203050000	CONTACTOR SIRIUS 3R 230V50-60	CONTACTOR SIRIUS 3R 230V50-	1	1	1	1			INTRODUCIDO 01.11.08
11	Z203050000	CONTACTOR SIRIUS 3R 230V50-60	CONTACTOR SIRIUS 3R 230V50-	1	1	1	1			
12	Z602923000	SOPORTE PRESOSTATO	PRESSURE SWITCH SUPPORT	1	1	1	1			
	Q082032000	TORNILLO ALOMADO BZ-3,5X9,5	CURVED SCREW BZ-3.5x9.5	1	1	1	1			
	Q152004000	TORNILLO APLASTADO M5x13	FLAT HEAD SCREW M5X13	1	1	1	1			
	Q232030000	ARANDELA A5	WASHER A5	1	1	1	1			
	Q162030000	TUERCA EXAGONAL M5	HEXAGONAL NUT M5	1	1	1	1			
13	Z203020000	RETENEDOR DE CABLE	CABLE HOLDER	1	1	1	1			
14	R253044000	REGLETA AUXILIAR FV-122	AUXILIARY TERMINAL STRIP FV-	1	1	1	1			
	Q152004000	TORNILLO APLASTADO M5x13	FLAT HEAD SCREW M5X13	2	2	2	2			
	Q232030000	ARANDELA A5	WASHER A5	2	2	2	2			
	Q162030000	TUERCA EXAGONAL M5	HEXAGONAL NUT M5	2	2	2	2			
15	Z203023000	PRESOSTATO SIMPLE PVS	SIMPLE PVS PRESSURE SWITCH	1	1	1	1			
16	Z203030000	PROGRAMADOR CICLO	CYCLE PROGRAMMER	1	1	1	1			
	Z203007000	CASQUILLO	BUSHING	2	2	2	2			
	Q041324000	TORN. AVELLA. M4x25 H.ZINCADO	COUNTERSUNK NUT M4x25 H.ZI	2	2	2	2			

MOD.		LAVAVAJILLAS DE APERTURA FRONTAL		ZONA	PARTE FUNCIONAL ELECTRICA				PLANO	C-1826
ITEM	CODIGO	DENOMINACION	TEXTO	FI-30	FI-30 UK	FI-30 A.R	FI-30 A.R+DD			NOTAS
17	Z202918000	FRENTE COMPLETO	COMPLETE FRONT	1	1	1	1			
	3713500000	PERFIL CUBREARISTAS PLASTICO	PLASTIC EDGE COVER PROFILE	1	1	1	1			
18	Z203071000	INTERRUPTOR NEGRO	BLACK SWITCH	1	1	1	1			
19	Z203069000	BOTON DE MANDO	CONTROL BUTTON	1	1	1	1			
20	Z202917000	EMBELLECEDOR ADHESIVO FI-30	ADHESIVE TRIM FI-30	1	1	1	1			
21	Z203601000	RESISTENCIA TANQUE	TANK RESISTOR	1		1	1			
21	R223005000	RESISTENCIA TANQUE	TANK RESISTOR		1					
22	Z651731000	CAPERUZA RESISTEN. CALDERIN	DRUM RESIST. CAP	1	1	1	1			ELIMINADO 10.04.09
22	Z101723000	CAPERUZA RESISTEN. CALDERIN	DRUM RESIST. CAP	1	1	1	1			INTRODUCIDO 10.04.09
	Q163140000	TUERCA EXAGONAL M6 LATON	HEXAGONAL NUT M6 BRASS	2	2	2	2			
23	Q307035000	JUNTA TORICA AN-36 282333	O-RING AN-36 282333	1	1	1	1			
24	Z201706000	RESISTENCIA CALDERIN	DRUM RESISTOR	1		1	1			
24	Z201708000	RESISTENCIA CALDERIN AF 2200W	DRUM RESISTORAF 2200W		1					
25	Z203047000	SOPORTE TERMOSTATOS	THERMOSTAT SUPPORT	1	1	1	1			
	Q012031000	TORNIL. EXAGONAL M5X10 A.304	HEXAGONAL BOLT M5X10 A.304	2	2	2	2			
	Q232030000	ARANDELA A5	WASHER A5	2	2	2	2			
26	Q152024000	TORNIL. AVELLANADO M4X8 A304	COUNTERSUNK BOLT M4X8 A304	2	2	2	2			
27	Z203014000	TERMOSTATO CALDERIN	WASH DRUM THERMOSTAT	1	1	1	1			ELIMINADO 01.11.2012
27	12040858	TERMOSTATO CALDERIN	WASH DRUM THERMOSTAT	1	1	1	1			INTRODUCIDO 01.11.2012
28	N503017000	SOPORTE TERMOSTATO 1001713	THERMOSTAT SUPPORT 1001713	1	1	1	1			
29	Z718405000	TERMOSTATO DOBLE	DOUBLE THERMOSTAT	1	1	1	1			
30	Z603602000	SOPORTE RESISTENCIA TANQUE	TANK RESISTOR SUPPORT	1	1	1	1			
	Q232040000	ARANDELA A6	WASHER A6	1	1	1	1			
	Q162040000	TUERCA EXAGONAL M6	HEXAGONAL NUT M6	1	1	1	1			
31	Z213014000	LIMITADOR TECASA P.	LIMITER TECASA P.	1	1	1	1			INTRODUCIDO 19.01.10
32	Z203060000	AMARRE LIMITADOR TECASA	LIMITER FASTENING TECASA	1	1	1	1			INTRODUCIDO 19.01.10

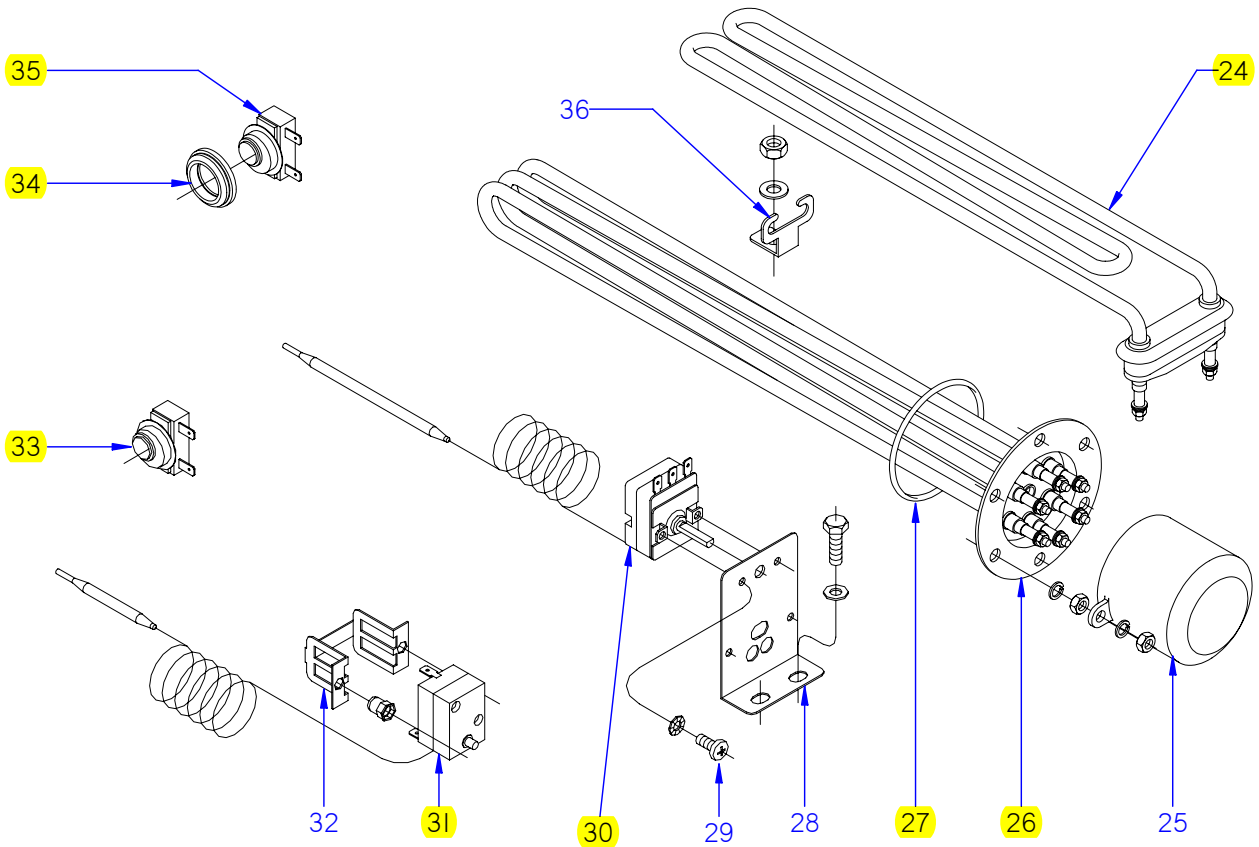
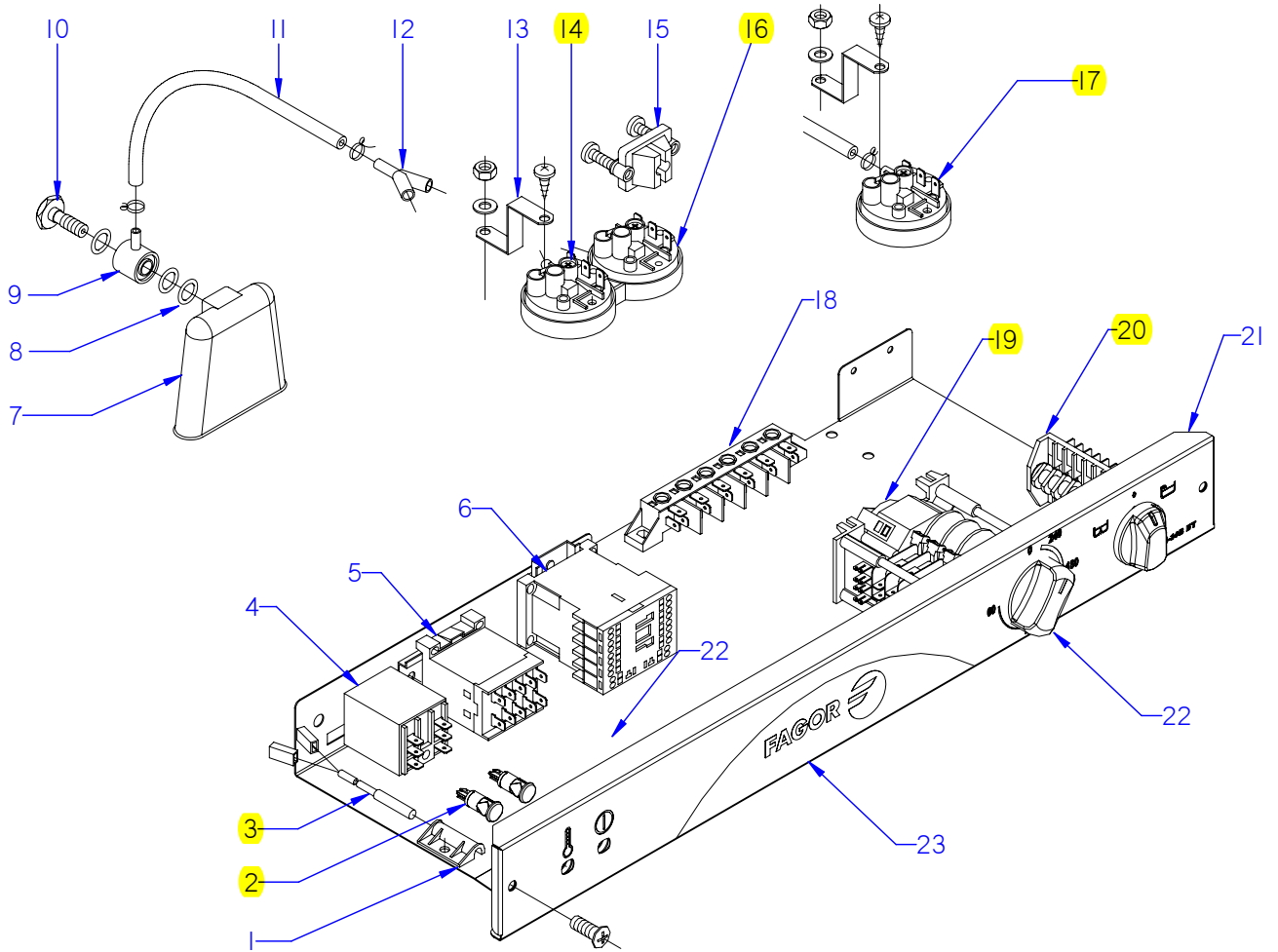

ITEM MARCADO EN COLOR = REPUESTO RECOMENDADO  
 COLOURED ITEM = RECOMMENDED SPARE PART

N plano	Firma	Fecha	Aparato	PARTE FUNCIONAL ELECTRICA	Lamina	Fagor Industrial S.Coop. <b>FAGOR</b>
C-1827	<i>[Signature]</i>	2007-06	LAVAVAJILLAS FI-30 B; B-BTUK		10	Oñate

MOD.		LAVAVAJILLAS DE APERTURA FRONTAL		ZONA	PARTE FUNCIONAL ELECTRICA					PLANO	C-1827
ITEM	CODIGO	DENOMINACION	TEXTO	FI-30 B	FI-30 B-BTUK						NOTAS
1	Z203010000	AMARRE INTERRUPT. MAGNETICO	MAGNETIC SWITCH FASTENER	1	1						
	Q152004000	TORNIL, APLASTADO M5x13 A304	FLAT HEADED BOLT M5x13 A304	1	1						
	Q232030000	ARANDELA A5	WASHER A5	1	1						
	Q162030000	TUERCA EXAGONAL M5	HEXAGONAL NUT M5	1	1						
2	R693056000	PILOTO AMBAR 41227000A4	AMBER PILOT 41227000A4	2	2						
3	Z203009000	INTERRUPTOR MAGNETICO	MAGNETIC SWITCH	1	1						
4	Z203062000	RELE 230V. 16A 50-60 HZ	RELAY 230V. 16A 50-60 HZ	1	1						
5	Z213007000	CONTACTOR 230 V. 50-60 HZ	CONTACTOR 230 V. 50-60 HZ	1	1						ELIMINADO 01.11.08
5	Z203050000	CONTACTOR SIRIUS 3R 230V50-60	CONTACTOR SIRIUS 3R 230V50-	1	1						INTRODUCIDO 01.11.08
6	Z203050000	CONTACTOR SIRIUS 3R 230V50-60	CONTACTOR SIRIUS 3R 230V50-	1	1						
7	Z203011000	CAMARA PRESOSTATO	PRESSURE SWITCH	1	1						
8	Q307003000	JUNTA TORICA 16.01X10.77X2.62	O-RING 16.01X10.77X2.62	3	3						
9	Z203012000	EMPALME PRESOSTATO	PRESSURE SWITCH CONNEX	1	1						
10	Z203013000	TORNILLO PRESOSTATO	PRESSURE SWITCH BOLT	1	1						
11	3702400000	TUBO GOMA NEGRO Ø 8*4	BLACK RUBBER PIPE Ø 8*4	1	1						
	P102154000	BRIDA ELASTICA TUBO	ELASTIC PIPE FLANGE	2	2						
12	Z103077000	RACORD EN Y	Y-CONNECTION	1	1						
13	Z602923000	SOPORTE PRESOSTATO	PRESSURE SWITCH SUPPORT	2	2						
	Q082032000	TORNILLO ALOMADO BZ-3,5X9,5	CURVED SCREW BZ-3.5x9.5	2	2						
	Q152004000	TORNILLO APLASTADO M5x13	FLAT HEAD SCREW M5X13	2	2						
	Q232030000	ARANDELA A5	WASHER A5	2	2						
	Q162030000	TUERCA EXAGONAL M5	HEXAGONAL NUT M5	2	2						
14	Z203023000	PRESOSTATO SIMPLE PVS	SIMPLE PVS PRESSURE SWITCH	1	1						
15	Z203020000	RETENEDOR DE CABLE	CABLE HOLDER	1	1						
16	Z223005000	PRESOSTATO SIMPLE P.V.S.	SIMPLE P.V.S. PRESSURE SWITC	1	1						
17	Z213059000	TRIPLE PRESOSTATO 40-120-150	TRIPLE PRESSURE SWITCH 40-1		1						
18	R253044000	REGLETA AUXILIAR FV-122	AUXILIARY TERMINAL STRIP FV-	1	1						
	Q152004000	TORNILLO APLASTADO M5x13	FLAT HEAD SCREW M5X13	2	2						
	Q232030000	ARANDELA A5	WASHER A5	2	2						
	Q162030000	TUERCA EXAGONAL M5	HEXAGONAL NUT M5	2	2						

MOD.		LAVAVAJILLAS DE APERTURA FRONTAL		ZONA	PARTE FUNCIONAL ELECTRICA				PLANO	C-1827
ITEM	CODIGO	DENOMINACION	TEXTO	FI-30 B	FI-30 B-BTUK					NOTAS
19	Z203030000	PROGRAMADOR CICLO	CYCLE PROGRAMMER	1	1					
	Z203007000	CASQUILLO	BUSHING	2	2					
20	Z223001000	CONMUTADOR DE FUNCIONES	FUNCTIONS SWITCH	1	1					
21	Z202918000	FRENTE COMPLETO	COMPLETE FRONT	1	1					
	3713500000	PERFIL CUBREARISTAS PLASTICO	PLASTIC EDGE COVER PROFILE	1	1					
22	Z203069000	BOTON DE MANDO	CONTROL BUTTON	2	2					
23	Z202922000	EMBELLEC. ADHESIVO FI-30 B	TRIM ADHESIVE FI-30 B	1						
23	Z202919000	EMBELLEC. ADHESIVO FI-30 B-BT	TRIM ADHESIVE FI-30 B-BT		1					
24	Z203601000	RESISTENCIA TANQUE	TANK RESISTOR	1						
24	R223005000	RESISTENCIA TANQUE	TANK RESISTOR		1					
25	Z651731000	CAPERUZA RESISTEN. CALDERIN	DRUM RESIST. CAP	1	1					ELIMINADO 10.04.09
25	Z101723000	CAPERUZA RESISTEN. CALDERIN	DRUM RESIST. CAP	1	1					INTRODUCIDO 10.04.09
26	Z201706000	RESISTENCIA CALDERIN	DRUM RESISTOR	1						
26	Z201708000	RESISTENCIA CALDERIN AF 2200W	DRUM RESISTOR		1					
	Q221305000	TUERCA EX.AUTO M4 ZINCADA	EX.AUTO NUT M4 ZINC-COATED	2	2					
	Q163140000	TUERCA EXAGONAL M6 LATON	HEXAGONAL NUT M6 BRASS	6	6					
	Q262040000	ARANDELA GROW. A6 A.304	WASHER GROW. A6 A.304	6	6					
27	Q307035000	JUNTA TORICA AN-36 282333	O-RING 9.12x16.18x3.53	1	1					
28	Z203047000	SOPORTE TERMOSTATOS	THERMOSTAT SUPPORT	1	1					
	Q012031000	TORNIL. EXAGONAL M5X10 A.304	HEXAGONAL BOLT M5X10 A.304	2	2					
	Q232030000	ARANDELA A5	WASHER A5	2	2					
29	Q152024000	TORNIL. AVELLANADO M4X8 A304	COUNTERSUNK BOLT M4X8 A304	2	2					
30	Z203014000	TERMOSTATO CALDERIN	WASH DRUM THERMOSTAT	1	1					ELIMINADO 01.11.2012
30	12040858	TERMOSTATO CALDERIN	WASH DRUM THERMOSTAT	1	1					INTRODUCIDO 01.11.2012
31	Z213014000	LIMITADOR TECASA P.	LIMITER TECASA P.	1	1					
32	Z203060000	AMARRE LIMITADOR TECASA	LIMITER FASTENING TECASA	1	1					
33	Z718441000	TERMOSTATO DOBLE W	DOUBLE THERMOSTAT W	1	1					ELIMINADO 03.07.07
33	Z718405000	TERMOSTATO DOBLE	DOUBLE THERMOSTAT	1	1					INTRODUCIDO 03.07.07
34	N503017000	SOPORTE TERMOSTATO 1001713	THERMOSTAT SUPPORT 1001713	1	1					
35	Z718405000	TERMOSTATO DOBLE	DOUBLE THERMOSTAT	1	1					
36	Z603602000	SOPORTE RESISTENCIA TANQUE	TANK RESISTOR SUPPORT	1	1					

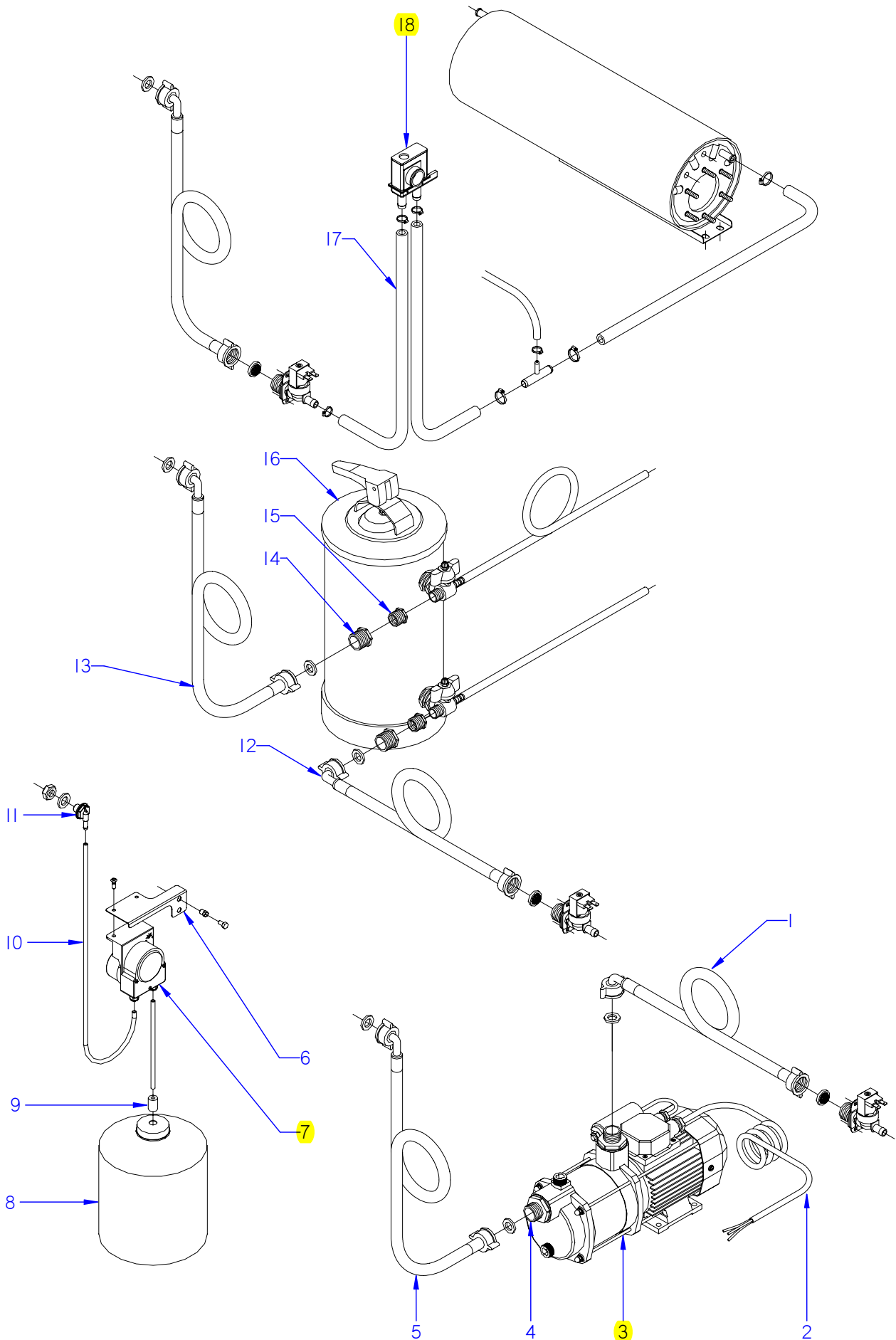

ITEM MARCADO EN COLOR = REPUESTO RECOMENDADO  
 COLOURED ITEM = RECOMMENDED SPARE PART

N plano	Firma	Fecha	Aparato	ACCESORIOS	Lamina	Fagor Industrial S.Coop. <b>FAGOR</b>
C-1828	<i>(Signature)</i>	2007-06	LAVAVAJ. FI-30; UK; A.R; A.R+DD		11	Oñate

MOD.		LAVAVAJILLAS DE APERTURA FRONTAL		ZONA	ACCESORIOS PARA LAVAVAJILLAS				PLANO	C-1828	
ITEM	CODIGO	DENOMINACION	TEXTO	FI-30	FI-30 UK	FI-30 A.R	FI-30 A.R+DD				NOTAS
	<b>1200000125</b>	<b>KIT BOMBA PRESION</b>	<b>PRESSURE PUMP KIT</b>								
1	-	MANGUERA DE MAQUINA	MACHINE HOSE	-	-	-	-				
2	Z209510000	CABLEADO BOMBA PRESION	PRESSURE PUMP WIRING	1	1	1	1				
3	Z209508000	BOMBA PRESION PRISMA 15	PRESSURE PUMP PRISMA 15	1	1	1	1				
4	Z209509000	MANGUITO	HOSE	2	2	2	2				
5	Z602121000	MANGUERA ENTRADA AGUA	WATER INTAKE HOSE	1	1	1	1				
	Q306037000	ARANDELA Ø42.5X32X1.5	WASHER Ø42.5X32X1.5	2	2	2	2				
	<b>1200000132</b>	<b>KIT DOSIFICADOR DETERGENTE</b>	<b>DETERGENT DISPENSER KIT</b>								
6	Z208434000	SOPORTE DOSIFICADOR W	DISPENSER SUPPORT W	1	1	1	1				
	Q411304000	REMACHE AVIBULB Ø4,8	AVIBULB RIVET Ø4.8	2	2	2	2				
	Q221342000	REMACHE EXAGONAL M5	HEXAGONAL RIVET M5	2	2	2	2				
	Q012031000	TORNIL.EXAGONAL M5X10 A.304	HEX BOLT M5X10 A.304	2	2	2	2				
	Q232030000	ARANDELA A5	WASHER A5	2	2	2	2				
	Q162030000	TUERCA EXAGONAL M5	HEXAGONAL NUT M5	2	2	2	2				
7	Z208903000	DOSIFIC. DGTE REGULABLE G300	DETERGENT DISP. ADJUST. G30	1	1	1	1				
8	-	GARRAFA DETERGENTE	DETERGENT CONTAINER	1	1	1	1				
9	Z701152000	PESO FILTRO	FILTER WEIGHT	1	1	1	1				
10	Z448614000	CONDUCTO ASPIRACIÓN	EXTRACTOR PIPE	1	1	1	1				
11	Z230902000	PASAMUROS DETERGENTE	DETERGENT WALL BUSHING	1	1	1	1				
	Q306024000	JUNTA Ø18X12.5X1.5	SEAL Ø18X12.5X1.5	1	1	1	1				
	Q162070000	TUERCA EXAGONAL M12	HEXAGONAL NUT M12	1	1	1	1				
S/Nº	Z208904000	CABLEADO DOSIFICADOR DTGTE	DETERGENT DISP. WIRING	1	1	1	1				







MOD.		LAVAVAJILLAS DE APERTURA FRONTAL		ZONA	PIEZAS ESPECIFICAS PARA AZKOYEN				PLANO	
ITEM	CODIGO	DENOMINACION	TEXTO	A-320	A-320B					NOTAS
	Z658602000	ASA PUERTA	DOOR HANDLE	1	1					
	Z200541000	PUERTA SOLDADA	WELDED DOOR	1	1					
	Z230902000	PASAMUROS DETERGENTE	DETERGENT WALL BUSHING	1	1					
	Z448614000	CONDUCTO ASPIRAC. AZKOYEN	AZKOYEN EXTRACTOR PIPE	1	1					
	Z701152000	PESO FILTRO	FILTER WEIGHT	1	1					
	Z208604000	EMBELLECEDOR ADHESIVO	TRIM ADHESIVE	1	1					
	Z208802000	EMBELLECEDOR ADHESIVO	TRIM ADHESIVE	1	1					
	Z218612000	ADHESIVO PANEL AZKOYEN	AZKOYEN PANEL ADHESIVE	1	1					
	Z228813000	ADHESIVO PANEL AZKOYEN	AZKOYEN PANEL ADHESIVE	1	1					
	Z202907000	FRENTE EXTRAIBLE FI-30	FI-30 DETACHABLE FRONT	1	1					
	Z208801000	FRENTE EXTRAIBLE A-320-B	A-320-B DETACHABLE FRONT	1	1					
	Z658813000	BOTON DE MANDO	CONTROL BUTTON	1	1					
	Z658607000	INDICADOR	INDICATOR	1	1					
	Z203033000	INTERRUPTOR GENERAL	SWITCH	1	1					
	R693055000	PILOTO VERDE 41227000C7	GREEN PILOT 41227000C7	1	1					
	Z200330000	CAJA SOLDADA AZKOYEN	AZKOYEN WELDED BOX	1	1					
	Z220904000	SOPORTE BOMBA DESAGUE	DRAINAGE PUMP SUPPORT	1	1					
	Z220901000	BOMBA DESAGUE 30W	DRAINAGE PUMP 30W	1	1					
	Z220902000	ACUMULADOR 1503019	ACCUMULATOR 1503019	1	1					
	Z220903000	MANGUERA DESAGÜE	DRAINAGE HOSE	1	1					
	Z228812000	PANEL FRONTAL B SIN PUERTA	FRONT PANEL B WITHOUT DOOR	1	1					
	Z223001000	CONMUTADOR DE FUNCIONES	FUNCTIONS SWITCH	1	1					
	Z223005000	PRESOSTATO SIMPLE P.V.S.	SIMPLE PVS PRESSURE SWITCH	1	1					
	Z103077000	RACORD EN Y	Y-CONNECTION	1	1					
	Z208809000	CABLE. BOMBA DESAGUE A 320 B	DRAINAGE PUMP WIRING	1	1					
	Z208810000	ESQUEMA TEORICO A 320 B	THEORET. DIAGRAM A 320 B	1	1					PLANO HC-17924
	Z208808000	ESQUEMA DE MONTAJE FI-30 B	ASSEMBLY PLAN FI-30 B	1	1					PLANO HC-17264
	Z448613000	CABLE DOSIFICADOR AZKOYEN	DISPENSER WIRING	1	1					
	Z208608000	LIBRO DE INSTRUCCIONES	INSTRUCTION LEAFLET	1	1					

















MOD.		LAVAVAJILLAS DE APERTURA FRONTAL		ZONA	PIEZAS ESPECIFICAS PARA AQUATEC SPECIFIC PARTS FOR AQUATEC				PLANO	
ITEM	CODIGO	DENOMINACION	TEXTO	AQUATEC RAPI						NOTAS
<b>PIEZAS A ELIMINAR EN FI-30 B-BTUK / PARTS TO CLEAR IN FI-30 B-BTUK</b>										
	Z200346000	ESCUADRA AMARRE TAPA AF	COVER FASTENING BRACKET A	2						
	Z200551000	ASA PUERTA	DOOR HANDLE	1						
	Z218005000	PUERTA SOLDADA	WELDED DOOR	1						
	Z202919000	EMBELLEC. ADHESIVO FI-30 B-BT	TRIM ADHESIVE FI-30 B-BT	1						
	Z202918000	FRENTE COMPLETO	COMPLETE FRONT	1						
	Z203069000	BOTON DE MANDO	CONTROL BUTTON	2						
	R693056000	PILOTO AMBAR 41227000A4	AMBER PILOT 41227000A4	1						
	Z206131000	FOLLETO DE INSTRUCCIONES	INSTRUCTION LEAFLET	1						
<b>PIEZAS A INTRODUCIR EN AQUATEC / PARTS TO MAKE AQUATEC</b>										
	Z208736000	ESCUADRA AMARRE TAPA ASPES	COVER FASTENING BRACKET A	2						
	Z208740000	PUERTA COMPLETA	DOOR	1						
	Z204404000	EMBELLEC. ADHESIVO AQUATEC	TRIM ADHESIVE AQUATEC	1						
	Z208734000	FRENTE EXTRAIBLE ASPES	ASPES DETACHABLE FRONT	1						
	Z214902000	BOTON DE MANDO	CONTROL BUTTON	2						
	R693055000	PILOTO VERDE 41227000C7	GREEN PILOT 41227000C7	1						
	Z204405000	FOLL. INSTRUCCIONES AQUATEC	INSTRUCT. LEAFLET AQUATEC	1						

FI-30, Fv34C, Gx14C, Lp300C, Rp14C, A320, Fi-30T, KM-30, CLV-30, BYM-500, EMP-500, DBM-500, MLV-50

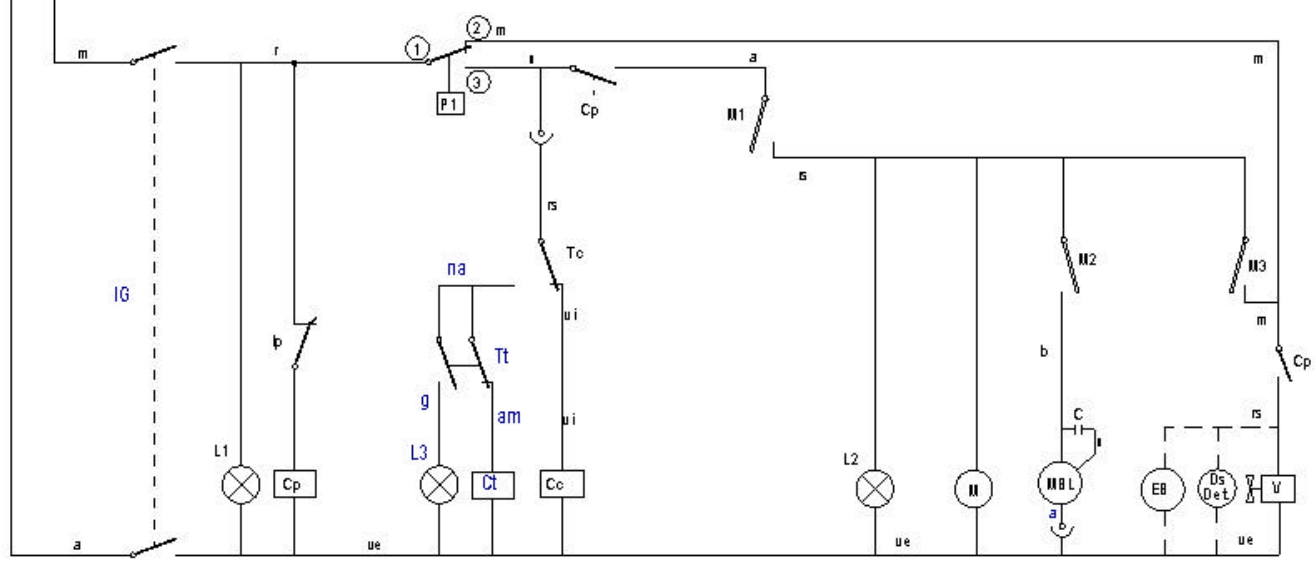
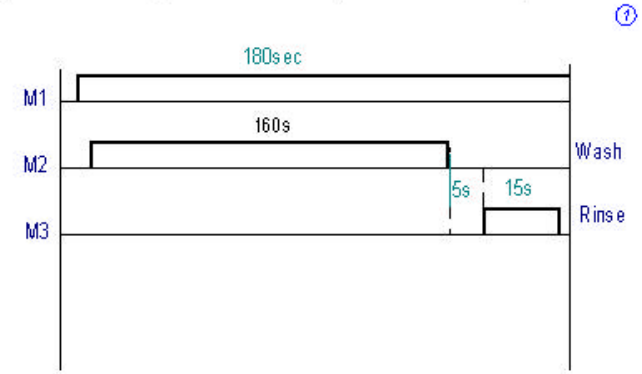
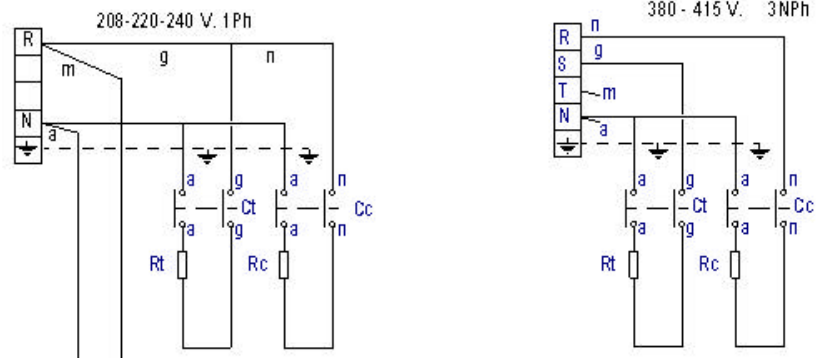

Z203077000

Esquema Teórico FI-30		Z203077000	
Nº	Pieza	Materia	Nº Clasificación
Nº	Modificación	Propósito de	Fecha
①	DBM-500 versión cart	revisión	2007-01-23
②	MOVILFRIT versión cart	modificación	2007-04-17
		Tolerancias generales	
		< 3%	50-100%
		5-25%	> 100%
		25-50%	∅%
Elaborado	M. Mallo	Fecha	07-10-2005
Dibujado	M. Mallo	Fecha	07-10-2005
Proyectado	M. Mallo	Fecha	07-10-2005
Comprobado	<i>[Signature]</i>	Fecha	07-10-2005
Escala			
<b>FAGOR</b>			Mecanizado superficial
LAVAVAJILLAS			Nº de pieza HC-17907-2
Para conocer el detalle de las tolerancias consultar el plano de fabricación			Substituye al N°
			Substituido por

# FI-30 B , A 320 B, LF-400 M-B

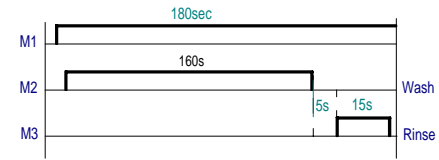
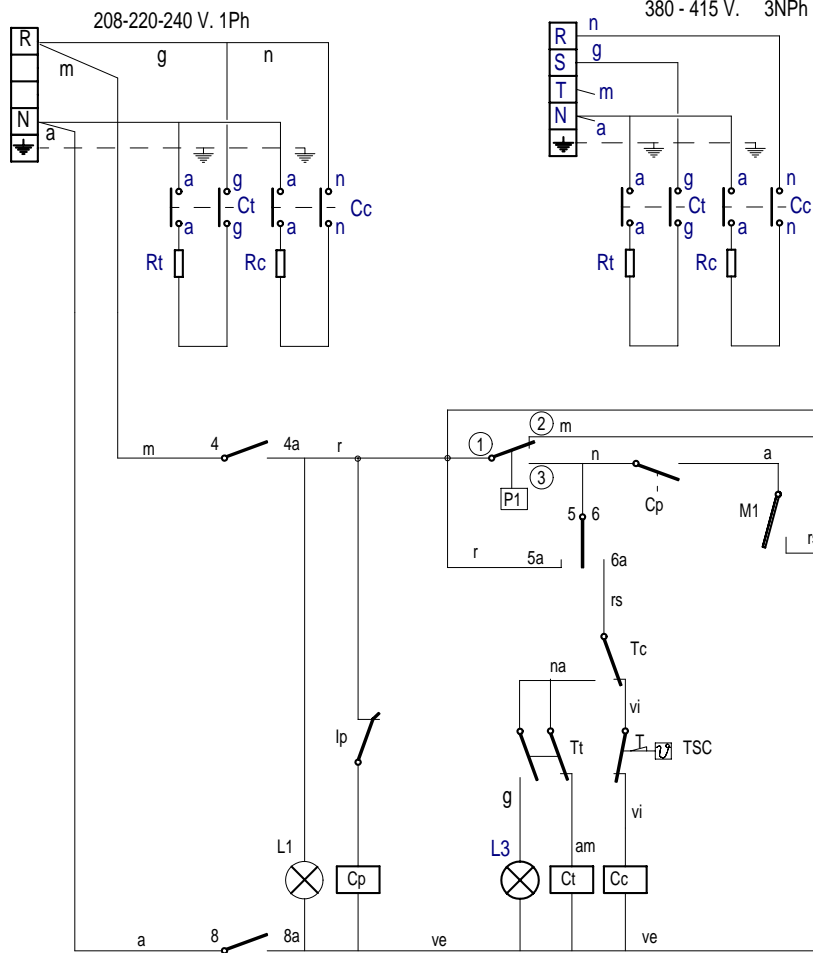

IG	1 1a	2 2a	4 4a	5 5a	6 6a	7 7a	8 8a
⏏		X	X	X			X
0							
⏏	X		X	X		X	X
	X		X		X	X	X

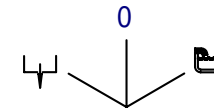

Z208810000

Esquema Teorico FI-30 B , A 320 B		Z208810000	
Nº	Pieza	Material	Nº Clasificacion
Nº	Modificacion	Propuesta de	Fecha
①	Añadir FI-30 B y actualizar colores	scaro	08-06-2007
②	Añadir LF-400 M-B	rbenito	21-04-2008
		Tolerancias generales	
		<5±	50-100±
		5-25±	>100±
		25-60±	∞±
Dibujado	Firma M.Maillo	Fecha 07-01-2006	Mecanizado superficial
Proyectado	M.Maillo	07-01-2006	
Comprobado	ENERITZ	07-01-2006	
Escala	FAGOR		Fagor Industrial,Koop.Elk, Mugatua
LAVAVAJILLAS			Plano numero HC-17924-2
Plano hau ez daiteke erabili ez berritza gure baimenitz gabe			Sustituye al Nº
			Sustituido por

# FI 30 B BT

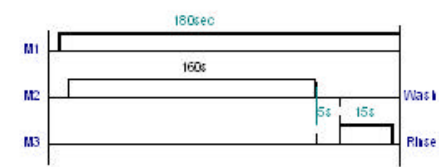
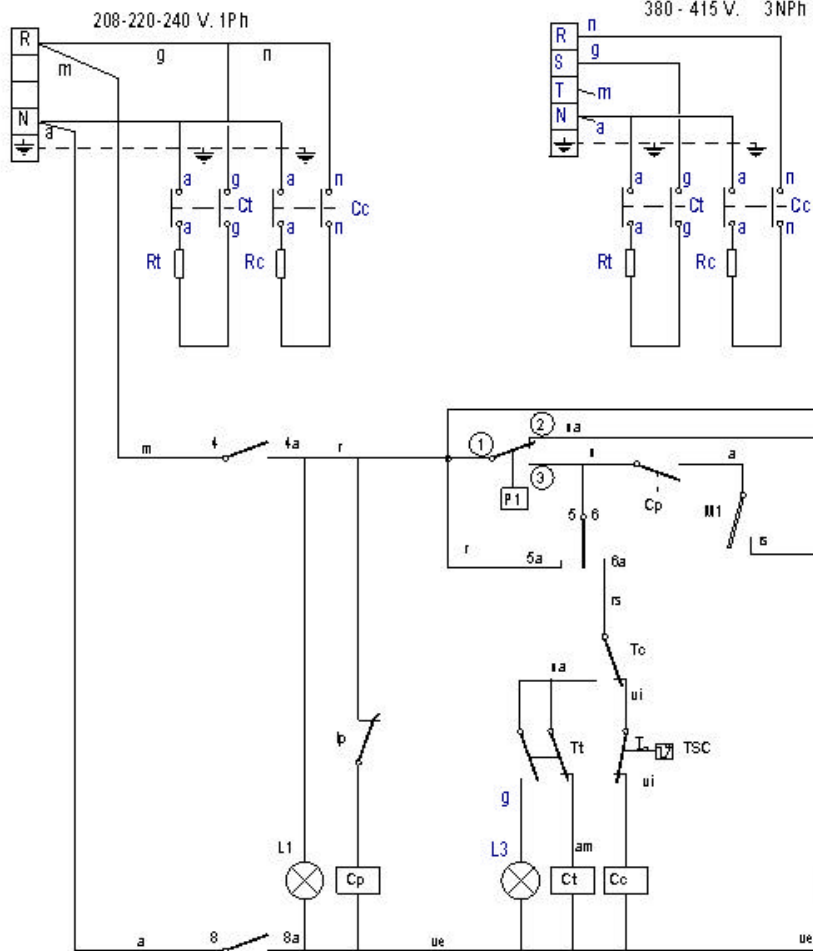

I G	1 1a	2 2a	4 4a	5 5a	6 6a	7 7a	8 8a
		x		x	x		x
			x	x		x	x
	x		x		x	x	x

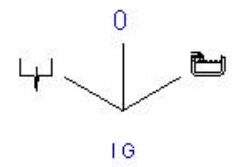

Z203082000

Esquema Teorico FI 30 B BT		Z203082000										
Nº Pieza	Materia	Nº Clasificación										
Nº Modificación	Propósito	Fecha										
		Tolerancias generales										
		< 3% : 5-100%										
		5-25% : > 100%										
		25-50% : < 4%										
<table border="1"> <tr> <td>Elaborado</td> <td>Fecha</td> </tr> <tr> <td>M. Mallo</td> <td>18-01-2007</td> </tr> <tr> <td>Proyectado</td> <td>M. Mallo</td> </tr> <tr> <td>Comprobado</td> <td>18-01-2007</td> </tr> <tr> <td>Escala</td> <td></td> </tr> </table>	Elaborado	Fecha	M. Mallo	18-01-2007	Proyectado	M. Mallo	Comprobado	18-01-2007	Escala		<p>Fagor Industrial,oop.EI. Megalga</p>	Mecanizado superficial
Elaborado	Fecha											
M. Mallo	18-01-2007											
Proyectado	M. Mallo											
Comprobado	18-01-2007											
Escala												
<p>LAVAVAJILLAS</p>		<p>Nº Pieza</p> <p>HC-18007</p>										
<p>Para conocer el significado de los símbolos consulte el manual de usuario.</p>		<p>Sustituya al N°</p> <p>Sustituya por</p>										

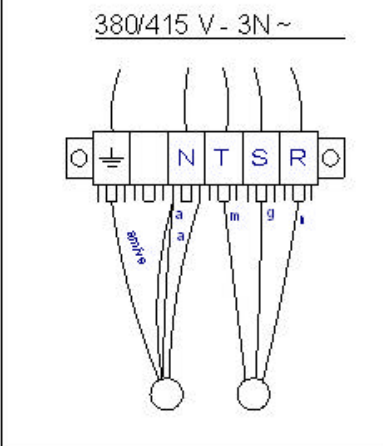
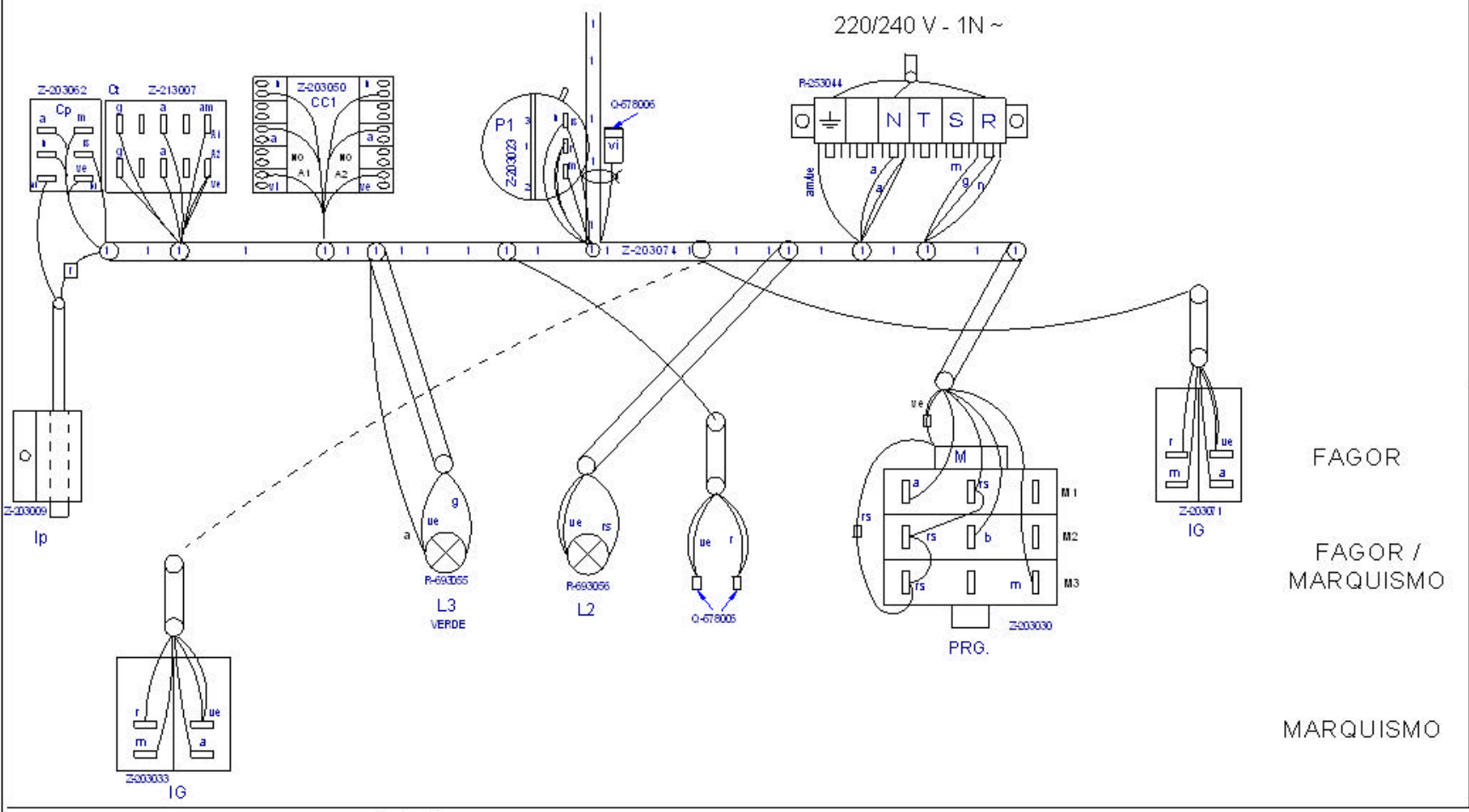

ESQUEMA TEORICO Z-203077  
 LEYENDA Z-243051  
 INDICADOR DE COMPONENTES Z-13034

FAGOR  
 FAGOR /  
 MARQUISMO  
 MARQUISMO

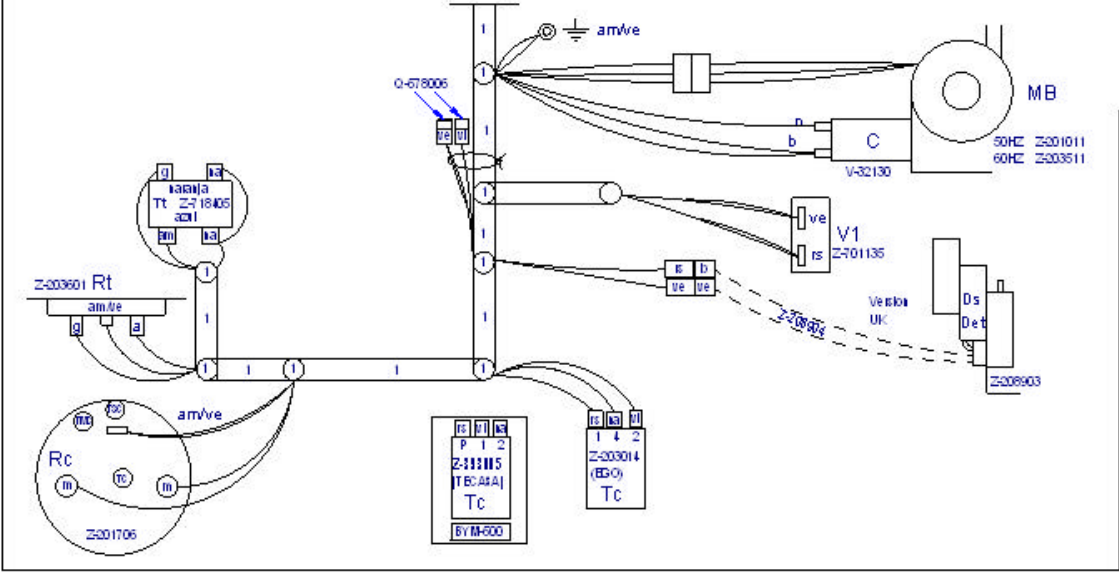

Plano Montaje FI-30		Z-203078000	
Nº	Pieza	Materia	Nº Clasificado
Nº	Modificación	Propósito de	Fecha
1	Corrección estética FAGOR	scara	2005-11-30
		Toleancias generales	
		< 3%	50-100%
		5-25%	> 100%
		25-50%	< 4

<table border="1"> <tr> <td>Elaborado</td> <td>M. Mallo</td> <td>07-10-2005</td> </tr> <tr> <td>Proyectado</td> <td>M. Mallo</td> <td>07-10-2005</td> </tr> <tr> <td>Comprobado</td> <td><i>[Signature]</i></td> <td>07-10-2005</td> </tr> <tr> <td>Escala</td> <td colspan="2"></td> </tr> </table>	Elaborado	M. Mallo	07-10-2005	Proyectado	M. Mallo	07-10-2005	Comprobado	<i>[Signature]</i>	07-10-2005	Escala			<p><b>FAGOR</b> </p> <p>Fagor Industrial, Coop. Ek. Meritxa</p>	<p>Mecanizado superficial</p> <p>Plano número <b>HC-17913 -1</b></p> <p>Sección a IN*</p> <p>Sección Ho por</p>
Elaborado	M. Mallo	07-10-2005												
Proyectado	M. Mallo	07-10-2005												
Comprobado	<i>[Signature]</i>	07-10-2005												
Escala														

LAVAVAJILLAS

Para conocer el detalle de los componentes consulte el manual de usuario.

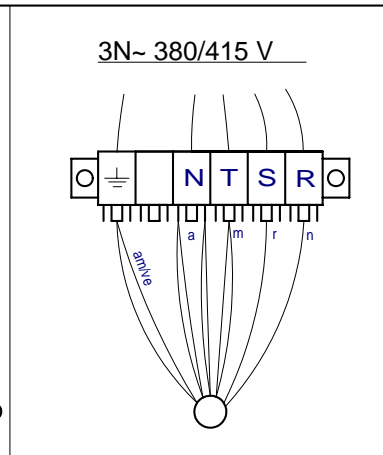
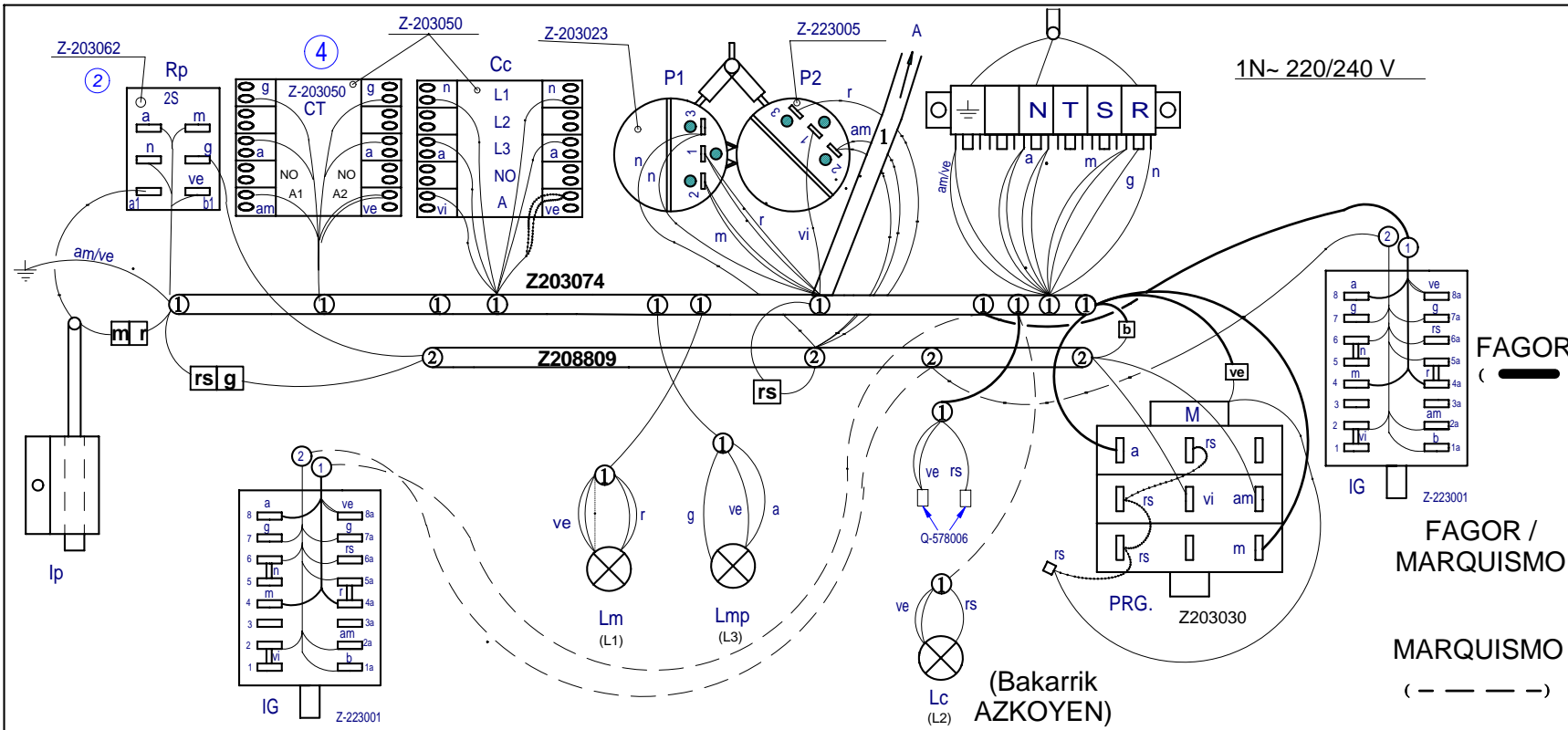

ESQUEMA TEORICO Z-208810  
 LEYENDA Z-243051  
 INDICADOR DE COMPONENTES Z-713034

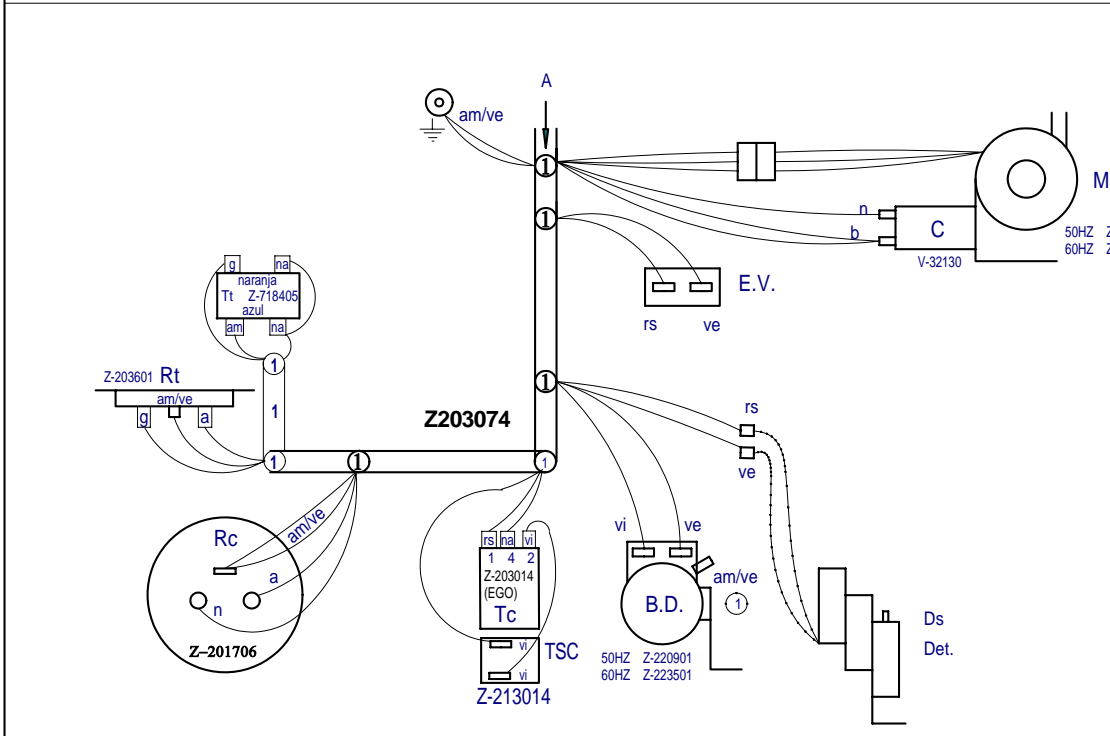

Esquema de montaje FI-30B		Z-208808			
Nº	Pieza	Cant.	Material	Nº Clasificación	Acabado
Nº	Modificación	Propuesta de		Fecha	Tolerancias generales
1	Añadir cable tierra en bomba desague	Santi		4-6-2001	$< 5 \pm$ $5-25 \pm$ $25-50 \pm$
2	Sustituir relé Z- 203018 por Z- 203062, cambiar colores en Rp	J.M.P.A.		2002-05-13	
3	Actualizar cableado Z203074 y Z208809. Modificación general.	scaro		2007-06-26	
4	Ct-ren erreferentzia aldatuta, Z203050 kendu da eta Z213007 jartzeko	e.carrascal		2008-09-05	$> 100 \pm$ $< \infty \pm$
5	Eguneratu	e.carrascal		2009-01-14	

Dibujado	Firma	Fecha		Mecanizado superficial
Proyectado	Santi Caro	07-07-00		Fagor Industrial,Koop.EIk, Mugatua
Comprobado				
Escala	<b>ONTZI-GARBIGAILUAK</b>			Plano numero
				HC-17264 -5
	Plano hau ez daiteke erabiliz ez berrizta gure baimeniz gabe			Sustituye al Nº
				HC-16331
				Sustituido por



# LEYENDA APERTURA FRONTAL

	ESPAÑOL	FRANÇAIS	ENGLISH	DEUTSCH	ITALIANO
BD	Bomba desagüe	Pompe de vidange	Drain pump	Abflußpumpe	Pompa scarico
C 1/2/3	Condensador	Condensateur	Condenser	Kondensator	Condensatore
CMB	Contactora bomba lavado	Contacteur pompe lavage	Wash pump contactor	Kontaktschütz Waschpumpe	Contattore pompa lavaggio
Cc 1/2	Contactora calentamiento calderin	Contacteur chauff. surchauffeur	Boiler heating contactor	Kontaktschütz Boilerheizung	Contattore riscaldamento boiler
Ct	Contactora calentamiento tanque	Contacteur chauffage cuve	Tank heating contactor	Kontaktschütz Heizung Tank	Contattore riscaldamento serbatoio
CP	Rele puerta	Relais porte	Door relay	Türrelais	Rele porta
Ds.Det.	Dosificador detergente	Dosseur de detergent	Detergent doser	Dosierer Spülmittel	Dosatore detersivo
E.B	Electrobomba de presion	Electropompe de pression	Electric pressure pump	Elektro-Drucksteigerungspumpe	Electropompa pressione
IG	Interruptor general	Interrupteur general	Main switch	Hauptschalter	Interruttore generale
IP	Micro puerta	Micro porte	Door microswitch	Mikroschalter Tür	Micro porta
L1	Piloto de encendido	Voyant fonctionnement	Operation light	Betriebsanzeigelampe	Spia accensione
L2	Piloto marcha	Voyant demarrage	Start light	Startanzeigelampe	Spia avvio
L3	Piloto maquina preparada	Voyant machine prêt	Light machine ready	Betriebsbereitschaftsanzeigelampe	Pilota macchina preparata
MBL	Bomba lavado	Pompe lavage	Wash pump	Waschpumpe	Pompa lavaggio
M	Motor programador	Moteur du programmeur	Motor programmer	Motor Programmiervorrichtung	Motore programmatore
M Av. R	Motor program. avance rapido	Moteur du progr.avance rapide	Motor program. rapid advance	Motor Programmiervorrich. schneller Vorlauf	Motore programmatore avanzamento rapido
M1	Micro programador marcha	Micro du programm. de marche	Micro programmer on	Motor Programmiervorrich. Betrieb	Micro programma. di funzionamento
M2	Micro programador lavado	Micro du programm. de lavage	Micro programmer wash	Motor Programmiervorrich. Waschen	Micro programmatore di lavaggio
M3	Micro programador aclarado	Micro du programm. de rinçage	Micro programmer on	Motor Programmiervorrich. Spülen	Micro programmatore di risciacquo
M4	Micro programador Termo-stop	Micro du programm. Thermo-stop	Micro programmer Thermo-stop	Motor Programmiervorrich. Thermo-Stop	Micro programmatore Thermo-stop
M5	Micro programador avance	Micro du programm. avance	Micro programmer advance	Motor Programmiervorrich. Vorlauf	Micro programmatore avanzamento
P, P1, P5	Presostato	Pressostat	Pressure switch	Druckwächter	Pressostato
P2, P3, P4	Presostato limitador	Pressostat de securité	Hi-limit pressure switch	Begrenzer Druckwächter	Pressostato limitatore
RC	Resistencia calderin	Resistance surchauffeur	Boiler heating element	Heizwiderstand Boiler	Resistenza boiler
RT	Resistencia tanque	Resistance cuve	Tank heater	Heizwiderstand Tank	Resistenza serbatoio
Tt	Termostato tanque	Thermostat de cuve	Tank thermostat	Thermostat Tank	Termostato serbatoio
TC	Termostato calderin	Thermostat surchauffeur	Boiler thermostat	Thermostat kessel	Termostato boiler
TSC	Limitador calderin	Limiteur surchauffeur	Boiler Hi-limit	Begrenzer Boiler	Limitatore boiler
TSTP	Termostato termo-stop	Thermostat Thermo-stop	Thermo-stop Thermostat	Thermostat Thermo-stop	Termostato Thermo-stop
V	Electrovalvula llenado y aclarado	Electrovan. remplissage rinçage	Fill and rinse valve	Elektroventil Füllen und Spülen	Elettroval. riempimento e risciacquo
COLOR	COLORES	COULEURS	COLOUR	FARBEN	COLORE
a =	Azul	Bleu	Blue	Blau	Blu
am =	Amarillo	Jaune	Yellow	Gelb	Giallo
am/ve =	Amarillo/verde	Jaune / vert	Yellow / green	Gelb/grün	Giallo/verde
b =	Blanco	Blanc	White	Weiß	Bianco
g =	Gris	Gris	Grey	Grau	Grigio
m =	Marrón	Marron	Brown	Braun	Marrone
n =	Negro	Noir	Black	Schwarz	Nero
na =	Naranja	Orange	Orange	Orange	Arancio
r =	Rojo	Rouge	Red	Rot	Rosso
rs =	Rosa	Rose	Pink	Rosa	Roseo
ve =	Verde	Vert	Green	Grün	Verde
vi =	Violeta	Violet	Purple	Violett	Viola

Z243051000