

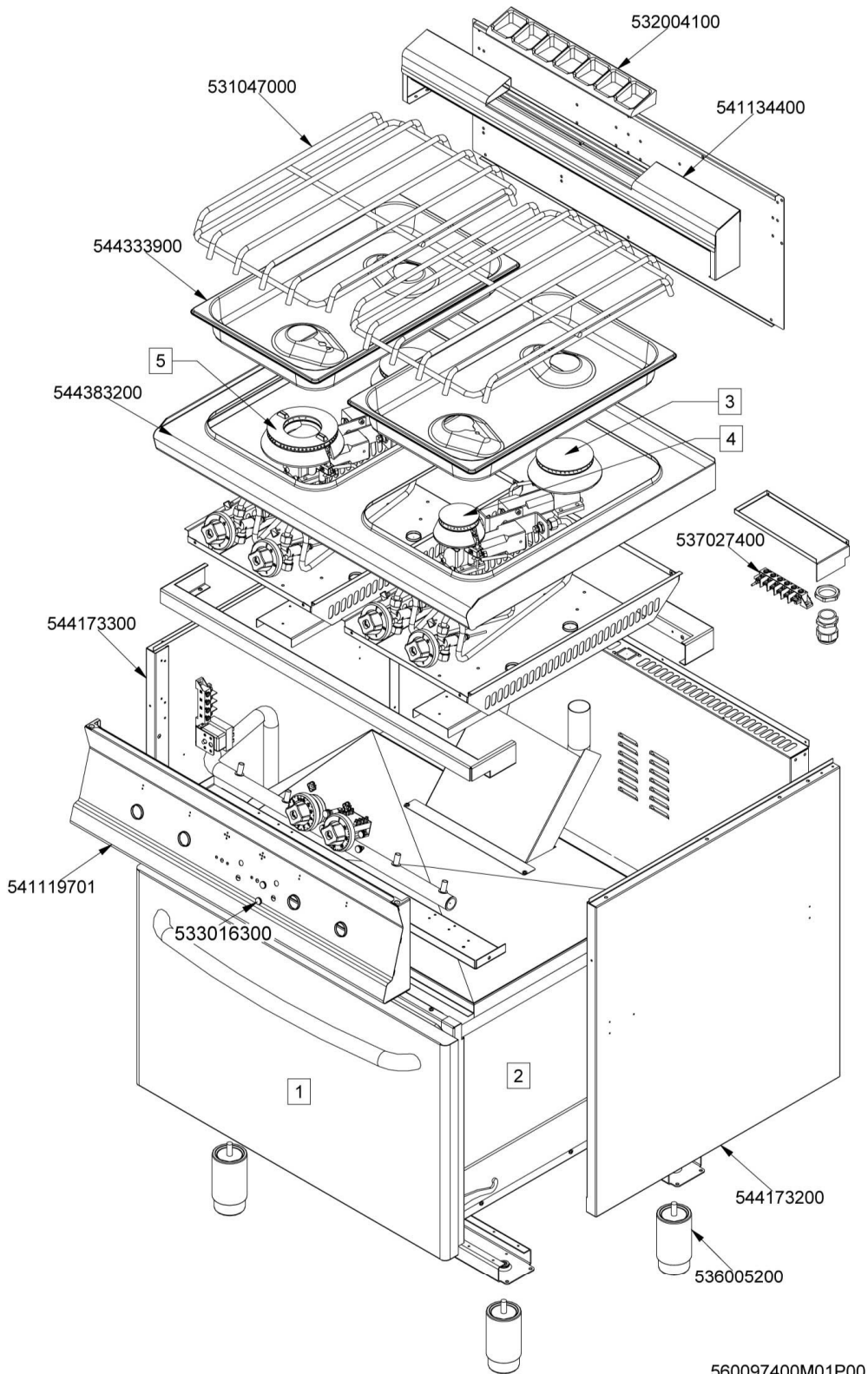

CFV4-78GPE (SN>=1201<=1604)
Tav. 560097400M01P00



560097400M01P00



CFV4-78GPE (SN>=1201<=1604) - CUCINE CFV4-78GPE

Codice	Descrizione
532004100	GRIGLIA SC.FUMI L370 SMALT.RAF
531047000	GRIGLIA PC S70 2F.TOND.
541134400	ASS.DIST.S70 BASS.7 8 1 GRI.CX
544333900	BAC.BRU.S70 PC GN1/1 2 B.R UR
544383200	PIANO S70 PC-7 8GP CF4-78GP/GPE (T)
537027400	MORSETT.6 POLI 40A VITE-VITE
544173300	FIANCO APP.S70M CF SX
541119701	ASS.CRUSC.S607090 CF4-98GE
533016300	PERNO BOCCOLA RUB.
536005200	PIEDE Ø2" 120-180 M10 INOX
544173200	FIANCO APP.S70M CF DX
-	-
-	-
-	-
-	-
-	-



FORNO S70 S90 GN2/1 PORTA INOX
Tav. 560099800M00P00

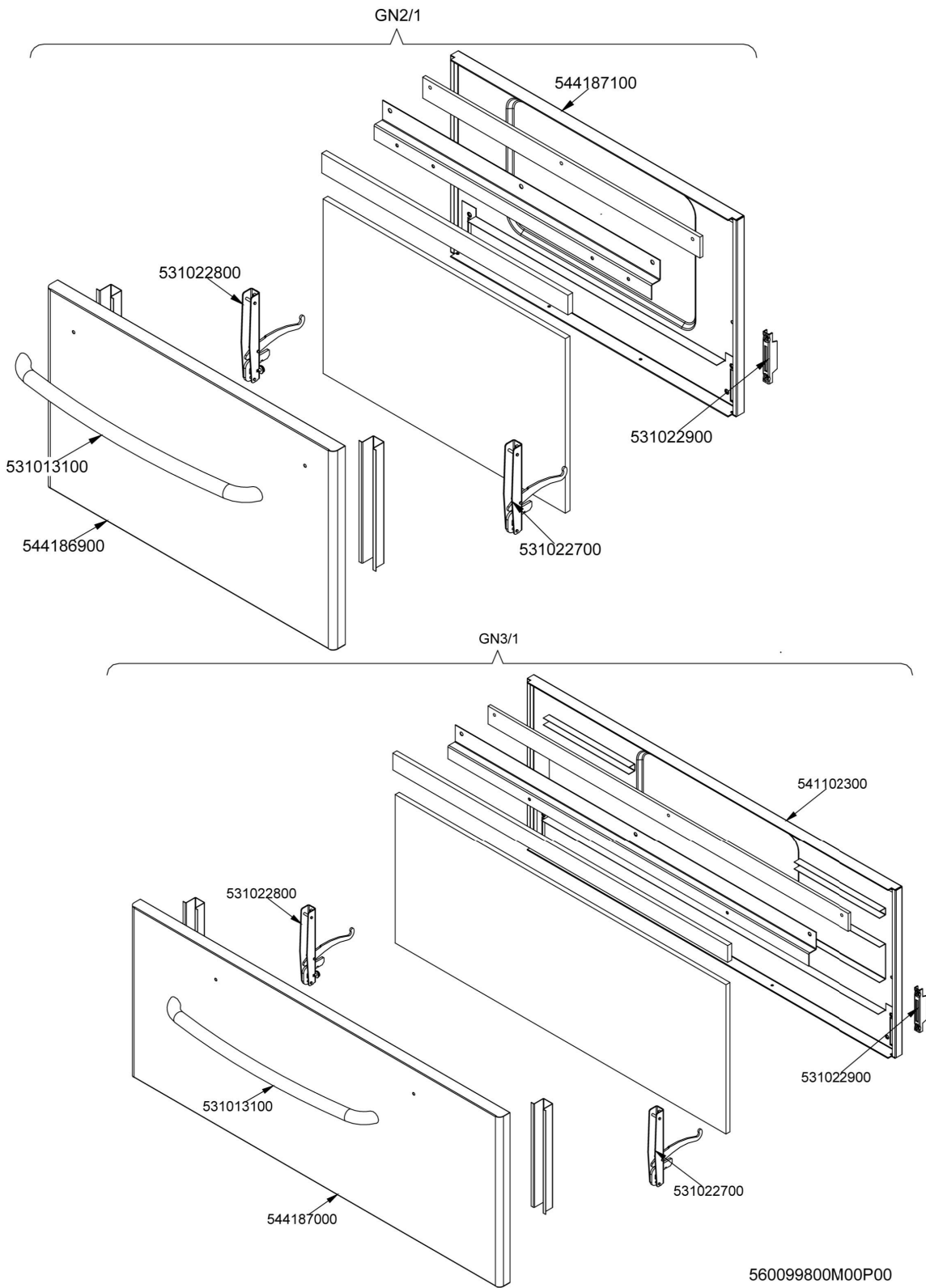



FORNO S70 S90 GN2/1 PORTA INOX - FORNO PORTE_IPERLOTUS

Codice	Descrizione
_GN2/1	CODICE IN ELABORAZIONE
544187100	CONTROP.FORNO GN2/1 S70/90
531022800	CERNIERA PORTA F.Ø4 S70/90 DX
531013100	MANIGLIA PORTA FORNO S70/90 INOX
544186900	PORTA FORNO GN2/1 S70/90
531022700	CERNIERA PORTA F.Ø4 S70/90 SX
531022900	PORTARULL.CERN.PORTA F.S70/90
GN3/1	CODICE IN ELABORAZIONE
541102300	ASS.CONTROP.FORNO GN3/1 S70
531022800	CERNIERA PORTA F.Ø4 S70/90 DX
531013100	MANIGLIA PORTA FORNO S70/90 INOX
544187000	PORTA FORNO GN3/1 S70/90
531022700	CERNIERA PORTA F.Ø4 S70/90 SX
531022900	PORTARULL.CERN.PORTA F.S70/90



FORNO S70 S90 GN1/1 ELETTRICO VENTILATO CARCASSA
Tav. 560095100M00P00

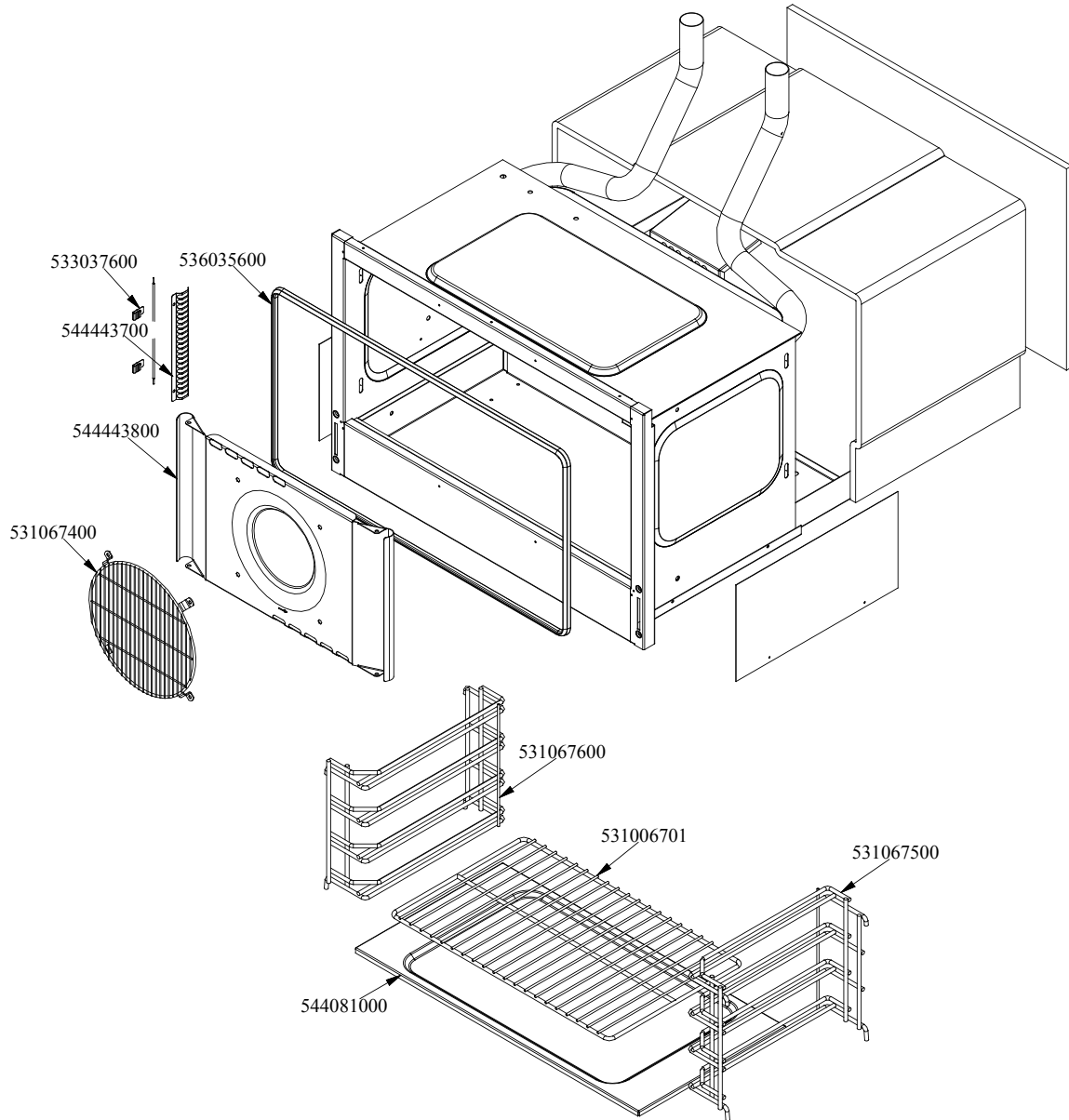

5600951 00M00P00



FORNO S70 S90 GN1/1 ELETTRICO VENTILATO CARCASSA - COMPONENTI COMUNI
ELETTRICOVENTILATO

Codice	Descrizione
533037600	MOLLA FISS.BULB.Ø3/Ø4 PIATTA BR.
536035600	GUARNIZ.FORNO GN1/1 S70/90 VENT.
544443800	PANN.DIFF.ARIA.F.VENT.S70
531067400	GRIGLIA PROT.VENT.FORN.VENT.S70
531067600	PORTAGRIGLIA FORNO S70 SX GN1/1
531006701	GRIGLIA FORNO MAXI S60T/65/60
531067500	PORTAGRIGLIA FORNO S70 DX GN1/1
544081000	SUOLA FORNO EL.GN1/1 S55
544443700	PROTEZIONE BULBO FORNO VENTILATO



MFV-78ET (SN>=1201<=1604)
Tav. 560095200M01P00

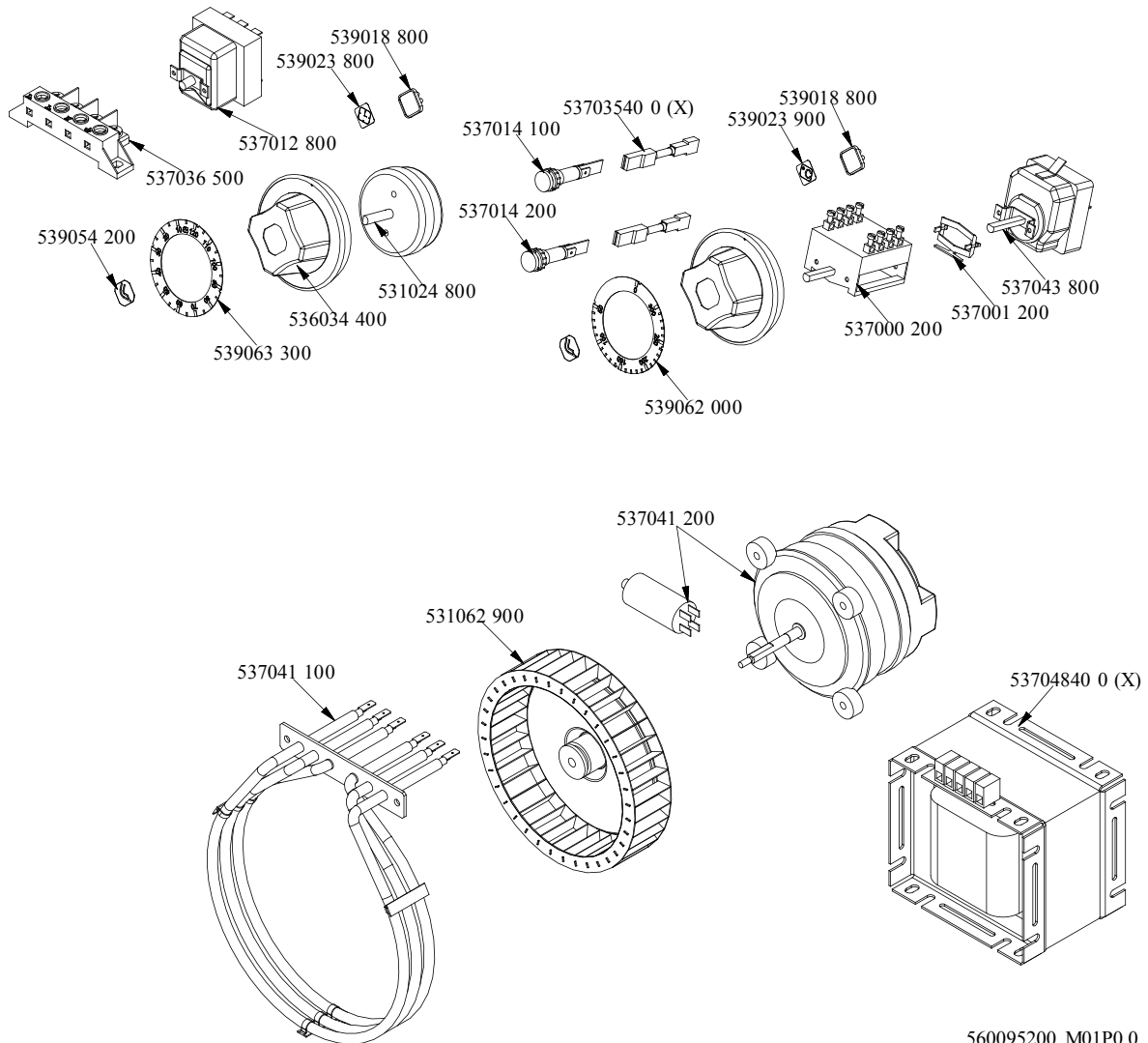

560095200 M01P0 0



MFV-78ET (SN>=1201<=1604) - BASE CON FORNO ELTTRICO VENTILATO MFV-78ET

Codice	Descrizione
539054200	BOLLINO Ø20,3 CR."L" LOTUS R.
537036500	MORSETT.4 POLI 40A VITE-VITE
537012800	TERMOST.SIC.TRIF. 420°C
539023800	ET.AD.IND.TYMER FORNO
539018800	INDICE MAN.C/VANO ETICHETTA
539063300	DISC.72.TYMER MECCANICO
536034400	MANOP.Ø77 4 P.Ø06X4,6 NERO C/M
531024800	TIMER MECCANICO 120'
537014200	SPIA G.B.VERDE 250VAC F.M.
537014100	SPIA G.B.BIANC.250VAC F.M.
539023900	ET.AD.IND.TEMPERATURA FORNO
539018800	INDICE MAN.C/VANO ETICHETTA
537043800	TERMOST.F.TRIF. 048-300°C GAMB.L
537001200	STAFF.FISS.COMM.S49 TERMOST.3,5
537000200	COMM.1 POS.3F 16A
539062000	DISC.72.FORN.S70 E.ST.TERM.
537041100	RES.COR.FOR.VENT 5200W 3-230V
531062900	VENTOLA Ø180 FORNO VENTIL.S70
537041200	MOTOVENT.FORNO VENT. S70 C/COND.



COMANDO E BRUCIATORE PC-G S70 2R (SN<=1604)
Tav. 560038600M02P00

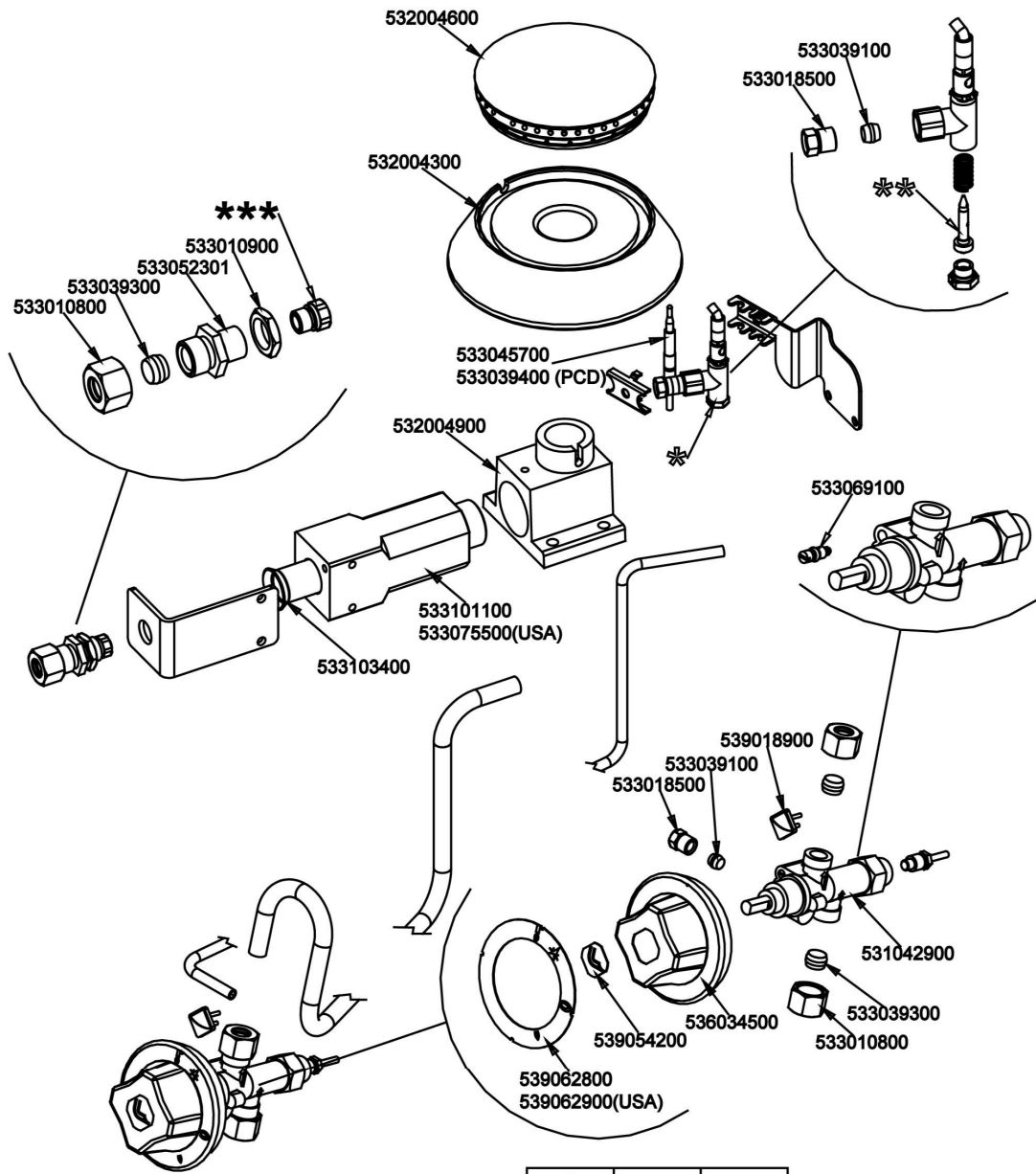

	*	**	***
G30-28+30mbar G31- 37mbar	533091400	533091000	533043900
G30- 50mbar	533091400	533091000	533019300
G20- 20mbar G25- 25mbar	533091500	533091200	533031000
G20- 20mbar DE-AT	533091500	533091200	533031000
G25- 20mbar	533091500	533091200	533043500
G25- 25mbar NL	533091500	533091200	533019400
GAS E-10IWC USA	533091400	533091000	533043200
GAS A-4IWC USA	533161200	533091300	533043100
G31- 2,49kPa AUS	533091400	533091000	533043900
G20- 1kPa AUS	533161200	533091300	533043500

560038600M02P00



COMANDO E BRUCIATORE PC-G S70 2R (SN<=1604) - COMPONENTI COMUNI COMAN
G_R_S70

Codice	Descrizione
532004600	SPARTIF.CORONA Ø104 NICH. S70
533039100	BICONO Ø06
533018500	RACC.BIC.Ø06 M10X1
532004300	CORPO BRU.A1 5,5KW NICH. S70
533010900	DADO ES.M14X1 OT
533052301	RACC.PORTAINIETT. 0°CANN.Ø10
533039300	BICONO Ø10
533010800	DADO ES.X BIC.Ø10 M16X1,5
533045700	TC G.UNI 0500
533039400	TC G.UNI 0850
532004900	GOMITO BRUCIATORE 5,5KW
533069100	BY-P.RUB.20S-21S Ø060
533101100	VENTURI BRU.A1 5,5KW S70
533075500	VENTURI BRU.A1 5,5KW S70 USA
533103400	BOCCOLA REG.ARIA Ø20 EST.ALT.57
539018900	INDICE MAN.C/FRECCIA ROSSA
533039100	BICONO Ø06
533018500	RACC.BIC.Ø06 M10X1
531042900	RUB.GAS 21S P.V.BY-P.Ø060
533034500	CODICE IN ELABORAZIONE
539054200	BOLLINO Ø20,3 CR."L" LOTUS R.
533039300	BICONO Ø10
533010800	DADO ES.X BIC.Ø10 M16X1,5
539062800	DISC.72.PC-GP R.
539062900	DISC.72.PC-GP R. USA
533091400	PILOTA 0100 1F RACC.BIC.UG.Ø20
533091500	PILOTA 0100 1F RACC.BIC.UG.Ø35
533161200	PILOTA 0100 1F RACC.BIC.UG.Ø40
533091000	UGELLO PILOTA 0100 Ø20 PIL.PC
533091200	UGELLO PILOTA 0100 Ø35 PIL.PC
533091300	UGELLO PILOTA 0100 Ø40 PIL.PC
533043900	INIETTORE CH12X14,0 Ø115
533019300	INIETTORE CH12X14,0 Ø100
533031000	INIETTORE CH12X14,0 Ø175
533043500	INIETTORE CH12X14,0 Ø190
533019400	INIETTORE CH12X14,0 Ø180
533043200	INIETTORE CH12X14,0 Ø110
533043100	INIETTORE CH12X14,0 Ø185
533043900	INIETTORE CH12X14,0 Ø115
533043500	INIETTORE CH12X14,0 Ø190



COMANDO E BRUCIATORE PC-G S70 3SR (SN<=1604)
Tav. 560038500M02P00

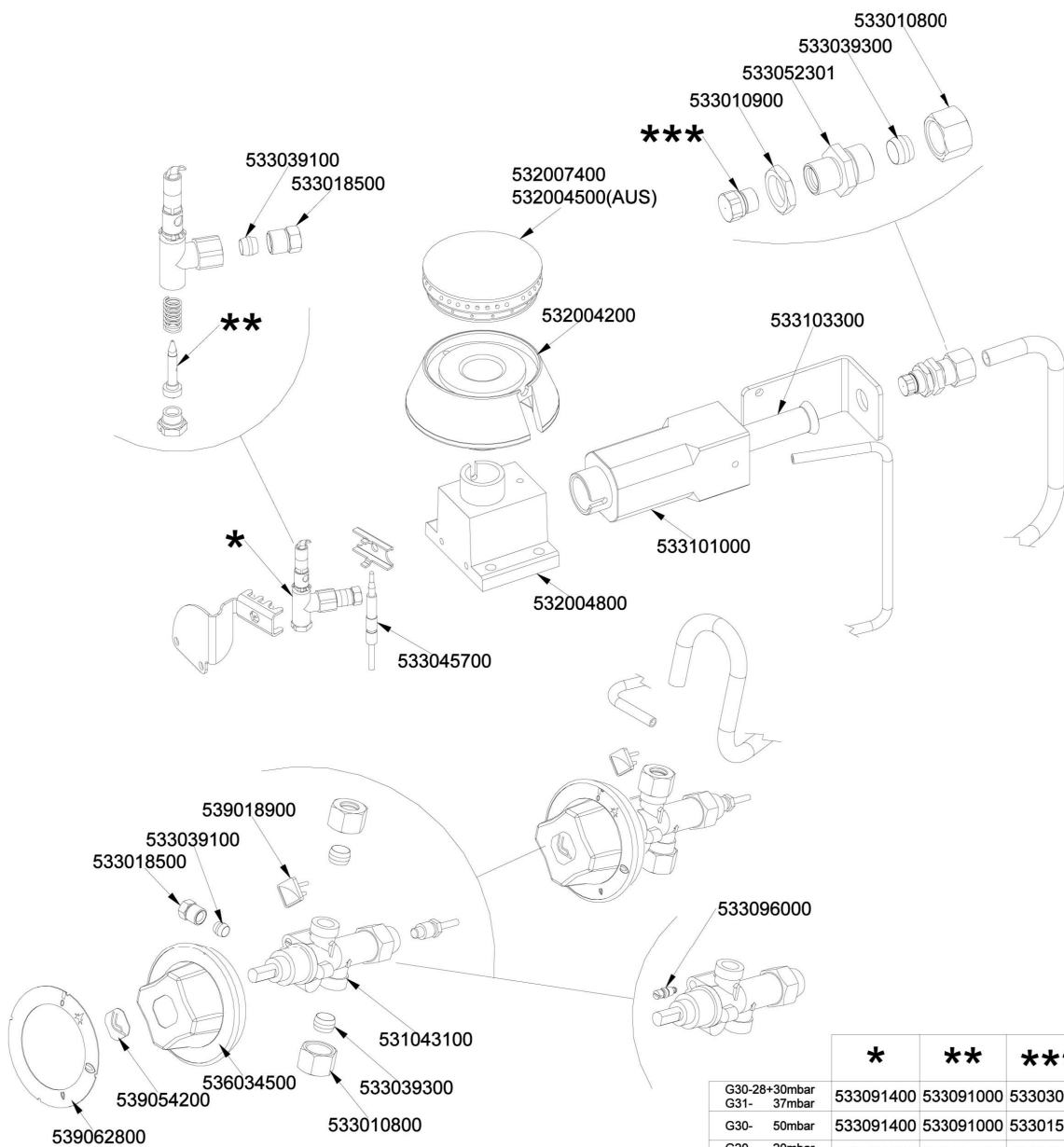

	*	**	***
G30-28+30mbar	533091400	533091000	5330305
G31- 37mbar			
G30- 50mbar	533091400	533091000	5330151
G20- 20mbar	533091500	533091200	5330152
G25- 25mbar			
G20- 20mbar DE-AT	533091500	533091200	5330152
G25- 20mbar	533091500	533091200	5330308
G25- 25mbar NL	533091500	533091200	5330149
G31- 2,49kPa AUS	533091400	533091000	5330193
G20- 1kPa AUS	533161200	533091300	5330303

560038500M02F



COMANDO E BRUCIATORE PC-G S70 3SR (SN<=1604) - COMPONENTI COMUNI COMA
G_SR_S70

Codice	Descrizione
533010800	DADO ES.X BIC.Ø10 M16X1,5
533039300	BICONO Ø10
533052301	RACC.PORTAINIETT. 0°CANN.Ø10
533010900	DADO ES.M14X1 OT
533039100	BICONO Ø06
532007400	SPARTIF.CORONA Ø073 4 Z NICS70
533018500	RACC.BIC.Ø06 M10X1
532004500	SPARTIF.CORONA Ø073 NICH. S70K
532004200	CORPO BRU.A1 3,5KW NICH. S70
533103300	BOCCOLA REG.ARIA Ø16 EST.ALT.57
533101000	VENTURI BRU.A1 3,5KW S70
532004800	GOMITO BRUCIATORE 3,5KW
533045700	TC G.UNI 0500
539018900	INDICE MAN.C/FRECCIA ROSSA
533039100	BICONO Ø06
533018500	RACC.BIC.Ø06 M10X1
533096000	BY-P.RUB.20S-21S Ø050
531043100	RUB.GAS 21S P.V.BY-P.Ø050
539054200	BOLLINO Ø20,3 CR."L" LOTUS R.
533039300	BICONO Ø10
536034500	MANOP.Ø77 4 P.Ø08X6,5 NERO
539062800	DISC.72.PC-GP R.
533010800	DADO ES.X BIC.Ø10 M16X1,5
533091400	PILOTA 0100 1F RACC.BIC.UG.Ø20
533091500	PILOTA 0100 1F RACC.BIC.UG.Ø35
533091400	PILOTA 0100 1F RACC.BIC.UG.Ø20
533161200	PILOTA 0100 1F RACC.BIC.UG.Ø40
533091000	UGELLO PILOTA 0100 Ø20 PIL.PC
533091200	UGELLO PILOTA 0100 Ø35 PIL.PC
533091000	UGELLO PILOTA 0100 Ø20 PIL.PC
533091300	UGELLO PILOTA 0100 Ø40 PIL.PC
533030500	INIETTORE CH12X14,0 Ø090
533015100	INIETTORE CH12X14,0 Ø080
533015200	INIETTORE CH12X14,0 Ø145
533030800	INIETTORE CH12X14,0 Ø155
533014900	INIETTORE CH12X14,0 Ø150
533019300	INIETTORE CH12X14,0 Ø100
533030300	INIETTORE CH12X14,0 Ø160



COMANDO E BRUCIATORE PC-G S70 1UR (SN<=1604)
 Tav. 560038700M02P00

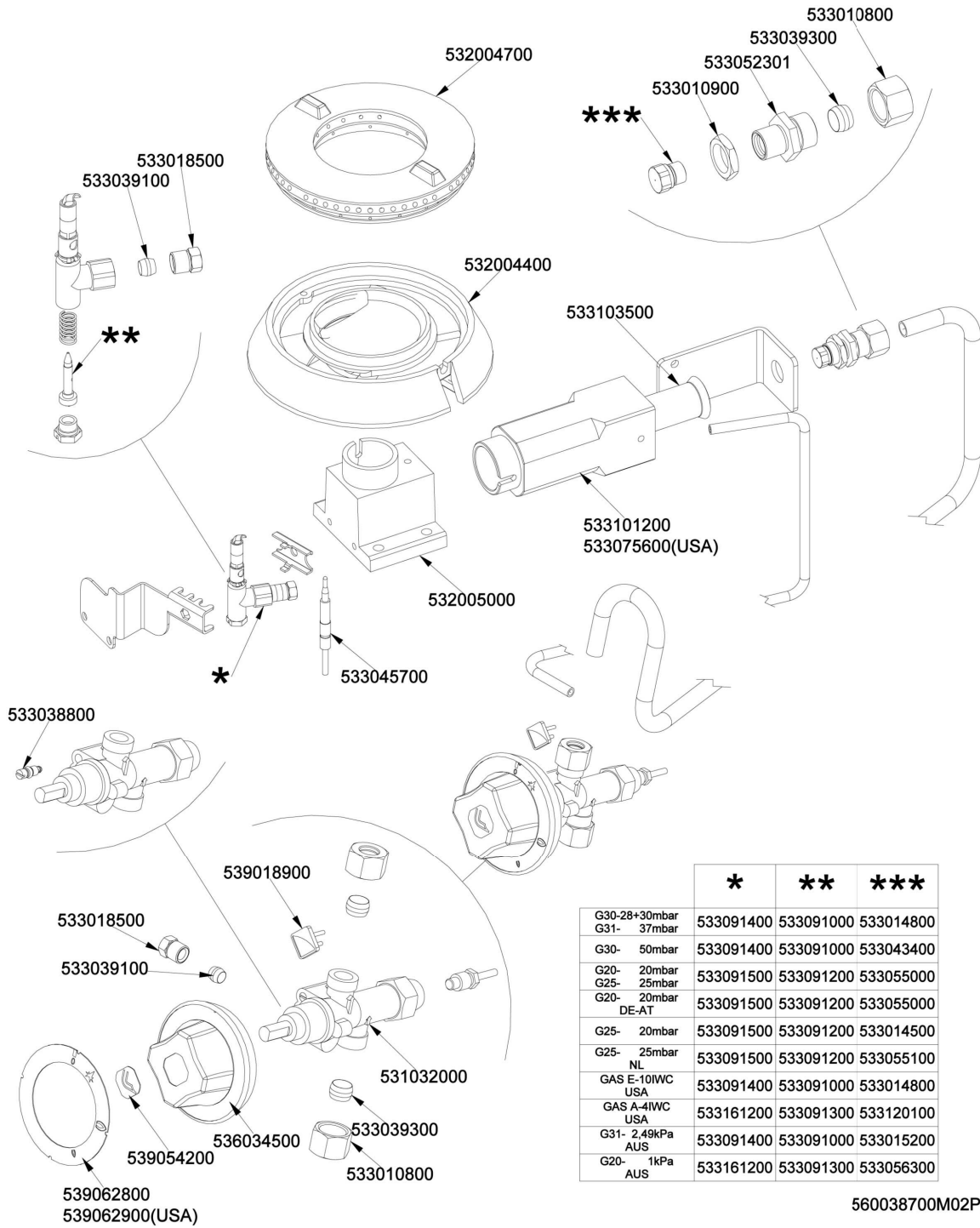

	*	**	***
G30-28+30mbar	533091400	533091000	533014800
G31- 37mbar	533091400	533091000	533043400
G30- 50mbar	533091400	533091000	533043400
G20- 20mbar	533091500	533091200	533055000
G25- 25mbar	533091500	533091200	533055000
G20- 20mbar DE-AT	533091500	533091200	533055000
G25- 20mbar	533091500	533091200	533014500
G25- 25mbar NL	533091500	533091200	533055100
GAS E-10IWC USA	533091400	533091000	533014800
GAS A-4IWC USA	533161200	533091300	533120100
G31- 2,49kPa AUS	533091400	533091000	533015200
G20- 1kPa AUS	533161200	533091300	533056300

560038700M02P00



COMANDO E BRUCIATORE PC-G S70 1UR (SN<=1604) - COMPONENTI COMUNI COMA
G_UR_S70

Codice	Descrizione
533010800	DADO ES.X BIC.Ø10 M16X1,5
533039300	BICONO Ø10
533052301	RACC.PORTAINIETT. 0°CANN.Ø10
532004700	SPARTIF.D.CORONA Ø128 NICH. S70
533010900	DADO ES.M14X1 OT
533018500	RACC.BIC.Ø06 M10X1
533039100	BICONO Ø06
532004400	CORPO BRU.A1 7,5KW NICH. S70
533103500	BOCCOLA REG.ARIA Ø22 EST.ALT.57
533101200	VENTURI BRU.A1 7,5KW S70
533075600	VENTURI BRU.A1 7,5KW S70 USA
532005000	GOMITO BRUCIATORE 7,5KW
533045700	TC G.UNI 0500
533038800	BY-P.RUB.20S-21S Ø075
539018900	INDICE MAN.C/FRECCIA ROSSA
533018500	RACC.BIC.Ø06 M10X1
533039100	BICONO Ø06
531032000	RUB.GAS 21S P.V.BY-P.Ø075
536034500	MANOP.Ø77 4 P.Ø08X6,5 NERO
533039300	BICONO Ø10
539054200	BOLLINO Ø20,3 CR."L" LOTUS R.
533010800	DADO ES.X BIC.Ø10 M16X1,5
539062800	DISC.72.PC-GP R.
539062900	DISC.72.PC-GP R. USA
533091400	PILOTA 0100 1F RACC.BIC.UG.Ø20
533091500	PILOTA 0100 1F RACC.BIC.UG.Ø35
533161200	PILOTA 0100 1F RACC.BIC.UG.Ø40
533091000	UGELLO PILOTA 0100 Ø20 PIL.PC
533091200	UGELLO PILOTA 0100 Ø35 PIL.PC
533091300	UGELLO PILOTA 0100 Ø40 PIL.PC
533014800	INIETTORE CH12X14,0 Ø135
533043400	INIETTORE CH12X14,0 Ø117
533055000	INIETTORE CH12X14,0 Ø205
533014500	INIETTORE CH12X14,0 Ø225
533055100	INIETTORE CH12X14,0 Ø215
533014800	INIETTORE CH12X14,0 Ø135
533120100	INIETTORE CH12X14,0 Ø210
533015200	INIETTORE CH12X14,0 Ø145
533056300	INIETTORE CH12X14,0 Ø240