

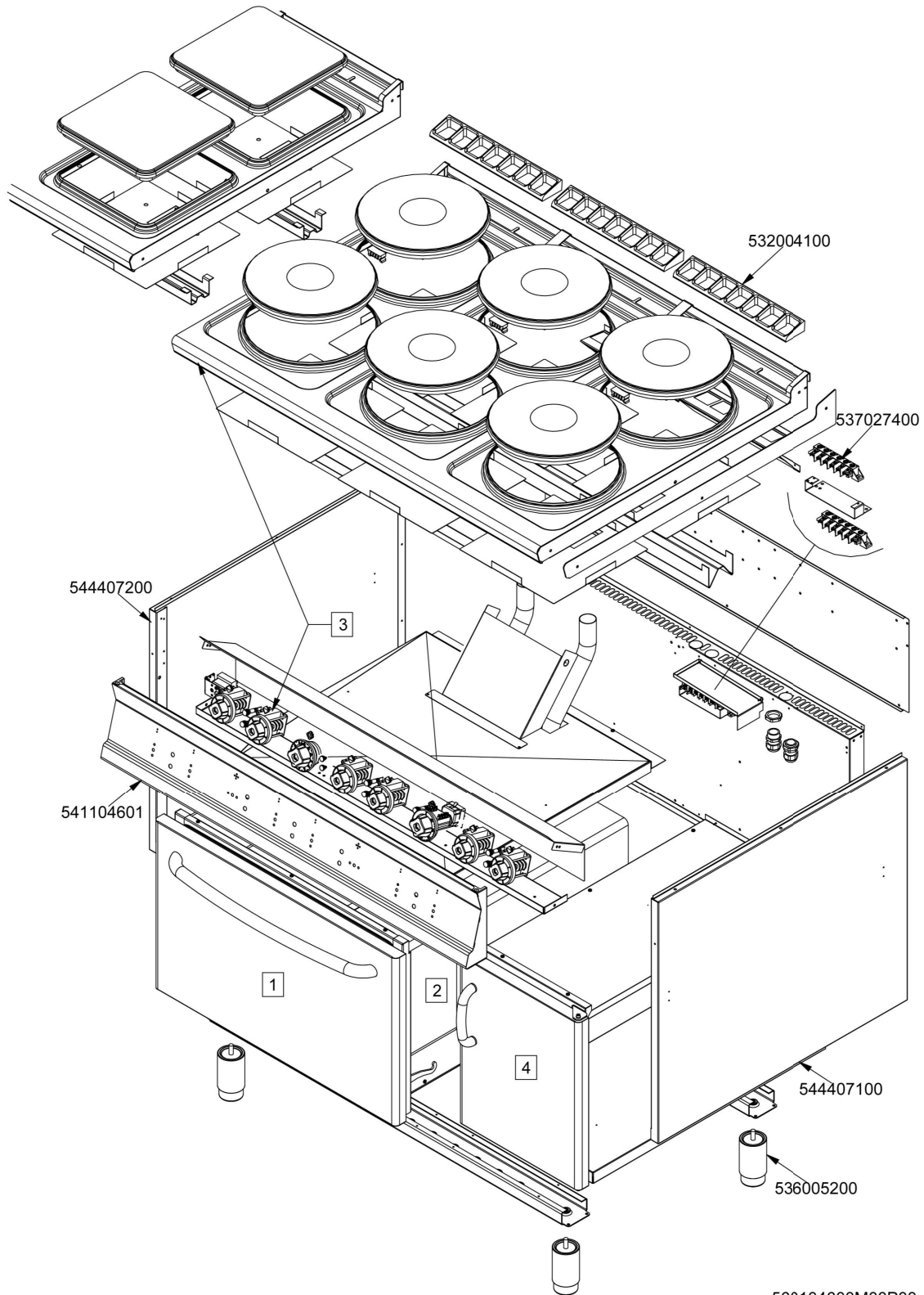

CFV6-912ETV (SN>=1201<=1604)  
Tav. 560104600M00P00



560104600M00P00



CFV6-912ETV (SN>=1201<=1604) - CUCINE CFV6-912ETV

Codice	Descrizione
532004100	GRIGLIA SC.FUMI L370 SMALT.RAF
537027400	MORSETT.6 POLI 40A VITE-VITE
544407200	FIANCO APP.S90M CF SX
541104601	ASS.CRUSC.S607090 CF6-912E/EV
544407100	FIANCO APP.S90M CF DX
536005200	PIEDE Ø2" 120-180 M10 INOX
-	-
-	-
-	-
-	-



FORNO S70 S90 GN2/1 PORTA INOX  
Tav. 560099800M00P00

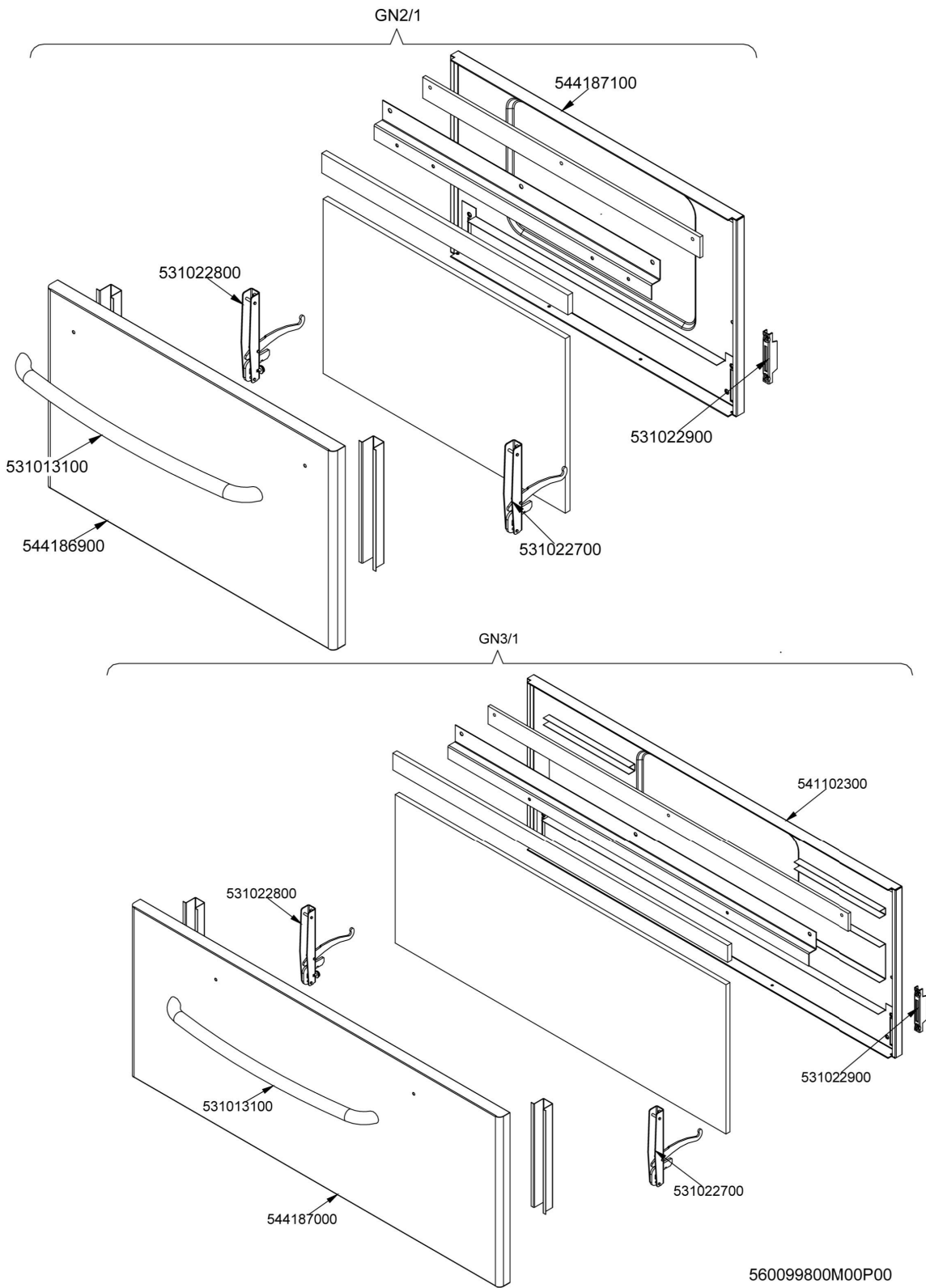



FORNO S70 S90 GN2/1 PORTA INOX - FORNO PORTE\_IPERLOTUS

Codice	Descrizione
_GN2/1	CODICE IN ELABORAZIONE
544187100	CONTROP.FORNO GN2/1 S70/90
531022800	CERNIERA PORTA F.Ø4 S70/90 DX
531013100	MANIGLIA PORTA FORNO S70/90 INOX
544186900	PORTA FORNO GN2/1 S70/90
531022700	CERNIERA PORTA F.Ø4 S70/90 SX
531022900	PORTARULL.CERN.PORTA F.S70/90
GN3/1	CODICE IN ELABORAZIONE
541102300	ASS.CONTROP.FORNO GN3/1 S70
531022800	CERNIERA PORTA F.Ø4 S70/90 DX
531013100	MANIGLIA PORTA FORNO S70/90 INOX
544187000	PORTA FORNO GN3/1 S70/90
531022700	CERNIERA PORTA F.Ø4 S70/90 SX
531022900	PORTARULL.CERN.PORTA F.S70/90



FORNO S70 S90 GN1/1 ELETTRICO VENTILATO CARCASSA  
Tav. 560095100M00P00

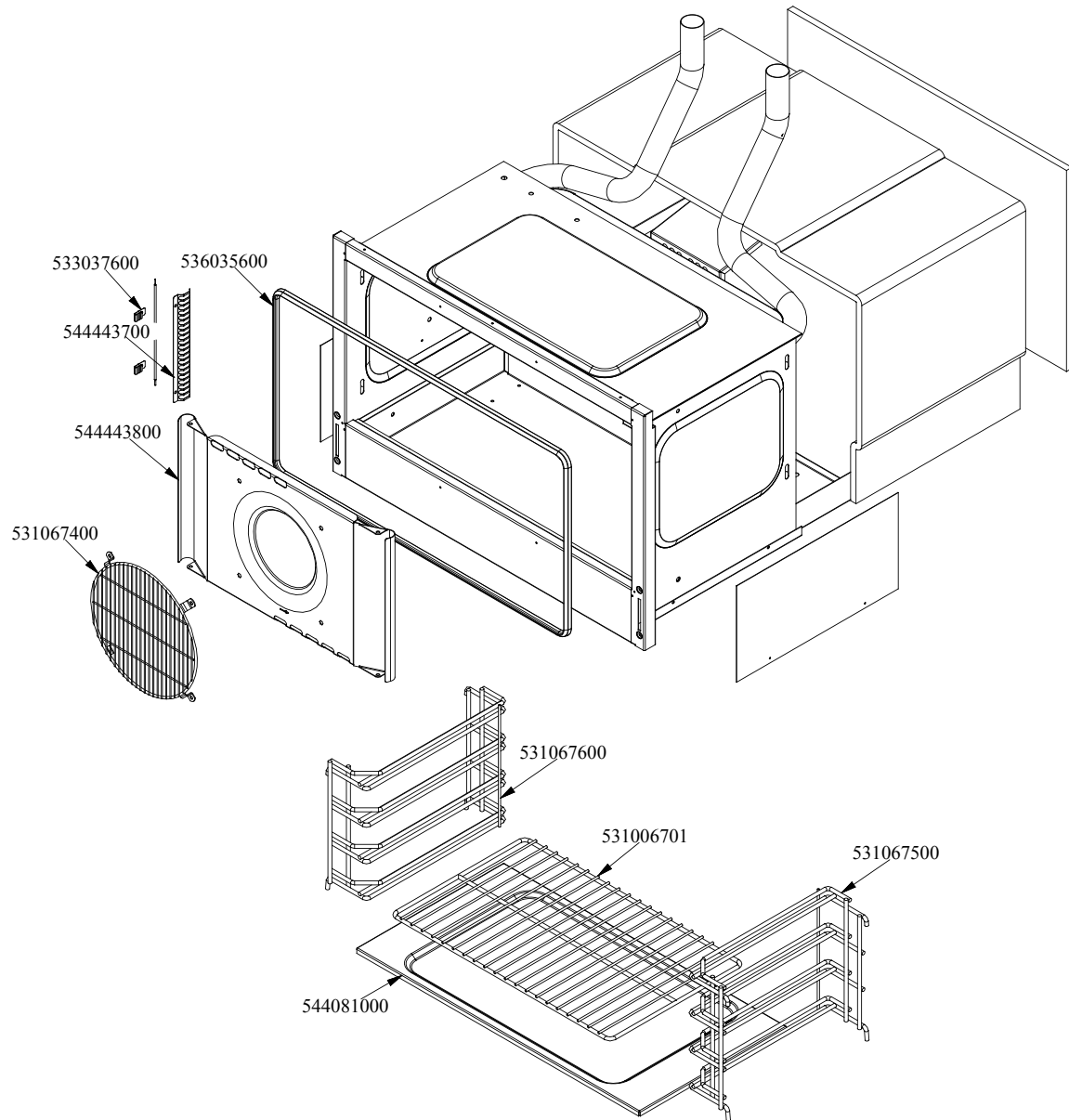

5600951 00M00P00



FORNO S70 S90 GN1/1 ELETTRICO VENTILATO CARCASSA - COMPONENTI COMUNI  
ELETTRICOVENTILATO

Codice	Descrizione
533037600	MOLLA FISS.BULB.Ø3/Ø4 PIATTA BR.
536035600	GUARNIZ.FORNO GN1/1 S70/90 VENT.
544443800	PANN.DIFF.ARIA.F.VENT.S70
531067400	GRIGLIA PROT.VENT.FORN.VENT.S70
531067600	PORTAGRIGLIA FORNO S70 SX GN1/1
531006701	GRIGLIA FORNO MAXI S60T/65/60
531067500	PORTAGRIGLIA FORNO S70 DX GN1/1
544081000	SUOLA FORNO EL.GN1/1 S55
544443700	PROTEZIONE BULBO FORNO VENTILATO



MFV-78ET (SN>=1201<=1604)  
Tav. 560095200M01P00

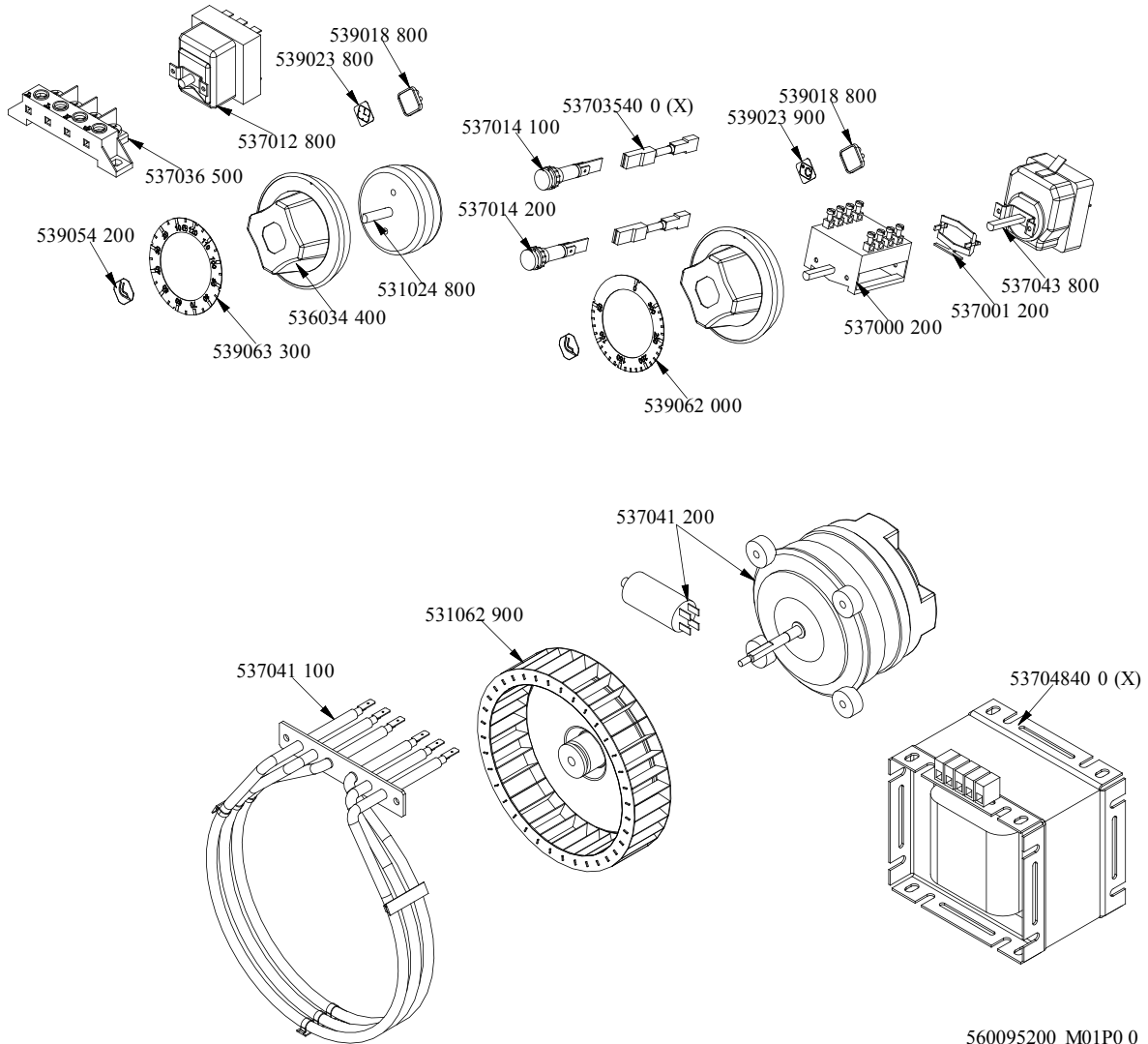

560095200 M01P0 0



## MFV-78ET (SN&gt;=1201&lt;=1604) - BASE CON FORNO ELTRICO VENTILATO MFV-78ET

Codice	Descrizione
539054200	BOLLINO Ø20,3 CR."L" LOTUS R.
537036500	MORSETT.4 POLI 40A VITE-VITE
537012800	TERMOST.SIC.TRIF. 420°C
539023800	ET.AD.IND.TYMER FORNO
539018800	INDICE MAN.C/VANO ETICHETTA
539063300	DISC.72.TYMER MECCANICO
536034400	MANOP.Ø77 4 P.Ø06X4,6 NERO C/M
531024800	TIMER MECCANICO 120'
537014200	SPIA G.B.VERDE 250VAC F.M.
537014100	SPIA G.B.BIANC.250VAC F.M.
539023900	ET.AD.IND.TEMPERATURA FORNO
539018800	INDICE MAN.C/VANO ETICHETTA
537043800	TERMOST.F.TRIF. 048-300°C GAMB.L
537001200	STAFF.FISS.COMM.S49 TERMOST.3,5
537000200	COMM.1 POS.3F 16A
539062000	DISC.72.FORN.S70 E.ST.TERM.
537041100	RES.COR.FOR.VENT 5200W 3-230V
531062900	VENTOLA Ø180 FORNO VENTIL.S70
537041200	MOTOVENT.FORNO VENT. S70 C/COND.



COMANDO E PIANO PC-E S90 (SN<=1604)  
Tav. 560023700M01C00

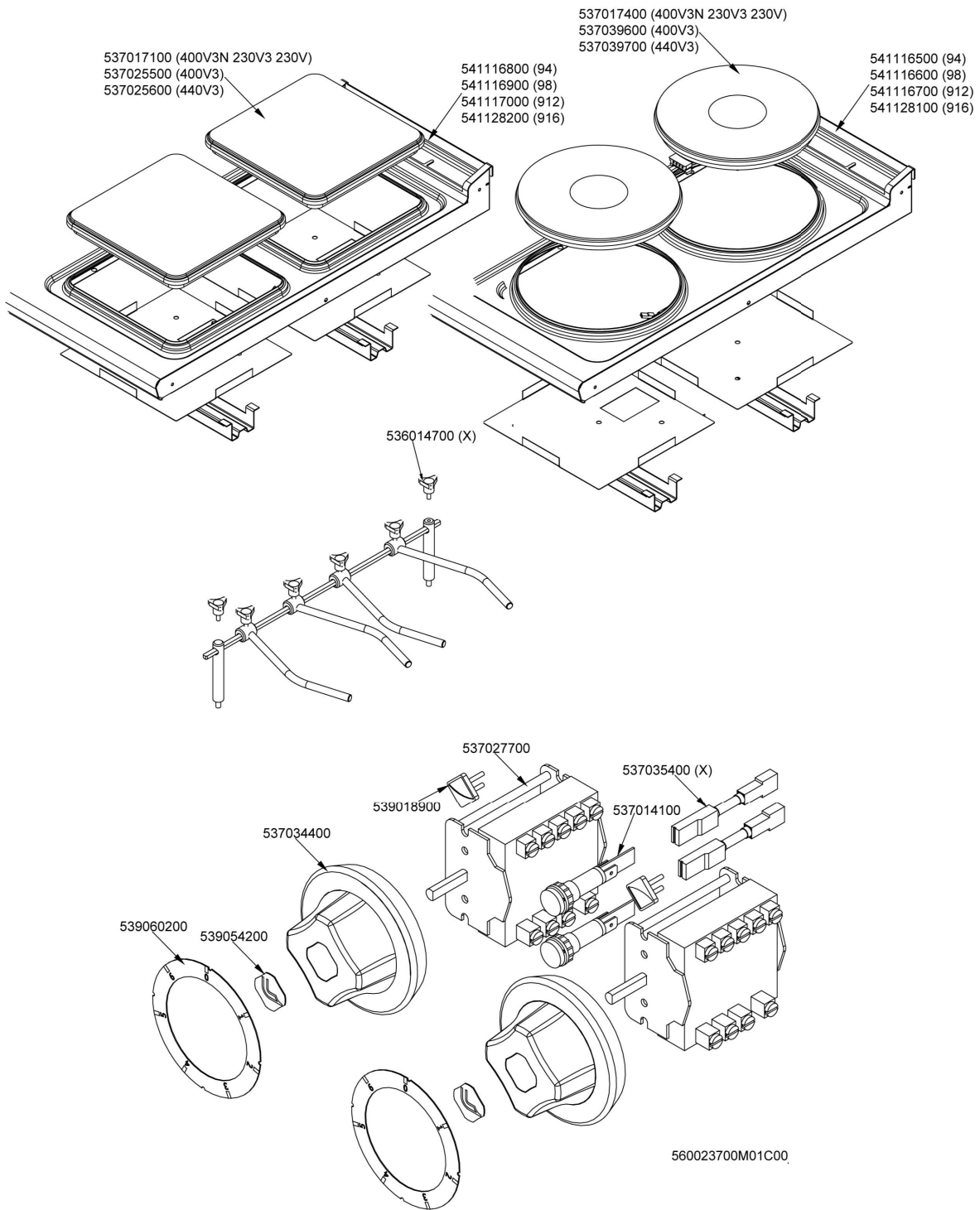



COMANDO E PIANO PC-E S90 (SN<=1604) - COMPONENTI COMUNI COMANDO\_E\_PIA  
E\_PCT-E(

Codice	Descrizione
541116500	ASS.PIANO S90 PC-94E
541116600	ASS.PIANO S90 PC-98E
541116700	ASS.PIANO S90 PC-912ET
541128100	ASS.PIANO S90 PC-916ET
537017400	PIASTRA GHISA Ø300 3500W230V
537039600	PIASTRA GHISA Ø300 3500W400V
537039700	PIASTRA GHISA Ø300 3500W440V
541116800	ASS.PIANO S90 PCQ-9 4E
541116900	ASS.PIANO S90 PCQ-9 8E
541117000	ASS.PIANO S90 PCQ-912E
541128200	ASS.PIANO S90 PCQ-916E
537017100	PIASTRA GHISA 300X300 4000W230V
537025500	PIASTRA GHISA 300X300 4000W400V
537025600	PIASTRA GHISA 300X300 4000W440V
536014700	VOLANTINO A 3 PUNTE M6X15
537035400	RES.ELETR.3W 330KOHM C/F
537014100	SPIA G.B.BIANC.250VAC F.M.
537027700	COMM.7 POS.32A PC
539018900	INDICE MAN.C/FRECCIA ROSSA
537034400	RES.IRR.470X270 9500W 3-230V (S)
539054200	BOLLINO Ø20,3 CR."L" LOTUS R.
539060200	DISC.72.7 POS.PC -E R.

COMPONENTI COMUNI PORTE APPARECCHI  
 Tav. 560012802M00P00

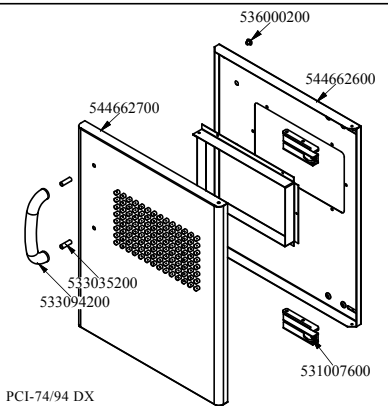
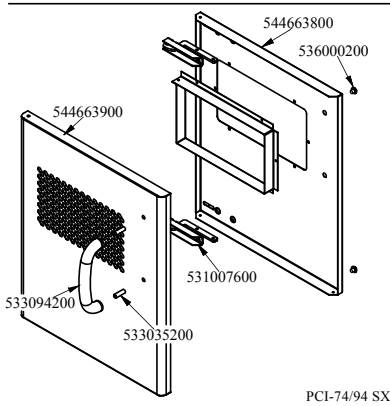
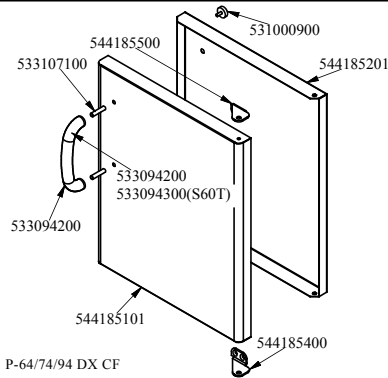
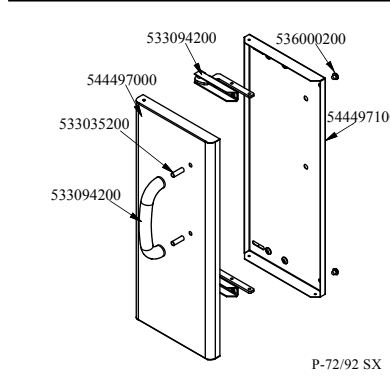
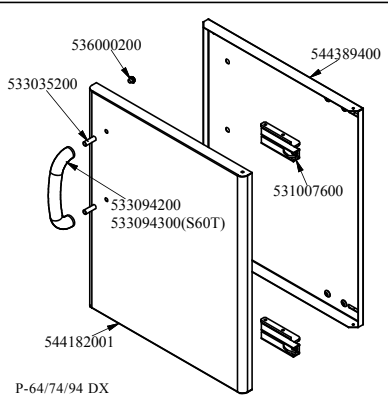
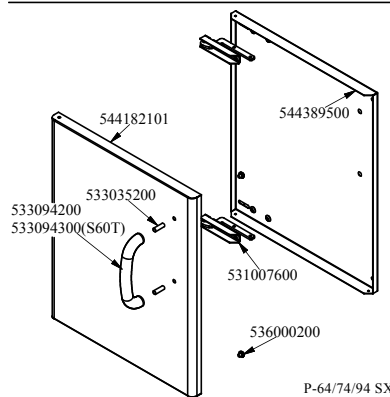
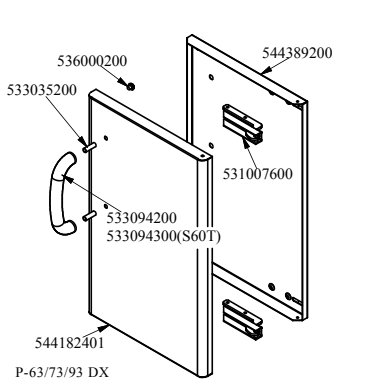
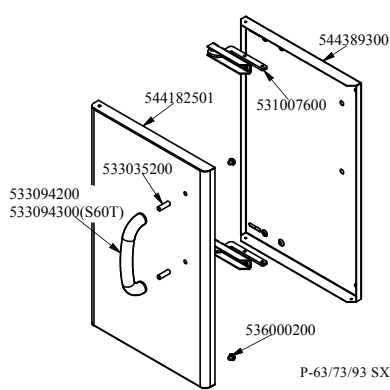



## COMPONENTI COMUNI PORTE APPARECCHI - COMPONENTI COMUNI PORTE

Codice	Descrizione
544185101	PORTA 74 CF DX
533107100	DIST.MANIGLIA S70 CF
533094200	MANIGLIA S70/90 INOX
544185400	CERNIERA PORTA MOB.CF S70 INF.
544185500	CERNIERA PORTA MOB.CF S70 SUP.
544185201	CONTROP.74 DX APP. LT CF
531000900	MAGNETE Ø22 KG.3 C/DISCH.
536000200	PARACOLPI Ø12 H.4
544182001	PORTA 74 DX
531007600	CERNIERA PORTA MOBILI
544389400	CONTROP.74 DX APP. LT
533035200	DIST.MANIGLIA S65 S70
544182101	PORTA 74 SX
544389500	CONTROP.74 SX APP. LT
544182401	PORTA 73 DX
544389200	CONTROP.73 DX APP. LT
544389300	CONTROP.73 SX APP. LT
544182501	PORTA 73 SX
544497000	PORTA 72 SX
544497100	CONTROP.72 SX APP. LT
544663900	PORTA 74 SX PCI
544663800	CONTROP.74 SX APP. LT PCI
544662700	PORTA 74 DX PCI
544662600	CONTROP.74 DX APP. LT PCI
533094300	MANIGLIA S60T INOX