

Mod. MB 9510 – MB 9510R

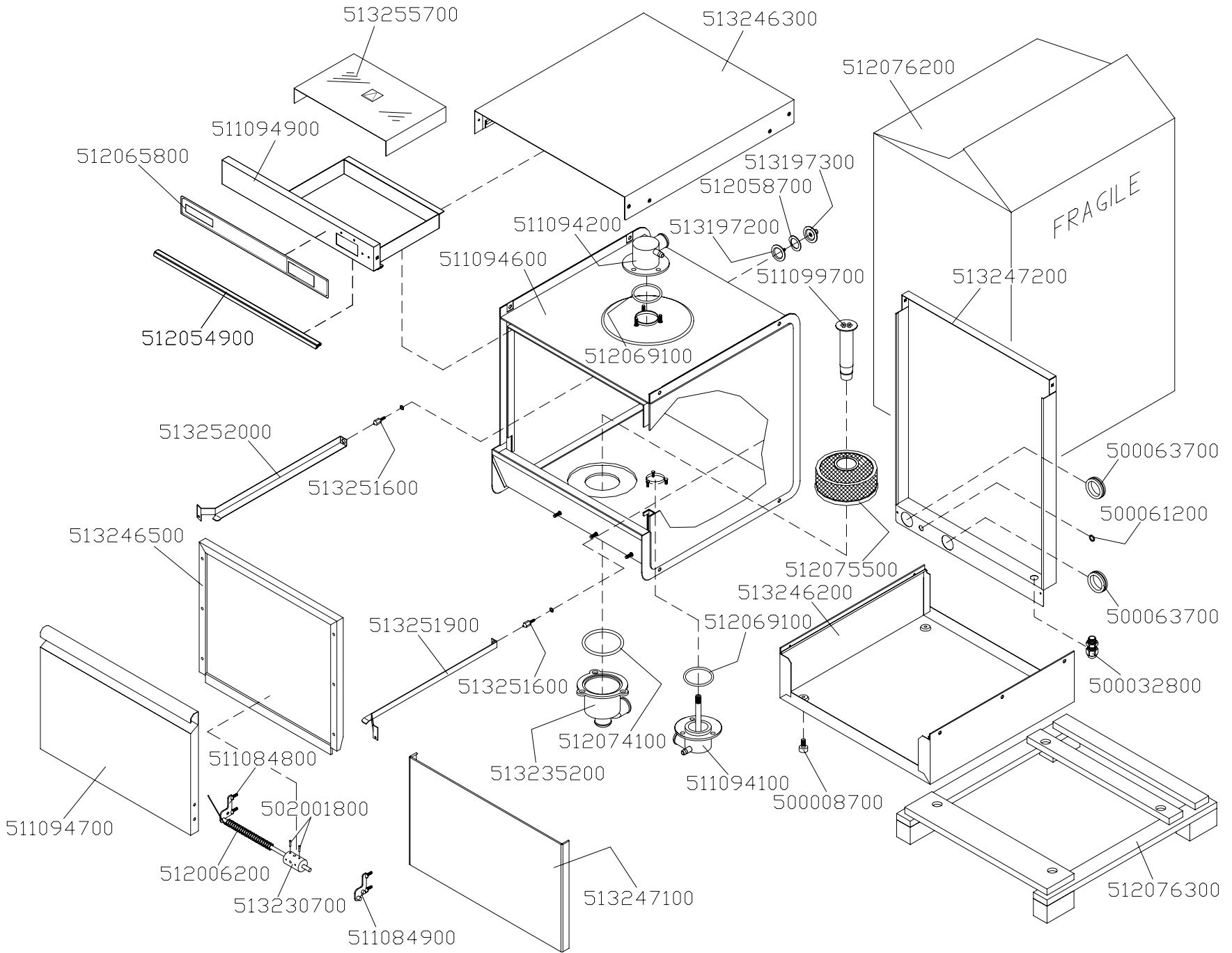

esterno/external

Mod. MS 9510 - MB 9510R

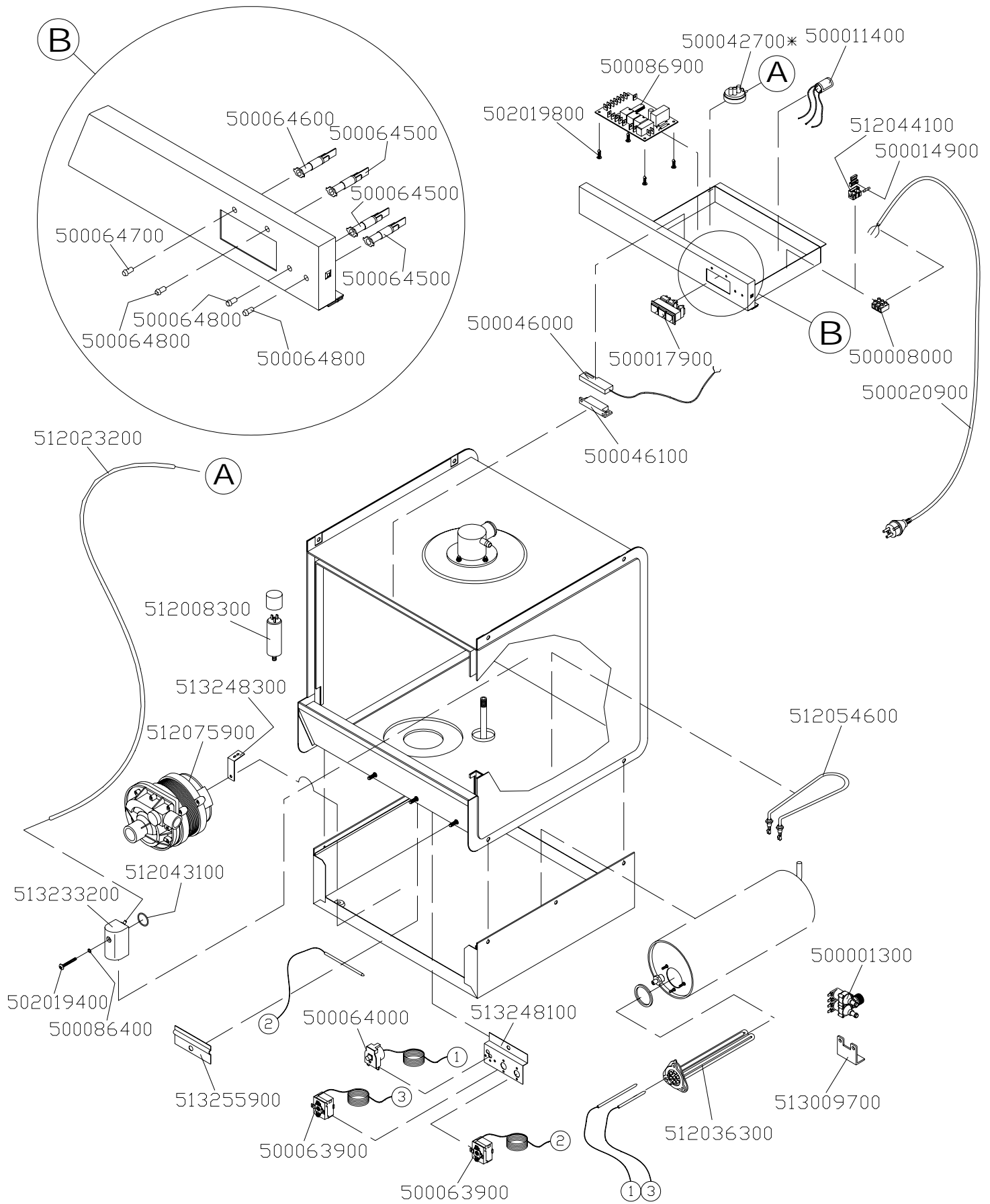

elettrico/electrical

Mod. MB 9510 – MB 9510R

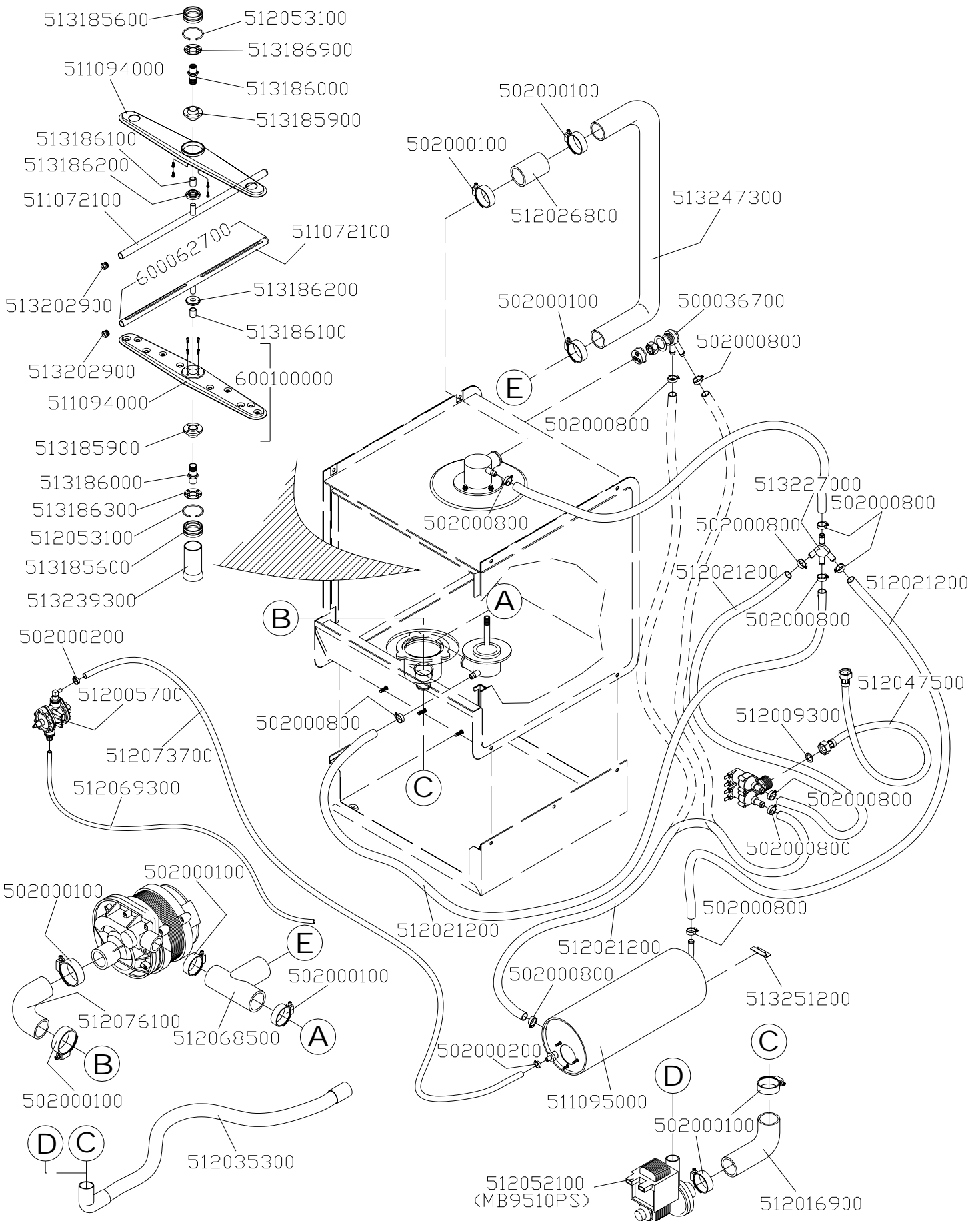

idraulico/hydraulic

POMPA HP 0,28 (cod. 512075900)

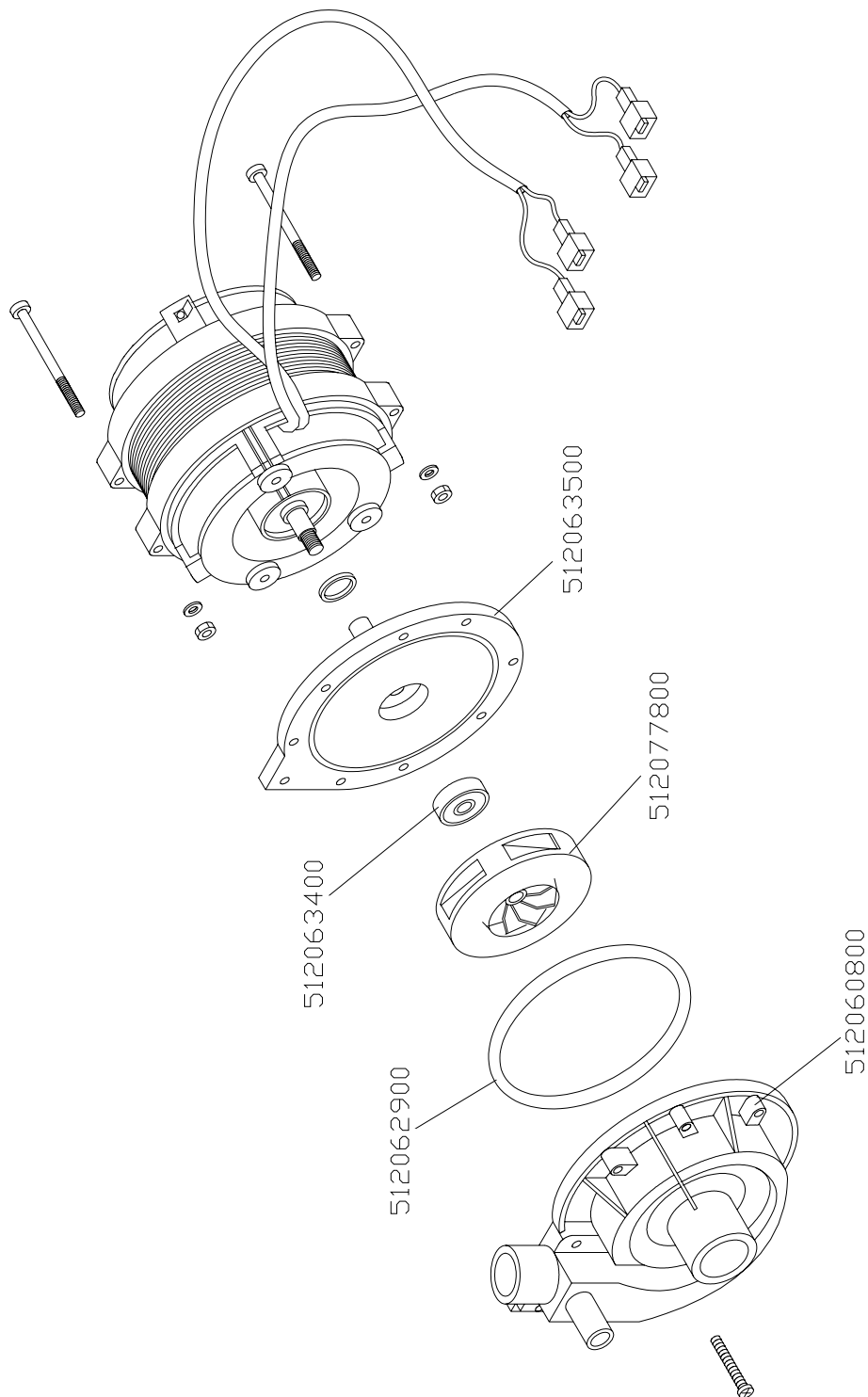

hp0,28

