

FRY-TOP ELETTRICI

Serie 900

TIPO: 9FT/E400, 9FT/E405, 9FT/E410, 9FT/E415, 9FT/E800, 9FT/E805, 9FT/E810, 94FT/E815, 9FT/E820, 9FT/E825, 9FTV/E400, 9FTV/E405, 9FTV/E410, 9FTV/E415, 9FTV/E800, 9FTV/E805, 9FTV/E810, 9FTV/E815, 9FTV/E820, 9FTV/E825

Ricambio





Parti di ricambio

ID	Tipo	Descrizione	Codici del produttore
Module: Parti esterne			
10		Piedino	826490142
20		Cassetto	2546510
35	400,400V	Piastra	826470610
	410,410V	Piastra	826470670
	405,405V	Piastra	826470710
	415,415V	Piastra	826470770
	800,800V	Piastra	826470620
	820,820V	Piastra	826470640
	810,810V	Piastra	826470680
	805,805V	Piastra	826470720
	825,825V	Piastra	826470740
	815,815V	Piastra	826470780
40		Manopola	824710250
41		Guarnizione manopola	825110510
50		Gemma verde	826650050
55		Segnalatori luminosi	6A038506
60		Gemma bianca	6A039207

400=9FT/E400, 405=9FT/E405, 410=9FT/E410, 415=9FT/E415, 800=9FT/E800, 805=9FT/E805, 810=9FT/E810, 815=9FT/E, 820=9FT/E820, 825=9FT/E825, 400V=9FTV/E400, 405V=9FTV/E405, 410V=9FTV/E410, 415V=9FTV/E415, 800V=9FTV/E800, 805V=9FTV/E805, 810V=9FTV/E810, 815V=9FTV/E815, 820V=9FTV/E820, 825V=9FTV/E825

A=3/N/PE~400/230V 50Hz, H=3/PE~230V 50Hz, P=1/N/PE~220-240V 50Hz

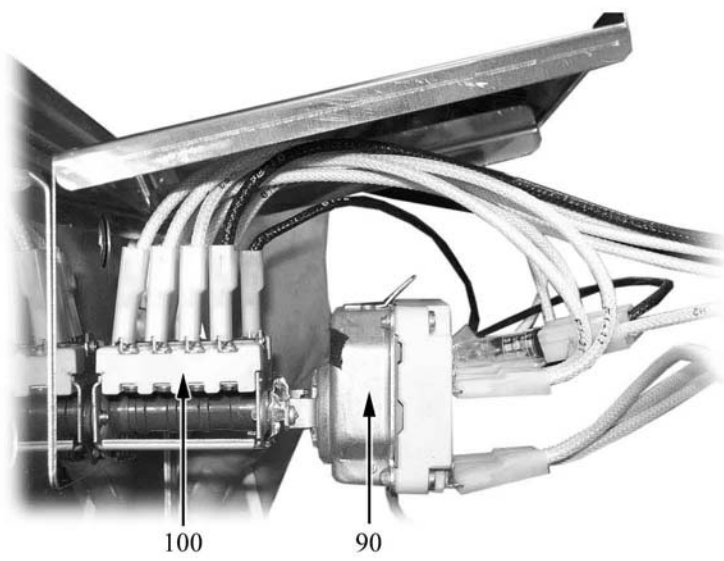
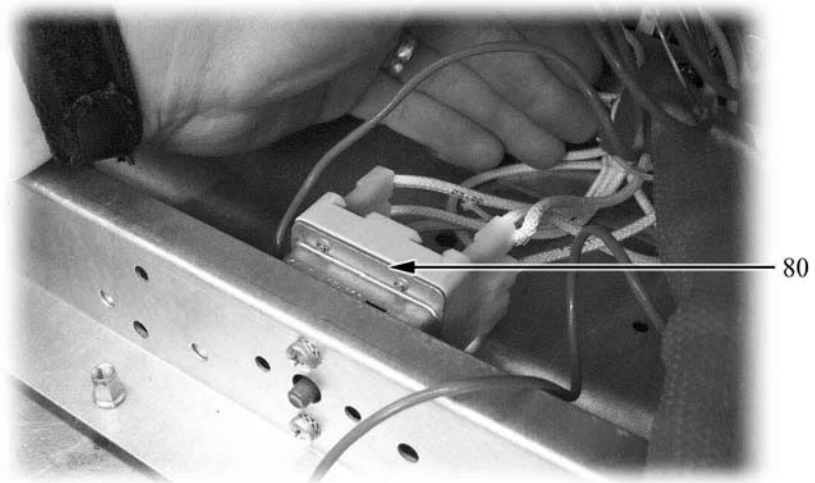
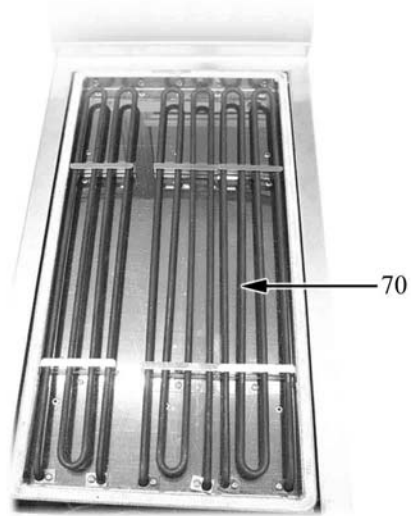

Parti di ricambio

ID	Tipo	Descrizione	Codici del produttore
Module:Componenti interni			
70		Resistenza 2666 W	826620061
80		Termostato sicurezza	826630130
90		Termostato	826630123
100		Commutatore	6A046001

400=9FT/E400, 405=9FT/E405, 410=9FT/E410, 415=9FT/E415, 800=9FT/E800, 805=9FT/E805, 810=9FT/E810, 815=9FT/E, 820=9FT/E820, 825=9FT/E825, 400V=9FTV/E400, 405V=9FTV/E405, 410V=9FTV/E410, 415V=9FTV/E415, 800V=9FTV/E800, 805V=9FTV/E805, 810V=9FTV/E810, 815V=9FTV/E815, 820V=9FTV/E820, 825V=9FTV/E825

A=3/N/PE~400/230V 50Hz, H=3/PE~230V 50Hz, P=1/N/PE~220-240V 50Hz