

SERIE 700

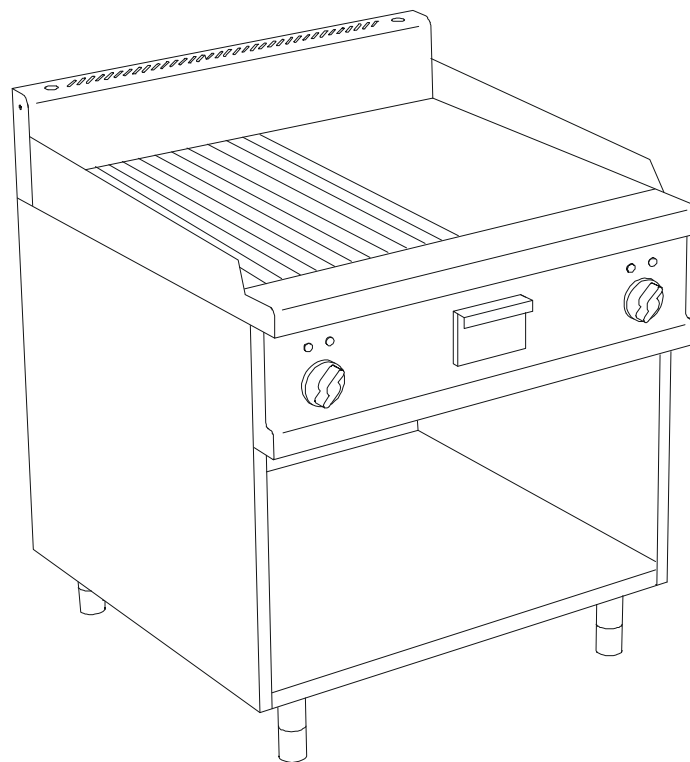

FRY-TOPS ELETTRICI, SU VANO A GIORNO, PIASTRA LISCIA - RIGATA
ELECTRIC FRY TOPS, SMOOTH AND RIBBED PLATE, ON OPEN BASE
ELEKTRO GRILLPLATTEN, BRATPLATTE GLATT - GERILLT,
SCHRANKUNTERBAU OFFEN



GRILLADES ELECTRIQUES, PLAQUE LISSE - RAINUREE, ARMOIRE OUVERTE

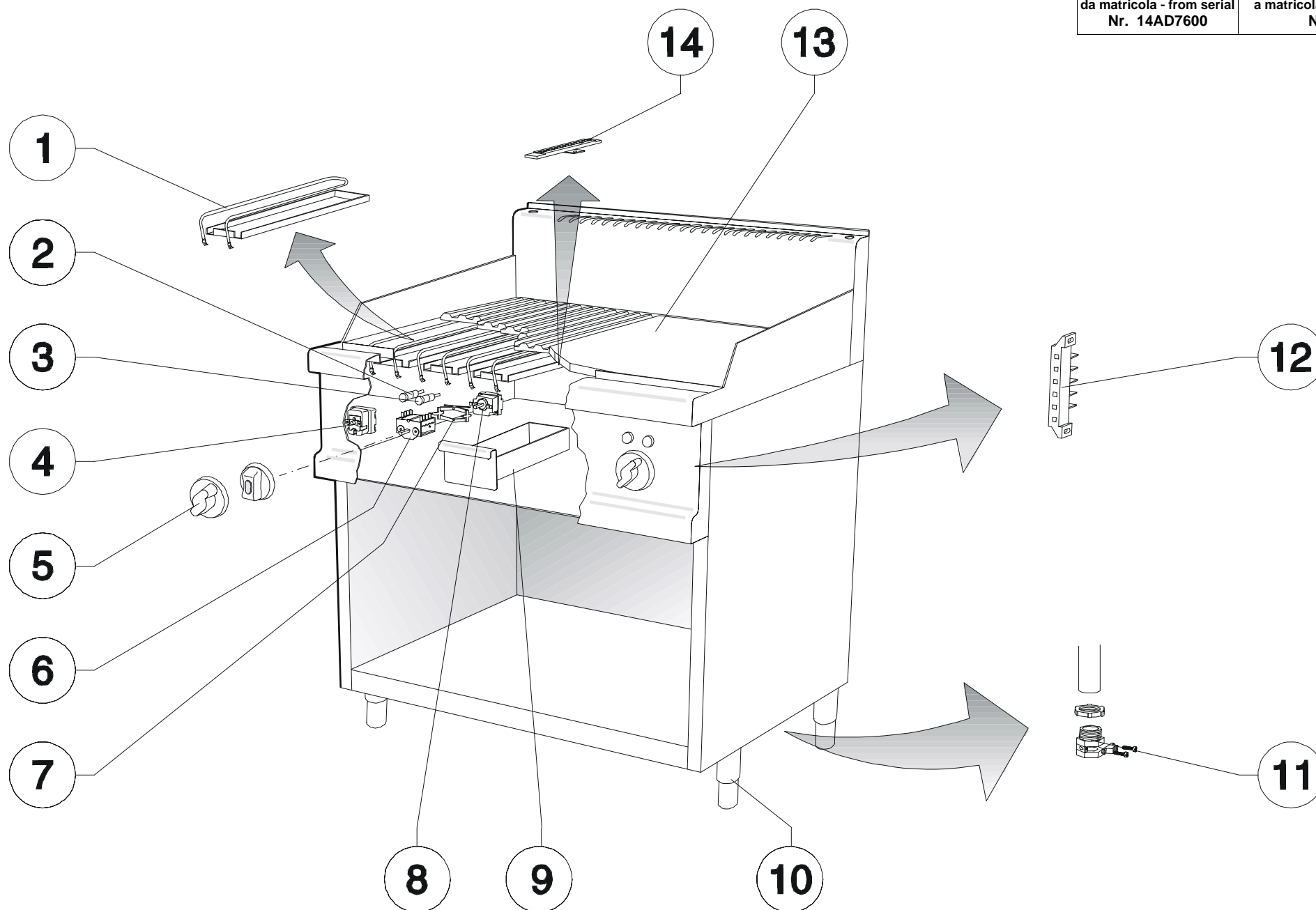

	COD.	REV.		DESCRIZIONE	DESCRIPTION	BESCHREIBUNG	DESCRIPTION
1	0109041	00	C	Resistenza 1135W - 220V (fino al 15/02/98)	Heating element 1135W - 220V (up to 15/02/98)	Heizung 1135W - 220V (bis 15/02/98)	Résistance 1135W - 220V (jusq'à 15/02/98)
1	0101563	01	C	Resistenza 1580W - 240V (dal 16/02/98)	Heating element 1580w - 240V (since 16/02/98)	Heizung 1580w - 240V (seit 16/02/98)	Résistance 1580w - 240V (depuis 16/02/98)
2	0101169		C	Lampada 380V verde	Green signal lamp 380V	Kontrolleuchte grünfarbenig 380V	Voyant vert 380V
3	0101167		C	Lampada 380V arancione	Orange signal lamp 380V	Kontrolleuchte orangefarbig 380V	Voyant orange 380V
4	0101372	00	C	Termostato di sicurezza (fino al 15/02/98)	Safety thermostat (up to 15/02/98)	Sicherheitsthermostat (bis 15/02/98)	Thermostat de sécurité (jusq'à 15/02/98)
4	0101375	01	C	Termostato di sicurezza (dal 16/02/98)	Safety thermostat (since 16/02/98)	Sicherheitsthermostat (seit 16/02/98)	Thermostat de sécurité (depuis 16/02/98)
5	0101789	00		Manopola "S" termostato 50°-310°C (fino al 15/02/98)	Thermostat knob "S" 50°-310°C (up to 15/02/98)	Thermostatknobel "S" 50°-310°C (bis 15/02/98)	Manette thermostat "S" 50°-310°C (jusq'à 15/02/98)
5	0101799	01		Manopola "S" termostato 45°-295°C (dal 16/02/98)	Thermostat knob "S" 45°-295°C (since 16/02/98)	Thermostatknobel "S" 45°-295°C (seit 16/02/98)	Manette thermostat "S" 45°-295°C (depuis 16/02/98)
5a	0101956	00		Manopola Ø65 per termostato 50°-310°C completa di tappo (fino al 15/02/98)	Thermostatknob Ø 65 50°-310°C with insert (up to 15/02/98)	Thermostatknobel Ø 65 50°-310°C mit Pfropfen (bis 15/02/98)	Manette thermostat Ø 65 50°-310°C avec insert (jusq'à 15/02/98)
5a	0101963	01		Manopola Ø65 per termostato 45°-295°C completa di tappo (dal 16/02/98)	Thermostat knob Ø 65 45°-295°C with insert (since 16/02/98)	Thermostatknobel Ø 65 45°-295°C mit Pfropfen (seit 16/02/98)	Manette thermostat Ø 65 45°-295°C avec insert (depuis 16/02/98)
6	0101398		C	Commutatore	Changeover switch	Umschalter	Commutateur
7	0101378			Staffa EGO - 817078	Bracket EGO - 817078	Stütze EGO - 817078	Etrier EGO - 817078
8	0101384	00	C	Termostato di funzionamento (fino al 15/02/98)	Thermostat (up to 15/02/98)	Thermostat (bis 15/02/98)	Thermostat de fonctionnement (jusq'à 15/02/98)
8	0101373	01	C	Termostato di funzionamento (dal 16/02/98)	Thermostat (since 16/02/98)	Thermostat (seit 16/02/98)	Thermostat de fonctionnement (depuis 16/02/98)
9	LB121-00			Assieme cassetto raccogliolio	Drawer	Schublade	Tiroir
10	0100323	02		Assieme piedino da 1" 3/4 H=165	Foot 1"3/4 H=165	Fuss 1"3/4 H=165	Pied 1"3/4 H=165
11	0101302			Pressacavo V-TEC 16C	Cable fastner V-TEC 16C	Kabelpresse V-TEC 16C	Presse-câble V-TEC 16C
11a	0101316			Dado PG16	Nut PG16	Mutter PG16	Ecrou PG16
12	0101255			Morsettiera	Junction block	Anschlußklemme	Serre-fils
13	LC530-00			Piastra liscia-rigata	Ribbed-smooth plate	Bratplatte glatt - gerillt	Plaque ½ lisse et ½ nervurée
14	LB636-00			Tassello proteggi bulbo	Bulb protection	Fühlerschutz	Protection bulb