

SERIE 1100

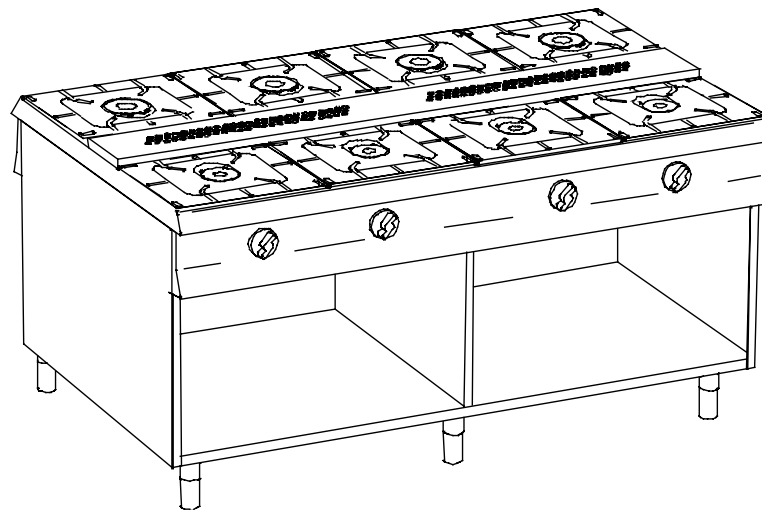

CUCINA PASSANTE GAS, 8 FUOCHI, SU VANO A GIORNO

4 bruciatori da 5.5 Kw + 4 bruciatori da 7 Kw

8 PASS THROUGH BURNERS ON OPEN BASE

4 burners 5.5 Kw + 4 burners 7 kW

8 FLAMMEN-GASHERD, UNTERBAU OFFEN DURCHGEHEND

4 x 5.5 kW-Brenner + 4 x 7 kW-Brenner

FORNEAUX GAZ 8 FEUX, ARMOIRE OUVERTE

4 brûleurs 5.5 Kw + 4 brûleurs 7 Kw

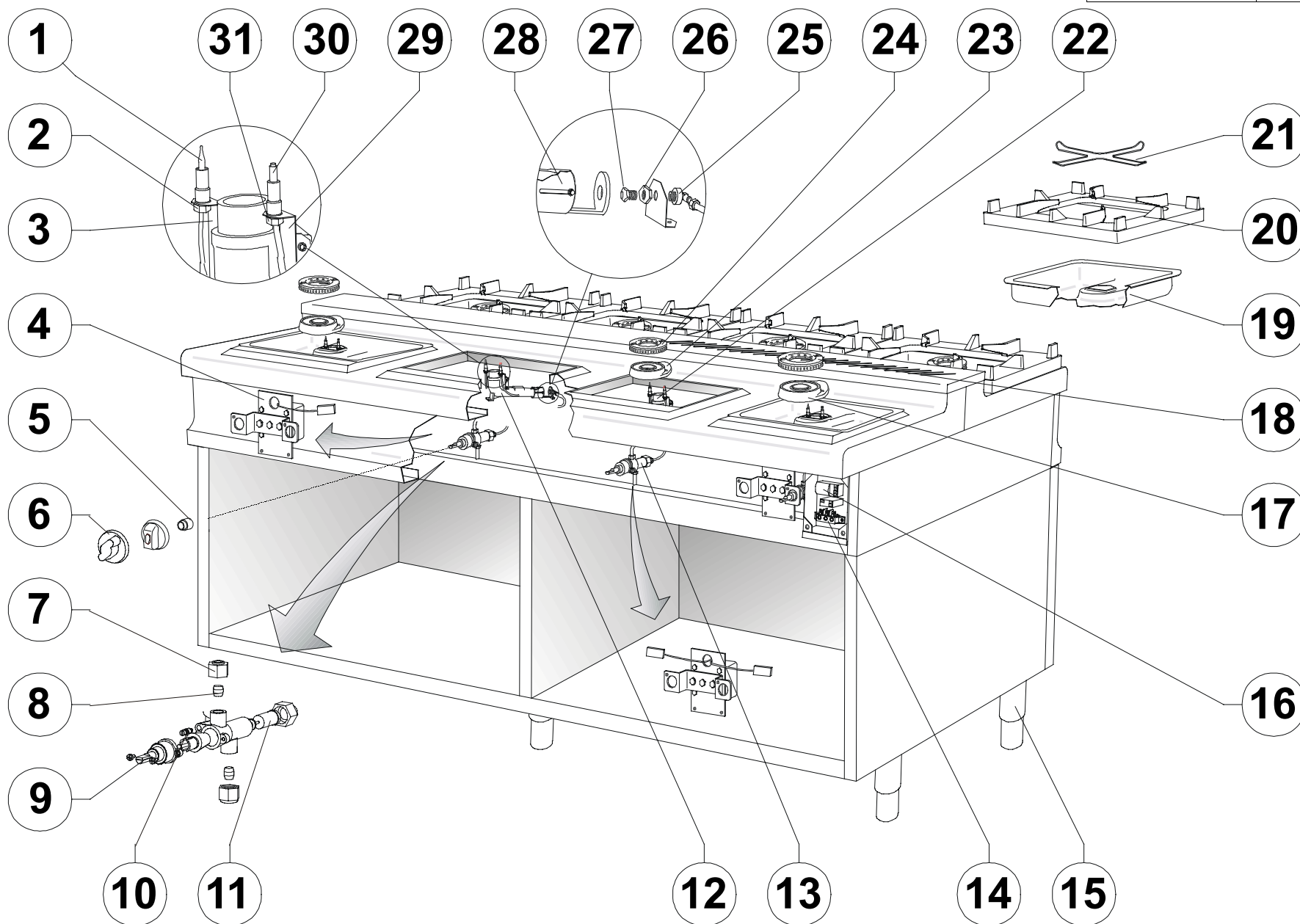

	COD.	REV.	DESCRIZIONE	DESCRIPTION	BESCHREIBUNG	DESCRIPTION
1	0100808		C Termocoppia L=400 mm	Thermocouple L=400 mm	Thermoelement 400 mm lang	Couple thermo-électrique L=400 mm
2	0100817		Raccordo fissaggio termocoppia	Thermocouple connection	Verschraubung für Thermoelement	Raccord pour couple thermo-électrique
3	LB838-00		Supporto per termocoppia	Support for thermocouple	Halterung für Thermoelement	Support couple thermo-électrique
4	9300519		Assieme gruppo accensione	Ignition unit	Zündungsgruppe	Groupe d'allumage
5	9201543		Prolunga per manopola	Extension for knob	Verlängerung für Knebel	Prolonge pour manette
6	0101786		Manopola "S" per fuochi aperti	Knob "S" for open burners	Knebel "S" für offene Kochstellenbrenner	Manette "S" pour feux vifs
6a	0101953		Manopola Ø65 per fuochi aperti completa di tappo	Knob Ø65 for open burners with insert	Knebel Ø65 für offene Kochstellenbrenner mit Pfropfen	Manette Ø65 pour feux vifs avec insert
7	0100774		Dado EU gas	Gas nut EU	Gas Mutter EU	Ecrou gaz EU
8	0100775	C	Bicono per conduttura gas Ø10	Gas pipe bush Ø10	Doppelkegelring für Gasleitung Ø10	Bicône pour tube gaz Ø10
9	0100767		Cappuccio per rubinetto gas	Cap for gas cock	Kappe für Gashahn	Chapuchon pour robinet gaz
10	(vedi tab.)		By-pass	By-pass	By-pass	By-pass
11	0100752	C	Magnete	Magneto	Magnet	Magnéto
12	0100217		Venturi per bruciatore E	Venturi tube for burner E	Venturirohr für E-Brenner	Venturi pour brûleur E
13	0100730	C	Rubinetto per fuochi aperti	Cock for open burners	Gasarmatur für offene Kochstellenbrenner	Robinet pour brûleur ouverts
14	0101253		Morsettiera 2F + terra	Junction block	Klemmkasten	Serre-fils
15	0100324		Assieme piedino da 2" H=165	Foot 2" H=165	Fuss 2" H=165	Pied 2" H=165
16	0101193		Generatore Trasn. Zig 2	Generator-transformer Zig 2	Umformer-Generator Zig 2	Generateur-Transformateur Zig 2
16a	0101195		Generatore Trasn. Zag 6	Generator-transformer Zag 6	Umformer-Generator Zag 6	Generateur-Transformateur Zag 6
17	0100216		Corpo per bruciatore E	Body for burner E	Brennerkörper E	Corps pour brûleur E
18	0100253		Spartifiamma per bruciatore E	Flame spreader for burner E	Brennerdeckel E	Couvercle pour brûleur E
19	9203250		Bacinella in acciaio inox	Stainless steel basin	Kochmulde aus Edelstahl	Plateau inox
20	9203942		Griglia piano	Pan support	Auflagerost	Grille
21	0101080		Griglia riduzione	Pan support reduction piece	Reduzierring	Grille de réduction
22	0100207		Venturi per bruciatore D	Venturi tube for burner D	Venturirohr für D-Brenner	Venturi pour brûleur D
23	0100209		Corpo per bruciatore D	Body for burner D	Brennerkörper D	Corps pour brûleur D
24	0100251		Spartifiamma per bruciatore D	Flame spreader for burner D	Brennerdeckel D	Couvercle pour brûleur D
25	0100767		Raccordo per ugello	Nozzle junction	Düsenverbindung	Raccord gicleur
26	0100770		Dado	Nut	Mutter	Ecrou
27	(vedi tab.)		Ugello	Nozzle	Düse	Gicleur
28	0100264		Boccola aria primaria	Primary air bush	Luftschieber	Douille air primaire
29	LB839-00		Supporto per candela d'accensione	Support for igniter plug	Gakterybg für Zündkerze	Support pour bougie d'allumage
30	9300539	C	Candela e cavetto d'accensione L=1750 mm	Igniter plug and cable L=1750 mm	Zündkerze mit Zündkabel 1750 mm lang	Bougie et fil d'allumage L=1750 mm
30a	9300540	C	Candela e cavetto d'accensione L=1350 mm	Igniter plug and cable L=1350 mm	Zündkerze mit Zündkabel 1350 mm lang	Bougie et fil d'allumage L=1350 mm
30b	9300541	C	Candela e cavetto d'accensione L=950 mm	Igniter plug and cable L=950 mm	Zündkerze mit Zündkabel 950 mm lang	Bougie et fil d'allumage L=950 mm
30c	9300542	C	Candela e cavetto d'accensione L=550 mm	Igniter plug and cable L=550 mm	Zündkerze mit Zündkabel 550 mm lang	Bougie et fil d'allumage L=550 mm
31	0100620		Raccordo per candela d'accensione	Igniter plug connection	Verschraubung für Zündkerze	Raccord pour bougie d'allumage

TIPO DI BRUCIATORE	GAS	NAZIONI EN 203 - 1	PRESSIONE DI ALIMENTAZIONE	COD. UGELLO Pos. 27	Ø 1/100	COD. BY-PASS Pos. 10	Ø 1/100
5.5Kw	G 20	AT-DK-ES-FI-IE-IT-PT-GB-SE-CH-GR	20 mbar	0102012	180	0102061	110
		DE-BE-FR-LU	20/25 mbar	0102012	180	0102061	110
	G 25	NL	25 mbar	0100906	185	0102066	115
		DE	20 mbar	0101020	200	0102065	120
	G 30 G 31	BE-DK-ES-FI-FR-IE-GR IT-NL-PT-GB-SE-NO-LU	28-30/37 mbar	0100907	116	0102067	70
		DE-AT-CH	50 mbar	0102013	95R	0102063	60
G 110	ES-DK-IT-SE-CH	8 mbar	0102044	350	REGOLABILE	-	
7Kw	G 20	AT-DK-ES-FI-IE-IT-PT-GB-SE-CH-GR	20 mbar	0101020	200	0102065	120
		DE-BE-FR-LU	20/25 mbar	0101020	200	0102065	120
	G 25	NL	25 mbar	0102015	207	0102068	130
		DE	20 mbar	0102014	220	0102068	135
	G 30 G 31	BE-DK-ES-FI-FR-IE-GR IT-NL-PT-GB-SE-NO-LU	28-30/37 mbar	0101019	130	0102087	85
		DE-AT-CH	50 mbar	0102016	105R	0102067	70
G 110	ES-DK-IT-SE-CH	8 mbar	0102045	420	REGOLABILE	-	



COD. XES30101/H

PAG. 5/5