

SERIE 700

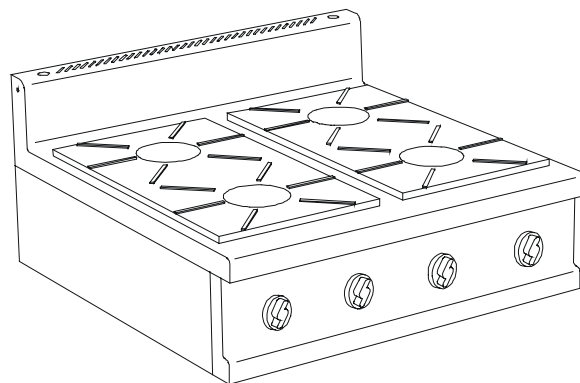

CUCINA GAS 4 FUOCHI, A SBALZO

2 bruciatori da 3.5 Kw + 2 bruciatori da 5.5 Kw

GAS RANGES 4 BURNERS

2 burners 3.5 Kw + 2 burners 5.5 kW

GASHERDE 4 FLAMMEN

2 x 3.5kW-Brenner + 2 x 5.5 kW-Brenner

FORNEAUX GAZ 4 FEUX

2 brûleurs 3.5 Kw + 2 brûleurs 5.5 Kw

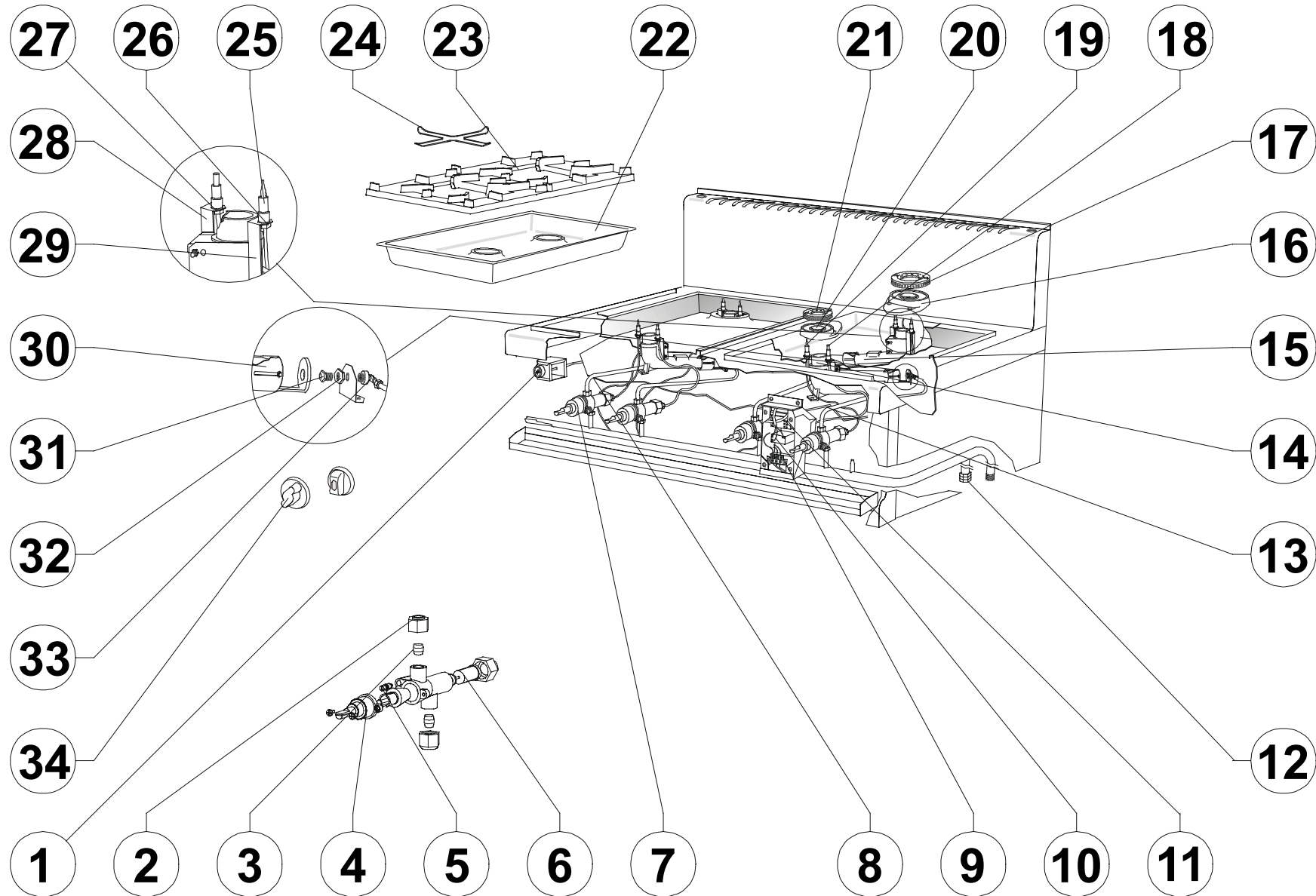

	COD.	REV.	DESCRIZIONE	DESCRIPTION	BESCHREIBUNG	DESCRIPTION
1	0101188		C Pulsante per accensione elettrica	Electric ignition key	Druckknopf für el. Zündung	Bouton d'allumage électrique
2	0100774		Raccordo per condotta gas Ø10	Gas pipe fitting Ø10	Verschraubung für Gasleitung Ø10	Raccord pour tube gaz Ø10
3	0100775		Bicono per condotta gas Ø10	Gas pipe bicone Ø10	Doppelkegelring für Gasleitung Ø10	Bicône pour tube gaz Ø10
4	0100753		Cappuccio per rubinetto	Cap for gas cock	Kappe für Gashahn	Copuchon pour robinet gaz
5	vedi tabella		By-pass	By-pass	By-pass	By-pass
6	0100752		Magnete	Magneto	Magnet	Magnéto
7	0100730		C Rubinetto per fuochi aperti	Cock for open burners	Gasarmatur für offene Kochstellenbrenner	Robinet pour brûleur ouverts
8	LB547-00		Conduttura gas posteriore, bruciatore D, per versione 70	Rear gas pipe burner D, version 70	Gasleitung hinten, D-Brenner, Version 70	Tube gaz arrière brûleur D, version 70
8a	LC671-00		Conduttura bruciatore 5.5 Kw posteriore, per versione 72	5.5 Kw rear gas pipe burner, version 72	5.5 Kw Gasleitung hinten, Brenner, Version 72	5.5 Kw tube gaz arrière brûleur, version 72
9	0101253		Morsettiera	Junction block	Klemmkasten	Serre-fils
10	0101193		C Trasformatore d'accensione per 2 fuochi	Ignition transformer for 2 burners	Zündtransformator für 2 brenner	Transformateur d'allumage pour 2 brûleur
12	0101275		Raccordo filettato antistr. 107Z/11	Threaded connection	Verschraubung	Raccord fileté
11	0101194		C Trasformatore d'accensione per 4 fuochi	Ignition transformer for 4 burners	Zündtransformator für 4 brenner	Transformateur d'allumage pour 4 brûleur
13	LB545-00		Conduttura gas posteriore, bruciatore C, per versione 70	Rear gas pipe burner C, version 70	Gasleitung hinten, C-Brenner, Version 70	Tube gaz arrière brûleur C, version 70
13a	LC670-00		Conduttura bruciatore 3.5 Kw posteriore, per versione 72	3.5 Kw rear gas pipe burner, version 72	3.5 Kw Gasleitung hinten, Brenner, Version 72	3.5 Kw tube gaz arrière brûleur, version 72
14	0100301		Venturi per bruciatore 3.5 kW lav. per boccola	Venturi tube for burner 3.5 kW for bush	Venturirohr für Brenner 3.5 kW für Luftschieber	Venturi pour brûleur 3.5 kW pour douille
15	0100302		Venturi per bruciatore 5.5 kW lav. per boccola	Venturi tube for burner 5.5 kW for bush	Venturirohr für Brenner 5.5 kW für Luftschieber	Venturi pour brûleur 5.5 kW pour douille
16	0100299		Corpo per bruciatore 5.5 kW con boccola	Body for burner 5.5 kW with bush	Brennerkörper 5.5 kW mit Luftschieber	Corps pour brûleur 5.5 kW avec douille
17	0100251		Spartifiamma per bruciatore D	Flame spreader r for burner D	Brennerdeckel D	Couvercle pour brûleur D
18	9300542		C Candela e cavetto d'accensione L=550 mm	Igniter plug and cable L=550 mm	Zündkerze mit Zündkabel 550 mm lang	Bougie et fil d'allumage L=550 mm
19	0100808		C Termocoppia L=400 mm	Thermocouple L=400 mm	Thermoelement 400 mm lang	Couple thermo-électrique L=400 mm
20	0100298		Corpo per bruciatore 3.5 kW con boccola	Body for burner 3.5 kW with bush	Brennerkörper 3.5 kW mit Luftschieber	Corps pour brûleur 3.5 kW avec douille
21	0100252		Spartifiamma per bruciatore C	Flame spreader for burner C	Brennerdeckel C	Couvercle pour brûleur C
22	LB847-00	01	Bacinella piano in acciaio inossidabile	Stainless steel top basin	Kochmulde aus Edelstahl	Plateau Inox
23	0101808		Griglia piano smaltata	Enamelled pan support	Auflagerost emailiert	Grille émaillée
23a	0101807		Griglia piano vetrificata	Glazed pan support	Auflagerost verglast	Grille vitrifié
24	0101080		Griglia riduzione N.S. Snack	Pan support reduction piece	Reduzierring Snack 650	Grille de réduction Snack
25	0100809		C Termocoppia L=850 mm	Thermocouple L=850 mm	Thermoelement 850 mm lang	Thermocouple L=850 mm
26	0100817		Raccordo per termocoppia	Thermocouple connection	Verschraubung für Thermoelement	Raccord pour couple thermo-électrique
27	0100620		Raccordo per candela d'accensione	Igniter plug connection	Verschraubung für Zündkerze	Raccord pour bougie d'allumage
28	LB839-00		Supporto per candela d'accensione	Support for igniter plug	Zündkerzhalter	Support pour bougie d'allumage
29	LB838-00		Supporto per termocoppia	Support for thermocouple	Halterung für Thermoelement	Support couple thermo-électrique
30	0100264		Boccola aria primaria	Primary air bush	Luftschieber	Douille air primaire
31	vedi tabella		Ugello	Nozzle	Düse	Gicleur
32	0100770		Dado	Nut	Mutter	Ecrou
33	0100767		Raccordo per ugello	Nozzle junction	Düsenverbindung	Raccord gicleur
34	0101786		Manopola "S" per fuochi aperti	Knob "S" for open burners	Knebel "S" für offene Kochstellenbrenner	Manette "S" pour feux vifs
34a	0101953		Manopola Ø65 per fuochi aperti completa di tappo	Knob Ø65 for open burners with insert	Knebel Ø65 für offene Kochstellenbrenner mit Pfropfen	Manette Ø65 pour feux vifs avec insert

TIPO DI BRUCIATORE	GAS	NAZIONI CE EN 203 - 1	PRESSIONE DI ALIMENTAZIONE	COD. UGELLO Pos. 31	Ø 1/100	COD. BY-PASS Pos. 5	Ø 1/100
C Qn = 3,5 kW	G 20	AT-DK-ES-FI-IE-IT-PT-GB-SE-CH	20 mbar	0100905	145	0102060	100
		DE-BE-FR	20/25 mbar	0100905	145	0102060	100
	G 25	NL	25 mbar	0102009	146	0102062	105
		DE	20 mbar	0109072	155	0102061	110
	G 30 G 31	BE-DK-ES-FI-FR-IE IT-NL-PT-GB-SE	28-30/37 mbar	0102010	90	0102063	60
		DE-AT-CH	50 mbar	0102011	80 R	0102064	50
D Qn = 5,5 kW	G 20	AT-DK-ES-FI-IE-IT-PT-GB-SE-CH	20 mbar	0102012	180	0102061	110
		DE-BE-FR	20/25 mbar	0102012	180	0102061	110
	G 25	NL	25 mbar	0100906	185	0102066	115
		DE	20 mbar	0101020	200	0102065	120
	G 30 G 31	BE-DK-ES-FI-FR-IE IT-NL-PT-GB-SE	28-30/37 mbar	0100907	116	0102067	70
		DE-AT-CH	50 mbar	0102013	95 R	0102063	60



COD. XES30701/D

PAG. 5/5