

SERIE 700

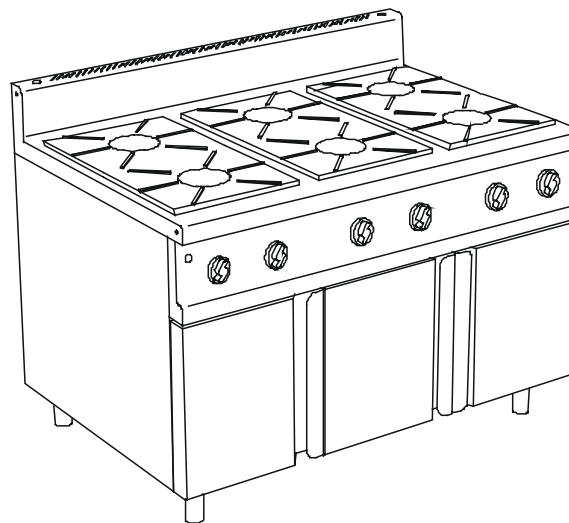

CUCINA GAS 6 FUOCHI, SU VANO ARMADIATO

4 bruciatori da 3.5 Kw + 2 bruciatori da 5.5 Kw

GAS RANGES 6 BURNERS ON CUPBOARD

4 burners 3.5 Kw + 2 burners 5.5 kW

GASHERDE 6 FLAMMEN, SCHRANKUNTERBAU MIT TÜR

4 x 3.5 kW-Brenner + 2 x 5.5 kW-Brenner

FORNEAUX GAZ 6 FEUX, ARMOIRE AVEC PORTE

4 brûleurs 3.5 Kw + 2 brûleurs 5.5 Kw

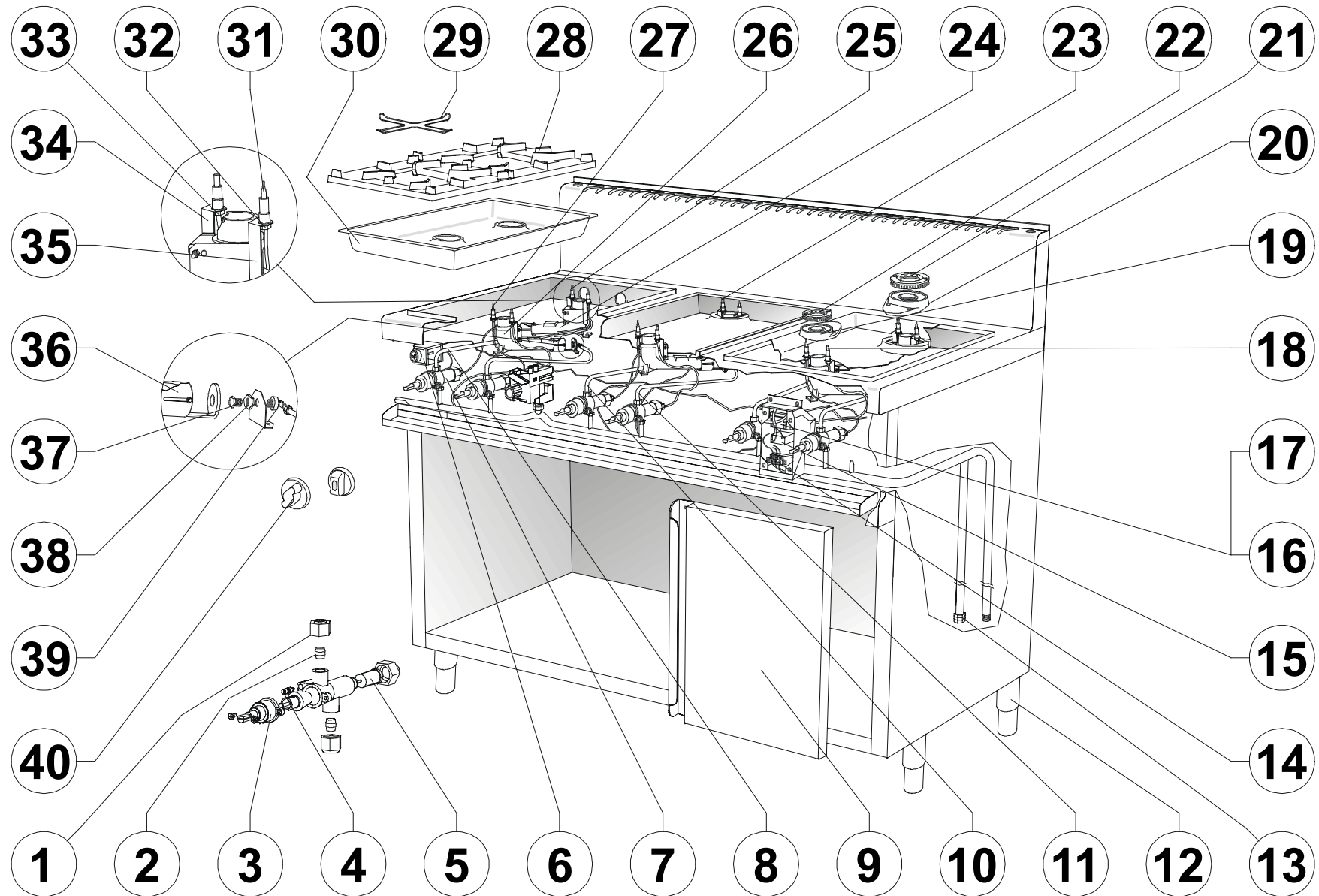

	COD.	REV.	DESCRIZIONE	DESCRIPTION	BESCHREIBUNG	DESCRIPTION
1	0100774		Raccordo per conduttura gas Ø10	Gas pipe fitting Ø10	Verschraubung für Gasleitung Ø10	Raccord pour tube gaz Ø10
2	0100775		Bicono per conduttura gas Ø10	Gas pipe bicone Ø10	Doppelkegelring für Gasleitung Ø10	Bicône pour tube gaz Ø10
3	0100753		Cappuccio per rubinetto	Cap for gas cock	Kappe für Gashahn	Copuchon pour robinet gaz
4	vedi tabella		By-pass	By-pass	By-pass	By-pass
5	0100752		Magnete	Magneto	Magnet	Magnéto
6	0101188	C	Pulsante per accensione elettrica	Electric ignition key	Druckknopf für el. Zündung	Bouton d'allumage électrique
7	0100730	C	Rubinetto per fuochi aperti	Cock for open burners	Gasarmatur für offene Kochstellenbrenner	Robinet pour brûleur ouverts
8	LB547-00		Conduttura gas posteriore, bruciatore D, per versione 70	Rear gas pipe burner D, version 70	Gasleitung hinten, D-Brenner, Version 70	Tube gaz arrière brûleur D, version 70
8a	LC671-00		Conduttura bruciatore 5.5 Kw posteriore, per versione 72	5.5 Kw rear gas pipe burner, version 72	5.5 Kw Gasleitung hinten, Brenner, Version 72	5.5 Kw tube gaz arrière brûleur, version 72
9	LB385-00		Assieme portina	Cabinet door	Schranktür	Porte armoire
9a	LB968-00		Assieme portina armadio cucine versione "1"-2	Cabinet door for ranges version 1 –2	Schranktür für Herde Ausführung 1 – 2	Porte armoire pour fourneaux version 1-2
9b	LC744-00		Assieme portina armadio cucine versione "3"	Cabinet door for ranges version 3	Schranktür für Herde Ausführung 3	Porte armoire pour fourneaux version 3
9c	LC741-00		Assieme maniglia portina armadio cucine versione "3"	Cabinet door handle version 3	Schranktürgriff Ausführung 3	Poignée porte armoire four version 3
10	LB545-00		Conduttura gas posteriore, bruciatore C, per versione 70	Rear gas pipe burner C, version 70	Gasleitung hinten, C-Brenner, Version 70	Tube gaz arrière brûleur C, version 70
10a	LC670-00		Conduttura bruciatore 3.5 Kw posteriore, per versione 72	3.5 Kw rear gas pipe burner, version 72	3.5 Kw Gasleitung hinten, Brenner, Version 72	3.5 Kw tube gaz arrière brûleur, version 72
11	LB544-00		Conduttura gas anteriore, bruciatore C, per versione 70	Front gas pipe burner C, version 70	Gasleitung vorne, C-Brenner, Version 70	Tube gaz avant brûleur C, version 70
11a	LC672-00		Conduttura bruciatore 3.5 Kw anteriore, per versione 72	3.5 Kw front gas pipe burner, version 72	3.5 Kw Gasleitung vorne, Brenner, Version 72	3.5 Kw tube gaz avant brûleur, version 72
12	0100323	02	Assieme piedino da 1"3/4 H=165	Foot 1" 3/4 H = 165	Fuss 1" 3/4 H= 165	Pied 1" 3/4 H = 165
13	0101275		Raccordo filettato antistr. 107Z/11	Threaded connection	Verschraubung	Raccord fileté
14	0101253		Morsettiere	Junction block	Klemmkasten	Serre-fils
15	0101193	C	Trasformatore d'accensione per 2 fuochi	Ignition transformer for 2 burners	Zündtransformator für 2 brenner	Transformateur d'allumage pour 2 brûleur
16	0101194	C	Trasformatore d'accensione per 4 fuochi	Ignition transformer for 4 burners	Zündtransformator für 4 brenner	Transformateur d'allumage pour 4 brûleur
17	0101195	C	Trasformatore d'accensione per 6 fuochi	Ignition transformer for 6 burners	Zündtransformator für 6 brenner	Transformateur d'allumage pour 6 brûleur
18	9300542	C	Candela e cavetto d'accensione L=550 mm	Igniter plug and cable L=550 mm	Zündkerze mit Zündkabel 550 mm lang	Bougie et fil d'allumage L=550 mm
19	0100298		Corpo per bruciatore 3.5 kW con boccola	Body for burner 3.5 kW with bush	Brennerkörper 3.5 kW mit Luftschieber	Corps pour brûleur 3.5 KW avec douille
20	0100299		Corpo per bruciatore 5.5 kW con boccola	Body for burner 5.5 kW with bush	Brennerkörper 5.5 kW mit Luftschieber	Corps pour brûleur 5.5 KW avec douille
21	0100251		Spartifiamma per bruciatore D	Flame spreader r for burner D	Brennerdeckel D	Couvercle pour brûleur D
22	0100252		Spartifiamma per bruciatore C	Flame spreader for burner C	Brennerdeckel C	Couvercle pour brûleur C
23	9300541	C	Candela e cavetto d'accensione L = 950 mm	Igniter plug and cable L=950 mm	Zündkerze mit Zündkabel 950 mm lang	Bougie et fil d'allumage L=950 mm
24	0100302		Venturi per bruciatore 5.5 kW lav. per boccola	Venturi tube for burner 5.5 kW for bush	Venturirohr für Brenner 5.5 kW für Luftschieber	Venturi pour brûleur 5.5 kW pour douille
25	9300540	C	Candela e cavetto d'accensione L=1350mm	Igniter plug and cable L=1350 mm	Zündkerze mit Zündkabel 1350 mm lang	Bougie et fil d'allumage L=1350 mm
26	0100301		Venturi per bruciatore 3.5 kW lav. per boccola	Venturi tube for burner 3.5 kW for bush	Venturirohr für Brenner 3.5 kW für Luftschieber	Venturi pour brûleur 3.5 kW pour douille
27	0100808	C	Termocoppia L=400 mm	Thermocouple L=400 mm	Thermoelement 400 mm lang	Couple thermo-électrique L=400 mm
28	0101808		Griglia piano smaltata	Enamelled pan support	Auflagerost emailliert	Grille émaillée
28a	0101807		Griglia piano vetrificata	Glazed pan support	Auflagerost verglast	Grille vitrifié
29	0101080		Griglia riduzione N.S. Snack	Pan support reduction piece	Reduzierring Snack 650	Grille de réduction Snack
30	LB847-00	01	Bacinella piano in acciaio inossidabile	Stainless steel top basin	Kochmulde aus Edelstahl	Plateau Inox
31	0100809	C	Termocoppia L=850 mm	Thermocouple L=850 mm	Thermoelement 850 mm lang	Thermocouple L=850 mm

	COD.	REV.	DESCRIZIONE	DESCRIPTION	BESCHREIBUNG	DESCRIPTION
32	0100817		Raccordo per termocoppia	Thermocouple connection	Verschraubung für Thermoelement	Raccord pour couple thermo-électrique
33	0100620		Raccordo per candela d'accensione	Igniter plug connection	Verschraubung für Zündkerze	Raccord pour bougie d'allumage
34	LB839-00		Supporto per candela d'accensione	Support for igniter plug	Zündkerzehalter	Support pour bougie d'allumage
35	LB838-00		Supporto per termocoppia	Support for thermocouple	Halterung für Thermoelement	Support couple thermo-électrique
36	0100264		Boccola aria primaria	Primary air bush	Luftschieber	Douille air primaire
37	vedi tabella		Ugello	Nozzle	Düse	Gicleur
38	0100770		Dado	Nut	Mutter	Ecrou
39	0100767		Raccordo per ugello	Nozzle junction	Düsenverbindung	Raccord gicleur
40	0101786		Manopola "S" per fuochi aperti	Knob "S" for open burners	Knebel "S" für offene Kochstellenbrenner	Manette "S" pour feux vifs
40a	0101953		Manopola Ø65 per fuochi aperti completa di tappo	Knob Ø65 for open burners with insert	Knebel Ø65 für offene Kochstellenbrenner mit Pfropfen	Manette Ø65 pour feux vifs avec insert

TIPO DI BRUCIATORE	GAS	NAZIONI CE EN 203 - 1	PRESSIONE DI ALIMENTAZIONE	COD. UGELLO Pos. 37	Ø 1/100	COD. BY-PASS Pos. 4	Ø 1/100
C Qn = 3,5 kW	G 20	AT-DK-ES-FI-IE-IT-PT-GB-SE-CH	20 mbar	0100905	145	0102060	100
		DE-BE-FR	20/25 mbar	0100905	145	0102060	100
	G 25	NL	25 mbar	0102009	146	0102062	105
		DE	20 mbar	0109072	155	0102061	110
	G 30 G 31	BE-DK-ES-FI-FR-IE IT-NL-PT-GB-SE	28-30/37 mbar	0102010	90	0102063	60
		DE-AT-CH	50 mbar	0102011	80 R	0102064	50
D Qn = 5,5 kW	G 20	AT-DK-ES-FI-IE-IT-PT-GB-SE-CH	20 mbar	0102012	180	0102061	110
		DE-BE-FR	20/25 mbar	0102012	180	0102061	110
	G 25	NL	25 mbar	0100906	185	0102066	115
		DE	20 mbar	0101020	200	0102065	120
	G 30 G 31	BE-DK-ES-FI-FR-IE IT-NL-PT-GB-SE	28-30/37 mbar	0100907	116	0102067	70
		DE-AT-CH	50 mbar	0102013	95 R	0102063	60

