

# SERIE 909

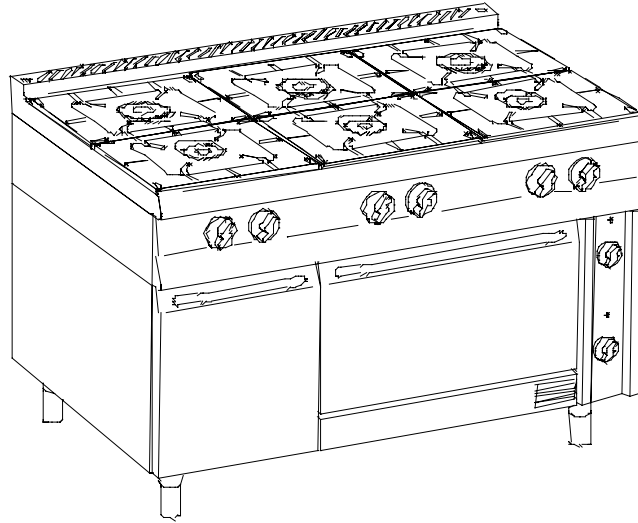

CUCINA GAS 6 FUOCHI SU FORNO ELETTRICO E VANO ARMADIATO

1 bruciatore da 3.5 Kw + 3 bruciatori da 5.5 Kw + 2 bruciatori da 7 Kw + 1 forno elettrico da 5 Kw

GAS RANGES 6 BURNERS ON ELECTRIC OVEN AND CUPBOARD

1 burner 3.5 Kw + 3 burners 5.5 Kw + 2 burners 7 kW + 1 electric oven 5 Kw

GASHERDE 6 FLAMMEN MIT ELEKTRO-BACKOFEN UND SCHRANKUNTERBAU MIT TÜR

1 x 3.5 Kw-Brenner + 3 x 5,5kW-Brenner + 2 x 7kW-Brenner + 1 elektro-Backofen 5 Kw

FORNEAUX GAZ 6 FEUX AVEC FOUR ELECTRIQUE ET ARMOIRE AVEC PORTE

1 brûleur 3.5 Kw + 3 brûleurs 5.5 Kw + 2 brûleurs 7 Kw + 1 four électrique 5 Kw

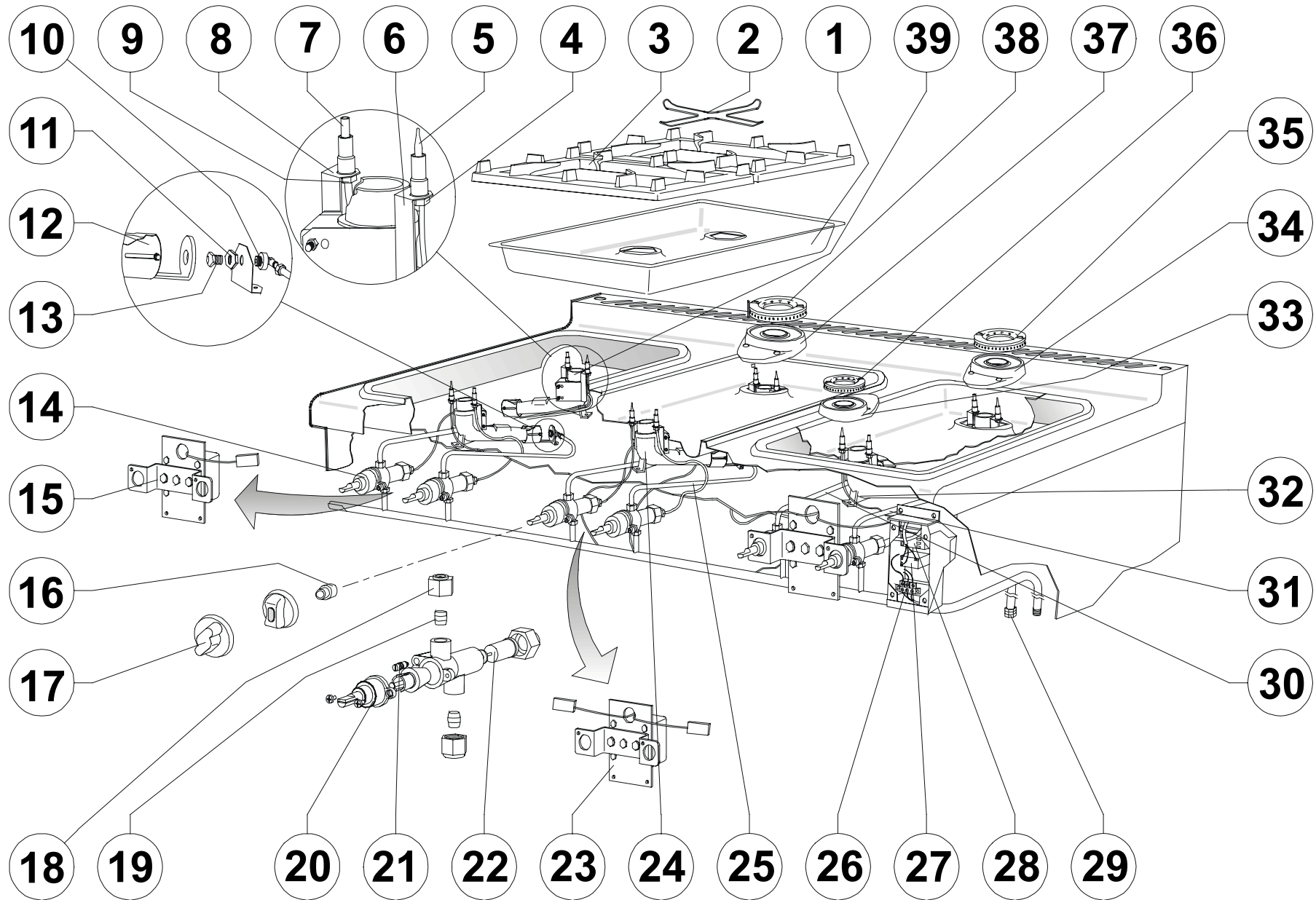

	COD.	REV.	DESCRIZIONE	DESCRIPTION	BESCHREIBUNG	DESCRIPTION
1	9203236		Bacinella piano in acciaio inox	Stainless steel top basin	Kochmulde aus Edelstahl	Plateau inox
2	0101080		Griglia riduzione	Pan support reduc. piece	Reduzierring	Grille de réduction
3	9203237	01	Griglia piano	Pan support	Auflagerost	Grille
4	0100817		Raccordo per termocoppia	Thermocouple connection	Verschraubung für Thermoelement	Raccord pour couple thermo-électrique
5	0100808	C	Termocoppia L=400 mm	Thermocouple L=400 mm	Thermoelement 400 mm lang	Couple thermo-électrique L=400 mm
5a	0100809	C	Termocoppia L=850 mm	Thermocouple L=850 mm	Thermoelement 850 mm lang	Couple thermo-électrique L=850 mm
6	LB838-00		Supporto per termocoppia	Support for thermocouple	Halterung für Thermoelement	Support couple thermo-électrique
6a	9300545		Supporto per termocoppia bruciatore E	Support for thermocouple burner E	Halterung für Thermoelement brenner E	Support couple thermo-électrique brûleur E
7	9300539	C	Candela e cavetto d'accensione L=1750 mm	Igniter plug and cable L=1750 mm	Zündkerze mit Zündkabel 1750 mm lang	Bougie et fil d'allumage L=1750 mm
7a	9300540	C	Candela e cavetto d'accensione L=1350 mm	Igniter plug and cable L=1350 mm	Zündkerze mit Zündkabel 1350 mm lang	Bougie et fil d'allumage L=1350 mm
7b	9300541	C	Candela e cavetto d'accensione L=950 mm	Igniter plug and cable L=950 mm	Zündkerze mit Zündkabel 950 mm lang	Bougie et fil d'allumage L=950 mm
7c	9300542	C	Candela e cavetto d'accensione L=550 mm	Igniter plug and cable L=550 mm	Zündkerze mit Zündkabel 550 mm lang	Bougie et fil d'allumage L=550 mm
8	LB839-00		Supporto per candela d'accensione	Support for igniter plug	Halterung für Zündkerze	Support pour bougie d'allumage
8a	9300544		Supporto per candela bruciatore E	Support for igniter plug burner E	Halterung für Zündkerze Brenner E	Support pour bougie d'allumage brûleur E
9	0100620		Raccordo per candela d'accensione	Igniter plug connection	Verschraubung für Zündkerze	Raccord pour bougie d'allumage
10	0100767		Raccordo per ugello	Nozzle junction	Düsenverbindung	Raccord gicleur
11	0100770		Dado	Nut	Mutter	Ecrou
12	0100264		Boccola aria primaria	Primary air bush	Luftschieber	Douille air primaire
13	vedi tabella		Ugello	Nozzle	Düse	Gicleur
14	0100730	C	Rubinetto per fuochi aperti	Cock for open burners	Gasarmatur für offene Kochstellenbrenner	Robinet pour brûleur ouverts
15	9300518		Gruppo accensione finale	Ignition system	Zündsystem	Systeme d'allumage
16	9201543		Prolunga per manopola gas cod. 0101786 (nera)	Extension for knob cod. 0101786 (black)	Verlängerung für Knebel cod.0101786 (schwarz)	Prolonge pour manette cod. 0101786 (noir)
17	0101786		Manopola "S" per fuochi aperti	Knob "S" for open burners	knebel "S" für offene Kochstellenbrenner	Manette "S" pour feux vifs
17a	0101953		Manopola Ø65 per fuochi aperti completa di tappo	Knob Ø65 for open burners with insert	Knebel Ø65 für offene Kochstellenbrenner mit Pfropfen	Manette Ø65 pour feux vifs avec insert
18	0100774		Raccordo per conduttura gas Ø10	Gas pipe fitting Ø10	Verschraubung für Gasleitung Ø10	Raccord pour tube gaz Ø10
19	0100775		Bicono per conduttura gas Ø10	Gas pipe bicone Ø10	Doppelkegelring für Gasleitung Ø10	Bicône pour tube gaz Ø10
20	0100753		Coperchio	Cover	Verschlusskappe	Couvercle
21	vedi tabella		By-pass	By-pass	By-pass	By-pass
22	0100752		Magnete	Magneto	Magnet	Magnéto
23	9300519		Gruppo accensione	Ignition unit	Zündungsgruppe	Groupe d'allumage
24	0100302		Venturi per bruciatore 5.5 Kw lav. per boccola	Venturi tube for burner 5.5 Kw for bush	Venturirohr für Brenner 5.5 Kw für Luftschieber	Venturi pour brûleur 5.5 Kw pour douille
25	9201536		Conduttura gas anteriore, bruciatore D	Front gas pipe burner D	Gasleitung vorne, D-Brenner	Tube gaz avant brûleur D
26	0101253		Morsettiera	Junction block	Anschlußklemme	Serre-fils
27	0101195	C	Trasformatore d'accensione per 6 fuochi	Ignition transformer for 6 burners	Zündtransformator für 6 brenner	Transformateur d'allumage pour 6 brûleur
28	0101194	C	Trasformatore d'accensione per 4 fuochi	Ignition transformer for 4 burners	Zündtransformator für 4 brenner	Transformateur d'allumage pour 4 brûleur
29	0101275		Raccordo filettato antistr. 107Z/11	Threaded connection 107Z/11	Verschraubung 107Z/11	Raccord fileté 107Z/11
30	9201535		Conduttura gas posteriore, bruciatore D-E	Rear gas pipe burner D-E	Gasleitung hinten, D, E-Brenner	Tube gaz arrière brûleur D-E
31	9201534		Conduttura gas anteriore, bruciatore C	Front gas pipe burner C	Gasleitung vorne, C-Brenner	Tube gaz avant brûleur C
32	0100301		Venturi per bruciatore 3.5 Kw lav. per boccola	Venturi tube for burner 3.5 Kw for bush	Venturirohr für Brenner 3.5 Kw für Luftschieber	Venturi pour brûleur 3.5 Kw pour douille
33	0100298		Corpo per bruciatore 3.5 Kw con boccola	Body for burner 3.5 Kw with bush	Brennerkörper 3.5 Kw mit Luftschieber	Corps pour brûleur 3.5 Kw avec douille
34	0100300		Corpo per bruciatore 7 Kw con boccola	Body for burner 7 Kw with bush	Brennerkörper 7 Kw mit Luftschieber	Corps pour brûleur 5.5 Kw avec douille

	COD.	REV.	DESCRIZIONE	DESCRIPTION	BESCHREIBUNG	DESCRIPTION
35	0100253		Spartifiamma per bruciatore E	Flame spreader for burner E	Brennerdeckel E	Chapeau pour brûleur E
36	0100252		Spartifiamma per bruciatore C	Flame-spreader for burner C	Brennerdeckel C	Chapeau pour brûleur C
37	0100299		Corpo per bruciatore 5.5 Kw con boccola	Body for burner 5.5 Kw with bush	Brennerkörper 5.5 Kw mit Luftschieber	Corps pour brûleur 5.5 Kw avec douille
38	0100251		Spartifiamma per bruciatore D	Flame-spreader for burner D	Brennerdeckel D	Chapeau pour brûleur D
39	0100303		Venturi per bruciatore 7 Kw lav. per boccola	Venturi tube for burner 7 Kw for bush	Venturirohr für Brenner 7 Kw für Luftschieber	Venturi pour brûleur 7 Kw pour douille

TIPO DI BRUCIATORE	GAS	NAZIONI EN 203 - 1	PRESSIONE DI ALIMENTAZIONE	CODICE UGELLO Pos. 13	Ø 1/100	CODICE BY-PASS Pos. 21	Ø 1/100
C Qn = 3,5 kW	G 20	DK - FR - IT - ES	18 mbar	0100905	145	0102060	100
		DE - AT - FI - IE - PT - GB	20 mbar	0100905	145	0102060	100
	G 25	BE - FR - NL	25 mbar	0102009	146	0102062	105
		DE	20 mbar	0109072	155	0102061	110
	G 30 G 31	FR - IE - GB - ES - BE DK - IT - NL - PT - FI	28-30 mbar	0102010	90	0102063	60
G 110	DE - AT	50 mbar	0102011	80 R	0102064	50	
D Qn = 5,5 kW	G 20	ES - DK - IT - SE - CH	8 mbar	0102043	270	REGOLABILE	-
		DK - FR - IT - ES	18 mbar	0102012	180	0102061	110
	G 25	DE - AT - FI - IE - PT - GB	20 mbar	0102012	180	0102061	110
		BE - FR - NL	25 mbar	0100906	185	0102066	115
	DE	20 mbar	0101020	200	0102065	120	
G 30 G 31	FR - IE - GB - ES - BE DK - IT - NL - PT - FI	28-30 mbar	0100907	116	0102067	70	
G 110	DE - AT	50 mbar	0102013	95 R	0102063	60	
E Qn = 7 kW	G 20	ES - DK - IT - SE - CH	8 mbar	0102044	350	REGOLABILE	-
		DK - FR - IT - ES	18 mbar	0101020	200	0102065	120
	G 25	DE - AT - FI - IE - PT - GB	20 mbar	0101020	200	0102065	120
		BE - FR - NL	25 mbar	0102015	207	0102069	130
	DE	20 mbar	0102014	220	0102068	135	
	G 30 G 31	FR - IE - GB - ES - BE DK - IT - NL - PT - FI	28-30 mbar	0101019	130	0102087	85
DE - AT		50 mbar	0102016	105R	0102067	66	
G 110	ES - DK - IT - SE - CH	8 mbar	0102045	420	REGOLABILE	-	



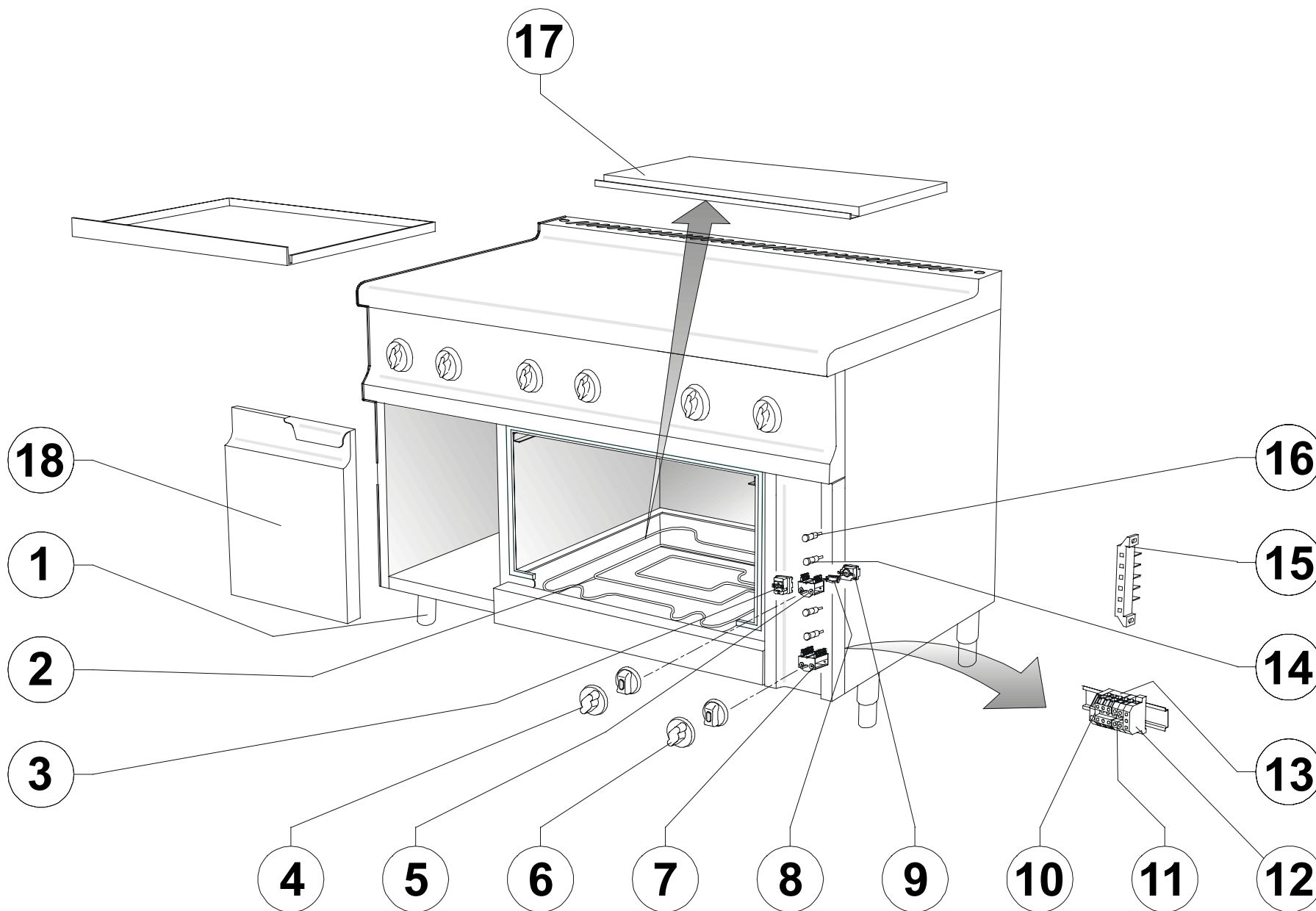

	COD.	REV.	DESCRIZIONE	DESCRIPTION	BESCHREIBUNG	DESCRIPTION
1	0100324		Assieme piedino da 2" H=165	Foot 2" H=165	Fuss 2" H=165	Pied 2" H=165
2	0101505	C	Resistenza forno 2500W 230V	Oven heating element 2500W 230V	Heizung, Backofen 2500W 230V	Résistance four 2500W 230V
3	0101375	C	Termostato di sicurezza per forno elettrico	Electric oven limit device	Temperaturbegrenzer, Backofen	Thermostat de sécurité pour le four
4	0101789		Manopola "S" per termostato 50°-310°C	Thermostatknob "S" 30°-90°C	Themostatknebel "S" 50°-310°C	Manette thermostat "S" 50°-310°C
4a	0101956		Manopola Ø 65 per termostato 50°-310°C completa di tappo	Thermostatknob Ø 65 30°-90°C with insert	Themostatknebel Ø 65 50°-310°C mit Pfropfen	Manette thermostat Ø 65 50°-310°C avec insert
5	0101379	C	Interruttore ON/OFF forno elettrico	Electric oven ON/OFF switch	EIN-AUS - Schalter, Backofen	Interrupteur ON/OFF four
6	0101788		Manopola "S" per commutatore	Knob "S" for changeover switch	Knebel "S" für Wahlschalter	Manette "S" pour commutateur
6a	0101955		Manopola Ø 65 per commutatore completa di tappo	Knob Ø 65 for changeover switch with insert	Knebel Ø 65 für Wahlschalter mit Pfropfen	Manette Ø 65 pour commutateur avec insert
7	0101398	C	Selettore resistenze del forno elettrico	Oven heating elements switch	Wahlschalter für Backofen-Heizungen	Sélecteur des résistances du four
7	0101397	01 C	Selettore resistenze del forno elettrico	Oven heating elements switch	Wahlschalter für Backofen-Heizungen	Sélecteur des résistances du four
8	0101378		Staffa EGO-617078	Bracket EGO-617078	Stütze EGO-617078	Etrier EGO-617078
9	0101384	C	Termostato di funzionamento forno elettrico	Electric oven thermostat	Betriebsthermostat, Backofen	Thermostat de fonctionnement du four
10	0101259		Morsetto terminale S8WA1808	Terminal S8WA1808	Endklemme S8WA1808	Borne terminale S8WA1808
11	0101251		Morsetto unipolare (neutro) 10111BK11	Unipolar terminal (neutral) 10111BK11	Klemme einpolig (neutral) 10111BK11	Borne unipolaire (neutre) 10111BK11
12	0101252		Morsetto unipolare (terra) 8WA1734	Unipolar terminal (earth) 8WA1734	Klemme einpolig (erde) 8WA1734	Borne unipolaire (terre) 8WA1734
13	0101260		Morsetto tripolare (fase) 8WA1304	Three-pole terminal (phase) 8WA1304	Klemme dreipolig (phase) 8WA1304	Borne tripolaire (phase) 8WA1304
14	0101167	C	Lampada spia arancione	Orange signal lamp	Kontrolleuchte orangefarbig	Voyant orange
15	0101255		Morsettiera 5F+terra FV122 V/V	Junction box	Anchlussklemme	Serre-fils
16	0101169	C	Lampada spia verde	Green signal lamp	Kontrolleuchte grün	Voyant vert
17	9203129		Suola forno elettrico	Electric oven base plate	Elektrobackofensohle	Sole du four électrique
18	9203102	02	Porta armadio	Cabinet door	Wärmeschrank tür	Porte étuve
18a	9204576	02	Porta armadio cucine versione "1"	Cabinet door version 1	Wärmeschrank Ausführung 1	Porte étuve version 1

Mod.: CCG91662

 GROUP ELECTRODOMESTIC EQUIPMENT	COD. XES30901/N	PAG. 8/9
da matricola - from serial Nr.	a matricola - to serial Nr.	

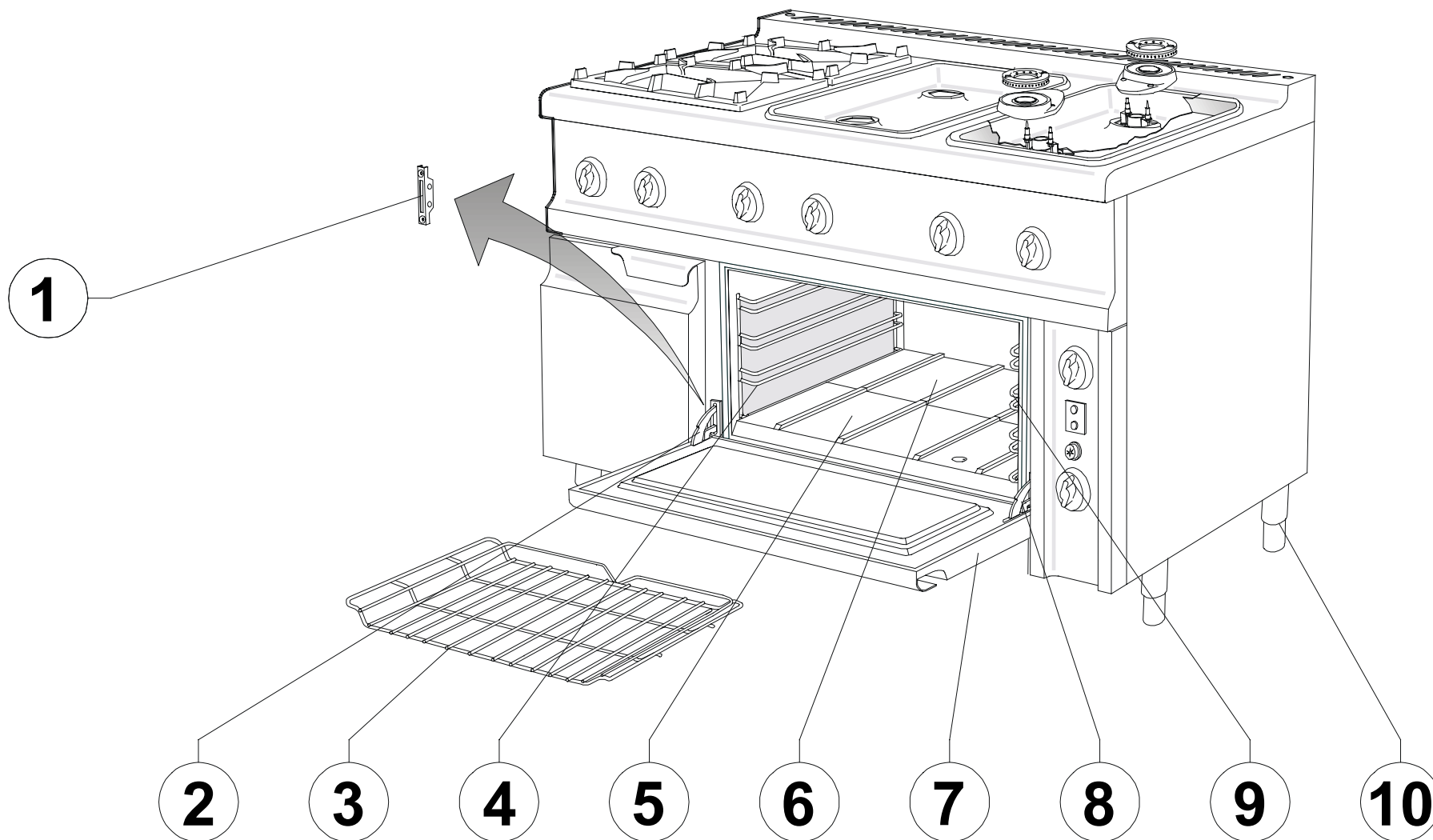

	<b>COD.</b>	<b>REV.</b>		<b>DESCRIZIONE</b>	<b>DESCRIPTION</b>	<b>BESCHREIBUNG</b>	<b>DESCRIPTION</b>
<b>1</b>	0100343		C	Fermo per cerniera	Hinge holder	Scharnierhalter	Arrêt pour charnière
<b>2</b>	0100345		C	Cerniera sx	Lh hinge	Scharnier li	Charniere gauche
<b>3</b>	9303054	05		Griglia forno	Oven grid	Backofenrost	Grille four
<b>4</b>	9303052	03		Supporto sx griglia forno	Oven lh tray slides	Rostträger li Ofenboden	Support grille gauche four
<b>5</b>	0101880			Suola forno anteriore	Oven (front) base plate	Vorderer Ofenboden	Sole antérieur four
<b>6</b>	0101879			Suola forno posteriore	Oven (rear) base plate	Hinterer Ofenboden	Sole postérieur four
<b>7</b>	9203158	04		Porta forno	Oven door	Ofentür	Porte four
<b>7a</b>	9204574	03		Porta forno cucine versione "1"	Oven door version 1	Ofentür Ausführung 1	Porte four version 1
<b>8</b>	0100346		C	Cerniera dx	Rh hinge	Scharnier re	Charniere droite
<b>9</b>	9303053	03		Supporto dx griglia forno	Oven rh tray slides	Rostträger re Ofenboden	Support grille droite four
<b>10</b>	0100324			Assieme piedino da 2" H=165	Foot 2" H=165	Fuss 2" H=165	Pied 2" H=165